



PROFESSIONAL WORKSTATION
9000 Pro

ENGLISH

DEUTSCH

FRANÇAIS

Owner's Manual
Bedienungsanleitung
Mode d'emploi



SPECIAL MESSAGE SECTION

PRODUCT SAFETY MARKINGS: Yamaha electronic products may have either labels similar to the graphics shown below or molded/stamped facsimiles of these graphics on the enclosure. The explanation of these graphics appears on this page. Please observe all cautions indicated on this page and those indicated in the safety instruction section.

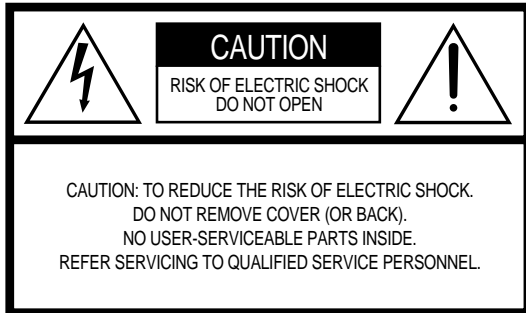

The exclamation point within the equilateral triangle is intended to alert the user to the presence of important operating and maintenance (servicing) instructions in the literature accompanying the product.

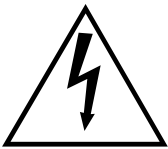

The lightning flash with arrowhead symbol, within the equilateral triangle, is intended to alert the user to the presence of uninsulated “dangerous voltage” within the product’s enclosure that may be of sufficient magnitude to constitute a risk of electrical shock.

IMPORTANT NOTICE: All Yamaha electronic products are tested and approved by an independent safety testing laboratory in order that you may be sure that when it is properly installed and used in its normal and customary manner, all foreseeable risks have been eliminated. **DO NOT** modify this unit or commission others to do so unless specifically authorized by Yamaha. Product performance and/or safety standards may be diminished. Claims filed under the expressed warranty may be denied if the unit is/has been modified. Implied warranties may also be affected.

SPECIFICATIONS SUBJECT TO CHANGE: The information contained in this manual is believed to be correct at the time of printing. However, Yamaha reserves the right to change or modify any of the specifications without notice or obligation to update existing units.

ENVIRONMENTAL ISSUES: Yamaha strives to produce products that are both user safe and environmentally friendly. We sincerely believe that our products and the production methods used to produce them, meet these goals. In keeping with both the letter and the spirit of the law, we want you to be aware of the following:

Battery Notice: This product **MAY** contain a small non-rechargeable battery which (if applicable) is soldered in place. The average life span of this type of battery is approximately five years. When replacement becomes necessary, contact a qualified service representative to perform the replacement.

Warning: Do not attempt to recharge, disassemble, or incinerate this type of battery. Keep all batteries away from children. Dispose of used batteries promptly and as regulated by applicable laws. Note: In some areas, the servicer is required by law to return the defective parts. However, you do have the option of having the servicer dispose of these parts for you.

Disposal Notice: Should this product become damaged beyond repair, or for some reason its useful life is considered to be at an end, please observe all local, state, and federal regulations that relate to the disposal of products that contain lead, batteries, plastics, etc.

NOTICE: Service charges incurred due to lack of knowledge relating to how a function or effect works (when the unit is operating as designed) are not covered by the manufacturer’s warranty, and are therefore the owners responsibility. Please study this manual carefully and consult your dealer before requesting service.

NAME PLATE LOCATION: The graphic below indicates the location of the name plate. The model number, serial number, power requirements, etc., are located on this plate. You should record the model number, serial number, and the date of purchase in the spaces provided below and retain this manual as a permanent record of your purchase.



Model _____

Serial No. _____

Purchase Date _____

IMPORTANT SAFETY INSTRUCTIONS

INFORMATION RELATING TO PERSONAL INJURY, ELECTRICAL SHOCK, AND FIRE HAZARD POSSIBILITIES HAS BEEN INCLUDED IN THIS LIST.

WARNING- When using any electrical or electronic product, basic precautions should always be followed. These precautions include, but are not limited to, the following:

- 1.** Read all Safety Instructions, Installation Instructions, Special Message Section items, and any Assembly Instructions found in this manual **BEFORE** making any connections, including connection to the main supply.
- 2.** Do not attempt to service this product beyond that described in the user-maintenance instructions. All other servicing should be referred to qualified service personnel.
- 3.** **Main Power Supply Verification:** Yamaha products are manufactured specifically for the supply voltage in the area where they are to be sold. If you should move, or if any doubt exists about the supply voltage in your area, please contact your dealer for supply voltage verification and (if applicable) instructions. The required supply voltage is printed on the name plate. For name plate location, please refer to the graphic found in the Special Message Section of this manual.
- 4. DANGER-Grounding Instructions:** This product must be grounded and therefore has been equipped with a three pin attachment plug. If this product should malfunction, the ground pin provides a path of low resistance for electrical current, reducing the risk of electrical shock. If your wall socket will not accommodate this type plug, contact an electrician to have the outlet replaced in accordance with local electrical codes. Do **NOT** modify the plug or change the plug to a different type!
- 5. WARNING:** Do not place this product or any other objects on the power cord or place it in a position where anyone could walk on, trip over, or roll anything over power or connecting cords of any kind. The use of an extension cord is not recommended! If you must use an extension cord, the minimum wire size for a 25' cord (or less) is 18 AWG. **NOTE:** The smaller the AWG number, the larger the current handling capacity. For longer extension cords, consult a local electrician.
- 6.** **Ventilation:** Electronic products, unless specifically designed for enclosed installations, should be placed in locations that do not interfere with proper ventilation. If instructions for enclosed installations are not provided, it must be assumed that unobstructed ventilation is required.
- 7.** **Temperature considerations:** Electronic products should be installed in locations that do not seriously contribute to their operating temperature. Placement of this product close to heat sources such as; radiators, heat registers etc., should be avoided.
- 8.** This product was **NOT** designed for use in wet/damp locations and should not be used near water or exposed to rain. Examples of wet /damp locations are; near a swimming pool, spa, tub, sink, or wet basement.
- 9.** This product should be used only with the components supplied or; a cart ,rack, or stand that is recommended by the manufacturer. If a cart, rack, or stand is used, please observe all safety markings and instructions that accompany the accessory product.
- 10.** The power supply cord (plug) should be disconnected from the outlet when electronic products are to be left unused for extended periods of time. Cords should also be disconnected when there is a high probability of lightning and/or electrical storm activity.
- 11.** Care should be taken that objects do not fall and liquids are not spilled into the enclosure through any openings that may exist.
- 12.** Electrical/electronic products should be serviced by a qualified service person when:
 - a. The power supply cord has been damaged; or
 - b. Objects have fallen, been inserted, or liquids have been spilled into the enclosure through openings; or
 - c. The product has been exposed to rain; or
 - d. The product does not operate, exhibits a marked change in performance; or
 - e. The product has been dropped, or the enclosure of the product has been damaged.
- 13.** This product, either alone or in combination with an amplifier and headphones or speaker/s, may be capable of producing sound levels that could cause permanent hearing loss. **DO NOT** operate for a long period of time at a high volume level or at a level that is uncomfortable. If you experience any hearing loss or ringing in the ears, you should consult an audiologist.
IMPORTANT: The louder the sound, the shorter the time period before damage occurs.
- 14.** Some Yamaha products may have benches and/or accessory mounting fixtures that are either supplied as a part of the product or as optional accessories. Some of these items are designed to be dealer assembled or installed. Please make sure that benches are stable and any optional fixtures (where applicable) are well secured **BEFORE** using. Benches supplied by Yamaha are designed for seating only. No other uses are recommended.

PLEASE KEEP THIS MANUAL

PRECAUTIONS

PLEASE READ CAREFULLY BEFORE PROCEEDING

* Please keep these precautions in a safe place for future reference.



WARNING

Always follow the basic precautions listed below to avoid the possibility of serious injury or even death from electrical shock, short-circuiting, damages, fire or other hazards. These precautions include, but are not limited to, the following:

- This instrument contains no user-serviceable parts. Do not attempt to disassemble or modify the internal components in any way.
- Do not expose the instrument to rain, use it near water or in damp or wet conditions, or place containers on it containing liquids which might spill into any openings.
- If the power cord or plug becomes frayed or damaged, or if there is a sudden loss of sound during use of the instrument, or if any unusual smells or smoke should appear to be caused by it, immediately turn off the power switch, disconnect the electric plug from the outlet, and have the instrument inspected by qualified Yamaha service personnel.
- Only use the voltage specified as correct for the instrument. The required voltage is printed on the name plate of the instrument.
- Always connect the three-pin attachment plug to a properly grounded power source. (For more information about the main power supply, see page 14.)
- Before cleaning the instrument, always remove the electric plug from the outlet. Never insert or remove an electric plug with wet hands.
- Check the electric plug periodically and remove any dirt or dust which may have accumulated on it.



CAUTION

Always follow the basic precautions listed below to avoid the possibility of physical injury to you or others, or damage to the instrument or other property. These precautions include, but are not limited to, the following:

- Do not place the power cord near heat sources such as heaters or radiators, and do not excessively bend or otherwise damage the cord, place heavy objects on it, or place it in a position where anyone could walk on, trip over, or roll anything over it.
- When removing the electric plug from the instrument or an outlet, always hold the plug itself and not the cord. Pulling by the cord can damage it.
- Do not connect the instrument to an electrical outlet using a multiple-connector. Doing so can result in lower sound quality, or possibly cause overheating in the outlet.
- Remove the electric plug from the outlet when the instrument is not to be used for extended periods of time, or during electrical storms.
- Before connecting the instrument to other electronic components, turn off the power for all components. Before turning the power on or off for all components, set all volume levels to minimum. Also, be sure to set the volumes of all components at their minimum levels and gradually raise the volume controls while playing the instrument to set the desired listening level.
- Do not expose the instrument to excessive dust or vibrations, or extreme cold or heat (such as in direct sunlight, near a heater, or in a car during the day) to prevent the possibility of panel disfiguration or damage to the internal components.
- Do not use the instrument near other electrical products such as televisions, radios, or speakers, since this might cause interference which can affect proper operation of the other products.
- Do not place the instrument in an unstable position where it might accidentally fall over.
- Before moving the instrument, remove all connected cables.
- When cleaning the instrument, use a soft, dry cloth. Do not use paint thinners, solvents, cleaning fluids, or chemical-impregnated wiping cloths. Also, do not place vinyl, plastic or rubber objects on the instrument, since this might discolor the panel or keyboard.
- Do not rest your weight on, or place heavy objects on the instrument, and do not use excessive force on the buttons, switches or connectors.
- Do not place objects in front of the instrument's air vent, since this may prevent adequate ventilation of the internal components, and possibly result in the instrument overheating.
- Do not operate the instrument for a long period of time at a high or uncomfortable volume level, since this can cause permanent hearing loss. If you experience any hearing loss or ringing in the ears, consult a physician.

■ SAVING USER DATA

- Always save data to a floppy disk frequently, in order to help prevent the loss of important data due to a malfunction or user operating error.

Yamaha cannot be held responsible for damage caused by improper use or modifications to the instrument, or data that is lost or destroyed.

Always turn the power off when the instrument is not in use.

Using the Floppy Disk Drive (FDD) and Floppy Disks

Be sure to handle floppy disks and treat the disk drive with care. Follow the important precautions below.

Compatible Disk Type

3.5" 2DD and 2HD type floppy disks can be used.

Inserting/Ejecting Floppy Disks

- To insert a floppy disk into the disk drive:
 - Hold the disk so that the label of the disk is facing upward and the sliding shutter is facing forward, towards the disk slot. Carefully insert the disk into the slot, slowly pushing it all the way in until it clicks into place and the eject button pops out.

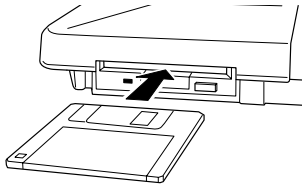

NOTE

- When the 9000Pro is turned on, the LED below the floppy disk slot will be lit indicating that the Disk Drive is ready to use.

- To eject a floppy disk:
 - Before ejecting the disk, be sure to confirm that the FDD is stopped (check if the DISK IN USE lamp is off). Press the eject button slowly as far as it will go; the disk will automatically pop out. When the disk is fully ejected, carefully remove it by hand.

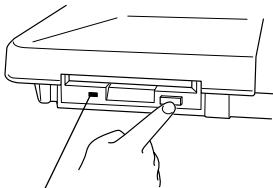

This lamp is always on when the power is on, regardless of the disk operation.

DISK IN USE

This lamp lights during disk read/write operations, such as when a disk has been inserted, during recording, playback, formatting, etc.



DISK IN USE

MASTER VOLUME

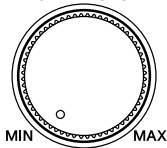

- If the eject button is pressed too quickly, or if it is not pressed in as far as it will go, the disk may not eject properly. The eject button may become stuck in a half-pressed position with the disk extending from the drive slot by only a few millimeters. If this happens, do not attempt to pull out the partially ejected disk, since using force in this situation can damage the disk drive mechanism or the floppy disk. To remove a partially ejected disk, try pressing the eject button once again, or push the disk back into the slot and then repeat the eject procedure.

- Never attempt to remove the disk or turn the power off during recording, reading and playing back. Doing so can damage the disk and possibly the disk drive.
- Be sure to remove the floppy disk from the disk drive before turning off the power. A floppy disk left in the drive for extended periods can easily pick up dust and dirt that can cause data read and write errors.

Cleaning the Disk Drive Read/Write Head

- Clean the read/write head regularly. This instrument employs a precision magnetic read/write head which, after an extended period of use, will pick up a layer of magnetic particles from the disks used that will eventually cause read and write errors.
- To maintain the disk drive in optimum working order Yamaha recommends that you use a commercially-available dry-type head cleaning disk to clean the head about once a month. Ask your Yamaha dealer about the availability of proper head-cleaning disks.
- Never insert anything but floppy disks into the disk drive. Other objects may cause damage to the disk drive or floppy disks.

About the Floppy Disks

- To handle floppy disks with care:
 - Do not place heavy objects on a disk or bend or apply pressure to the disk in any way. Always keep floppy disks in their protective cases when they are not in use.
 - Do not expose the disk to direct sunlight, extremely high or low temperatures, or excessive humidity, dust or liquids.
 - Do not open the sliding shutter and touch the exposed surface of the floppy disk inside.
 - Do not expose the disk to magnetic fields, such as those produced by televisions, speakers, motors, etc., since magnetic fields can partially or completely erase data on the disk, rendering it unreadable.
 - Never use a floppy disk with a deformed shutter or housing.
 - Do not attach anything other than the provided labels to a floppy disk. Also make sure that labels are attached in the proper location.
- To protect your data (write-protect tab):
 - To prevent accidental erasure of important data, slide the disk's write-protect tab to the "protect" position (tab open).

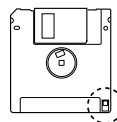

Write protect tab ON (locked or write protected)

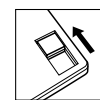
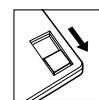

Write protect tab OFF (unlocked or write enabled)

- Data backup
 - For maximum data security Yamaha recommends that you keep two copies of important data on separate floppy disks. This gives you a backup if one disk is lost or damaged.

Congratulations!

You are the proud owner of an extraordinary electronic keyboard. The Yamaha 9000Pro combines advanced tone generation technology with state-of-the-art digital electronics and features to give you stunning sound quality with maximum musical versatility. The advanced Auto Accompaniment, Vocal Harmony, and Sampler features, in particular, are brilliant examples of how Yamaha technology can significantly expand your musical horizons. A large-size graphic display and easy-to-use interface also greatly enhance the operability of this advanced instrument. In addition, the 9000Pro lets you add optional Plug-in Boards, giving you access to an exciting and wide array of various synthesizer voices — plus the ability to edit those voices and create your own original sounds.

In order to make the most of your 9000Pro's features and vast performance potential, we urge you to read the manual thoroughly while trying out the various features described. Keep the manual in a safe place for later reference.

Packing List

Your 9000Pro includes the following items:

- **9000Pro x 1**
- **AC Power Cord x 1** page 14
- **Music Stand x 1** page 14
- **Floppy Disk (Disk Styles and MIDI Driver) x 1** page 25
- **Floppy Disks (Factory Data Backup Disk No.1/2) x 2** page 54
These include the following factory-set data: One Touch Setting, Registration Memory, Music Database, Multi Pad, Flash Style and Setup.
- **Floppy Disk (Plug-in Custom Voice Disk) x 1** page 42
This includes the voice files for Plug-in Boards
- **Owner's Manual**

Unauthorized copying of copyrighted software for purposes other than the purchaser's personal use is prohibited.

This product (9000Pro) is manufactured under license of U.S. Patents No.5231671, No.5301259, No.5428708, and No.5567901 of IVL Technologies Ltd.

Trademarks:

- Apple and Macintosh are trademarks of Apple Computer, Inc., registered in the U.S. and other countries.
- IBM-PC/AT is a trademark of International Business Machines Corporation.
- Windows is the registered trademark of Microsoft © Corporation.
- All other trademarks are the property of their respective holders.

Panel logos

The logos printed on the 9000Pro panel indicate the standards/formats it supports and special features it includes.



GM System Level 1

GM System Level 1 is an addition to the MIDI standard which guarantees that any data conforming to the standard will play accurately on any GM-compatible tone generator or synthesizer from any manufacturer.



XG

XG is a new Yamaha MIDI specification which significantly expands and improves on the GM System Level 1 standard with greater voice handling capacity, expressive control, and effect capability while retaining full compatibility with GM. By using the 9000Pro's XG voices, it is possible to record XG-compatible song files.



XF

The Yamaha XF format enhances the SMF (Standard MIDI File) standard with greater functionality and open-ended expandability for the future. The 9000Pro is capable of displaying lyrics when an XF file containing lyric data is played.



Vocal Harmony

Vocal Harmony employs state-of-the-art digital signal processing technology to automatically add appropriate vocal harmony to a lead vocal line sung by the user. Vocal Harmony can even change the character and gender of the lead voice as well as the added voices to produce a wide range of vocal harmony effects.

How to use the manual

Starting Up.....page 14

Before going on to any other part of the manual, we strongly suggest you read this section first. It shows you how to get started playing and using your new 9000Pro.

Top Panel & Connections.....page 10

Rear Panel & Connections.....page 12

Use this section to find out about all of the buttons and controls of the 9000Pro.

Contents.....page 8

All topics, features, functions, and operations are listed here in the order they appear in the manual, for easy reference.

Quick Guide..... page 16

Unless you enjoy reading manuals, you're probably eager to start playing your new 9000Pro right now. If so, read this section.

Basic Operations.....page 44

This section introduces you to the basic operating conventions of the 9000Pro, such as editing values and changing settings, and shows you how to use the convenient Direct Access functions.

Function Tree.....page 50

This lists all functions of the 9000Pro according to their hierarchical structure, letting you easily see the relationship of the various functions and quickly locate desired information.

Reference.....page 56

Once you're familiar with everything above, lightly go over this comprehensive guide to all functions. You won't need (or want) to read everything at once, but it is there for you to refer to when you need information about a certain feature or function.

Installing Optional Hardware.....page 180

This section provides detailed instructions for installing each of the 9000Pro's supported options (SIMM, Hard disk unit, and Plug-in Boards).

Appendix.....page 192

This contains various important lists such as the Voice List, Preset Style List, Effect List, MIDI Data Format, and MIDI Implementation Chart.

Troubleshooting.....page 188

If the 9000Pro does not function as expected or you have some problem with the sound or operation, consult this section before calling your Yamaha dealer or service center. Most common problems and their solutions are covered here in a very simple and easy-to-understand way.

Index.....page 190

This section alphabetically lists virtually all topics, features, functions, and operations with their respective page numbers, letting you quickly and easily find the information you need.



DOC

The DOC voice allocation format provides data playback compatibility with a wide range of Yamaha instruments and MIDI devices, including the Clavinova series.



Style File Format

The Style File Format — SFF — is Yamaha's original style file format which uses a unique conversion system to provide high-quality automatic accompaniment based on a wide range of chord types. The 9000Pro uses the SFF internally, reads optional SFF style disks, and creates SFF styles using the Style Creator function.



Plug for XG

This system offers powerful expansion and upgrade capabilities for XG-Plug-in-compatible tone generators. The XG Plug-in System enables you to equip the 9000Pro with the latest and most sophisticated technology, ensuring that you keep pace with the rapid and multi-faceted advances in modern music production.

Contents

Packing List.....	6
Panel logos	6
How to use the manual	7
Contents	8
Top Panel & Connections.....	10
Music stand.....	10
Rear Panel & Connections	12
Starting Up	14
Lamp.....	15

Quick Guide

Playing Voices	16
Playing a Voice.....	16
Playing Two or Three Voices Simultaneously	17
Playing Different Voices with the Left and Right Hands	18
Adjusting the Octave setting	18
Organ Flutes	19
Auto Accompaniment.....	20
Using Auto Accompaniment.....	20
Accompaniment Sections	22
One Touch Setting.....	24
Track Muting & Volume Control	24
Disk Direct Function.....	25
Music Database.....	26
Using the Music Database	26
Searching the Music Database	27
Registration Memory	28
Using the Preset Registration Memory	28
Registering the Panel Settings.....	29
Disk Song Playback.....	30
Playback of Song Disks	30
Vocal Harmony	32
Setting Up	32
Vocal Harmony with Accompaniment Playback.....	32
Vocal Harmony with Song Playback	33
The Multi Pads.....	34
Playing the Multi Pads.....	34
Chord Match	34
Voice Effects.....	35
Applying the Voice Effects	35
Song Creator	36
Quick Recording.....	36
Multi Track Recording.....	38
Sampling.....	40
Recording a Sample	40
Using the Optional Plug-in Board	42
Playing a Plug-in Voice.....	42

Basic Operation

Display-based Controls.....	44
Display Messages	45
Name Entry	46
Computer Keyboard Functions.....	46
Direct Access	48
Function Tree.....	50
Memory Structure	54

Reference

Demonstration	56
Voices	57
Parts: Right1, Right2, Right3 and Left.....	57
Voices.....	58
PITCH BEND Wheel & MODULATION Wheel....	59
Voice Effects.....	60
Other Keyboard-related Functions	61
Organ Flutes.....	62
Plug-in Voices.....	64
Plug-in Manager.....	66
Auto Accompaniment.....	70
Chord Fingerings.....	70
Fade-ins and Fade-outs	72
Tempo Control.....	72
Synchro Stop.....	73
One Touch Setting.....	73
Style Manager	74
Music Database	76
Creating the Music Database.....	76
The Multi Pads	77
Turning Chord Match and Repeat On/Off.....	77
Disk Song Playback.....	78
Selecting a Song.....	78
Other Functions: Viewing the Lyrics and Fast Forward/Reverse	79
Song Setup	79
Vocal Harmony	80
Applying the Vocal Harmony Effect	80
Selecting/Producing the Vocal Harmony effect .	81
Changing the Vocal Harmony/Microphone Settings.....	82
Sampling	84
Recording a Sample.....	86
Importing Wave Files from Disk	87
Clearing Wave Data	87
Editing Wave data	88
Custom Voice Creating.....	92
Easy Editing	93
Full Editing	94

Creating Plug-in Custom Voices..... 100
 Voice Editing102
 Native System Parameter Editing105
 Voice Editing on a Computer.....106
 Board Custom Voice Backup.....108
Song Creator 110
 Track Setting for Recording
 (Multi Track Recording)112
 Track Setting for Recording
 (Quick Recording)113
 Song Edit Functions (Multi Track Recording).....114
 Song Setup (Multi Track Recording).....115
 Step Recording (Multi Track Recording).....116
 Chord Step (Quick Recording)122
Style Creator 126
 Style Assembly — Creating a Style129
 Revoice (Easy Edit).....130
 Groove & Dynamics (Easy Edit).....131
 Style Recording (Full Edit)132
 Style Editing (Full Edit).....134
 Custom Style Recording via an External
 Sequence Recorder138
 Step Recording (Full Edit)140
Multi Pad Creator 141
 Multi Pad Recording.....142
 Clear142
 Copy.....142
 Turning Chord Match and Repeat On/Off142
 Step Recording143
Mixing Console 144
 Part Settings144
 Effect Type Settings.....146
 Master Equalizer Settings147
 Line Out Settings148
Disk/SCSI Operations 150
 Loading Data from a Disk to Flash ROM152
 Saving Data from Flash ROM to a Disk153
 Copying Files & Copying Floppy Disks154
 Backing Up/Restoring the Data in Flash ROM ..154
 Converting files155
 Renaming/deleting Disk Files155
 Renaming/deleting/creating Directories156
 Formatting a Disk.....156
 Checking a Disk157
The 9000Pro “Functions” 158
 Master Tuning/Scale Tuning158
 Split Point/Chord Fingering159
 Controller Assignment.....159
 Registration/Freeze Group/Voice Set Settings ..163
 Harmony/Echo Settings164
 Video Monitor Settings.....165
 Talk Setting165
 Utility Settings166

MIDI Functions 168
 System Settings 175
 Transmit Settings..... 175
 Receive Settings 176
 Root Settings..... 177
 Chord Detect Settings 177
 Storing the MIDI Settings 177
 MFC10 Settings 178
Installing Optional Hardware 180
 Optional Plug-in Board Installation..... 181
 Optional Hard Disk Installation..... 184
 Optional SIMM Installation 185
Troubleshooting..... 188
Index 190

Appendix

Voice List..... 192
 Keyboard Drum Assignments..... 200
 Plug-in Voice List..... 204
 Style List..... 212
 Multi Pad Bank List..... 213
 Parameter Chart..... 214
 Effect Type List 220
 Effect Parameter List..... 222
 Effect Data Value Assign Table..... 227
 MIDI Data Format..... 228
 MIDI Implementation Chart 244
 Specifications 246

Top Panel & Connections

PHONES jack... page 13

Music stand
The 9000Pro is supplied with a music stand that can be attached to the instrument by inserting it into the holes as shown.

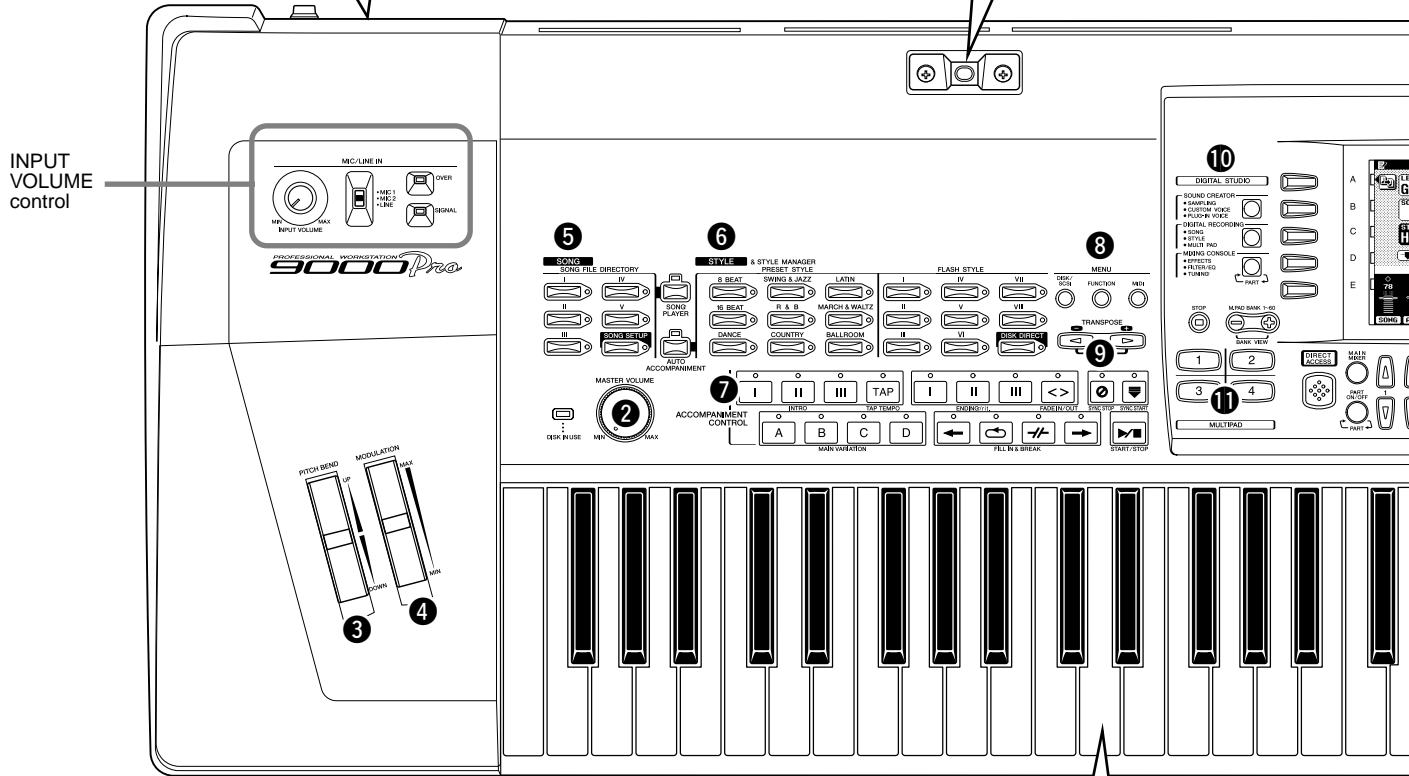

Floppy Disk Drive... page 25, 30, 150
The 9000Pro also features a built-in disk drive that lets you save all your important original data to floppy disk for future recall. The 9000Pro is compatible with a wide variety of disk formats, allowing you to playback song data on commercially available XG, GM, DOC, and Disklavier Piano Soft disks.

Keyboard... page 162
The keyboard of the 9000Pro is equipped with a touch response feature (initial touch and after touch) that lets you dynamically and expressively control the level of the voices with your playing strength — just as on an acoustic instrument.

1 POWER ON/OFF switch.....	14	7 ACCOMPANIMENT CONTROL buttons	20
2 MASTER VOLUME control.....	14	8 MENU buttons.....	150, 158, 174
3 PITCH BEND wheel	59	9 TRANSPOSE buttons.....	61
4 MODULATION wheel.....	59	10 DIGITAL STUDIO buttons.....	36, 40, 84, 92, 100, 110, 126, 141
5 SONG buttons	30, 78	11 MULTI PAD buttons.....	34, 77, 141
6 STYLE buttons	20		

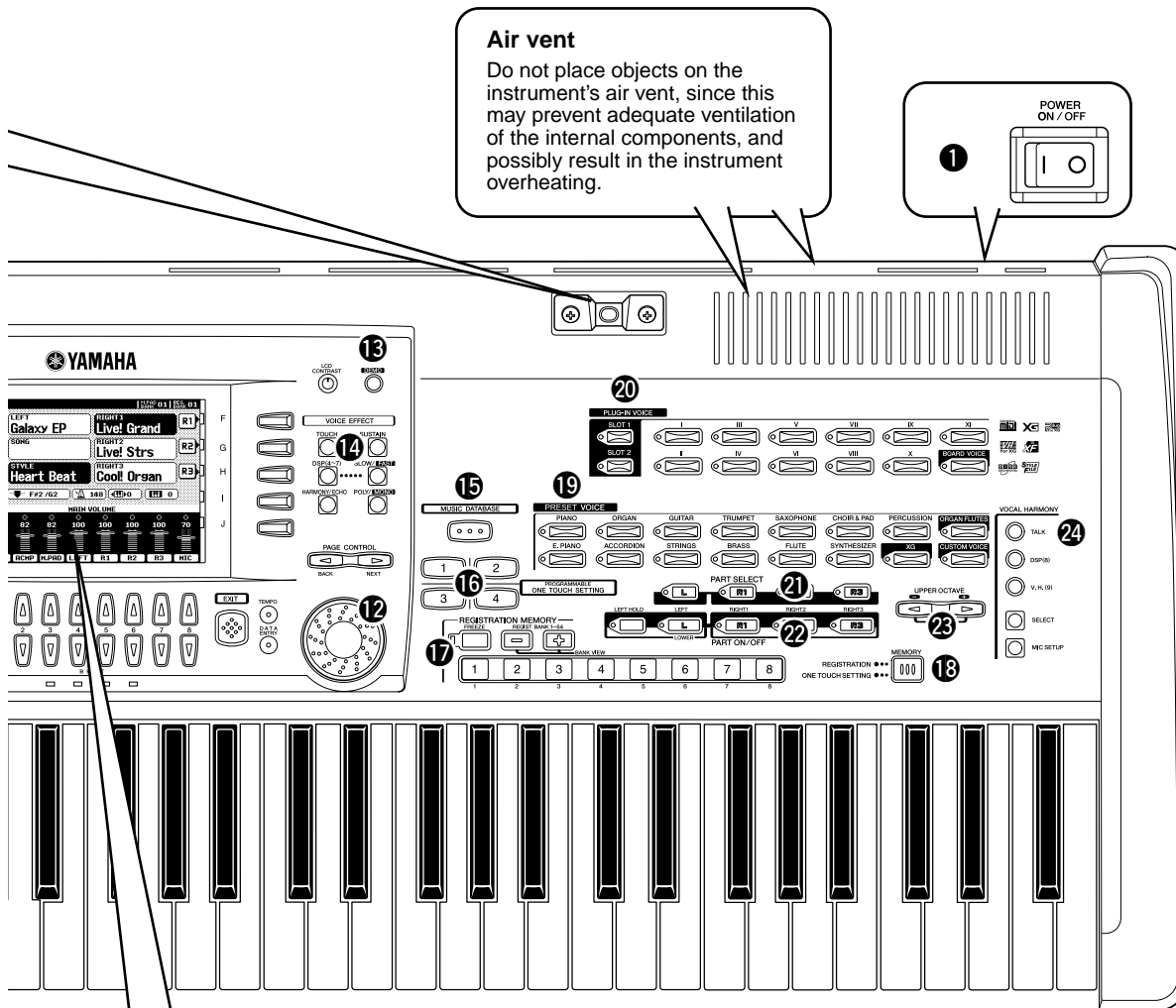

Air vent
Do not place objects on the instrument's air vent, since this may prevent adequate ventilation of the internal components, and possibly result in the instrument overheating.

1
POWER ON / OFF

Liquid Crystal Display (LCD) and Related Buttons/Controls
... page 44

Large multi-function LCD display panel with display-based buttons, plus comprehensive display prompts and messages, makes operation easy and intuitive.

- Related Buttons/Controls :
- LCD(A-J) buttons
 - LCD(1-8) buttons
 - DIRECT ACCESS button
 - MAIN MIXER button
 - PART ON/OFF button
 - EXIT button
 - PAGE CONTROL buttons
 - LCD CONTRAST control

The illustrations and LCD screens as shown in this owner's manual are for instructional purposes only, and may be different from your instrument.

12 Data dial.....	44	18 MEMORY button	28, 73
13 DEMO button	56	19 VOICE buttons.....	16, 58
14 VOICE EFFECT buttons	35, 60	20 PLUG-IN VOICE buttons.....	42, 58
15 MUSIC DATABASE button	26, 76	21 PART SELECT buttons	57
16 ONE TOUCH SETTING button	24, 73	22 PART ON/OFF buttons.....	17, 18, 57
17 REGISTRATION MEMORY buttons	28	23 UPPER OCTAVE buttons	18
		24 VOCAL HARMONY buttons.....	32, 80

Rear Panel & Connections

CAUTION

- Make sure that the POWER switch is in the OFF (extended) position before making any connections. If you make connections while the POWER switch is on, you risk damaging external equipment such as the amp or speakers.

An optional lamp can be connected to the 9000Pro. This is especially convenient when using the 9000Pro in situations of low available light. See page 15 for details.

The TRIM control allows the input sensitivity of the AUX IN L/L+R and R (LOOP RETURN) jacks to be adjusted for optimum level matching with the connected equipment.

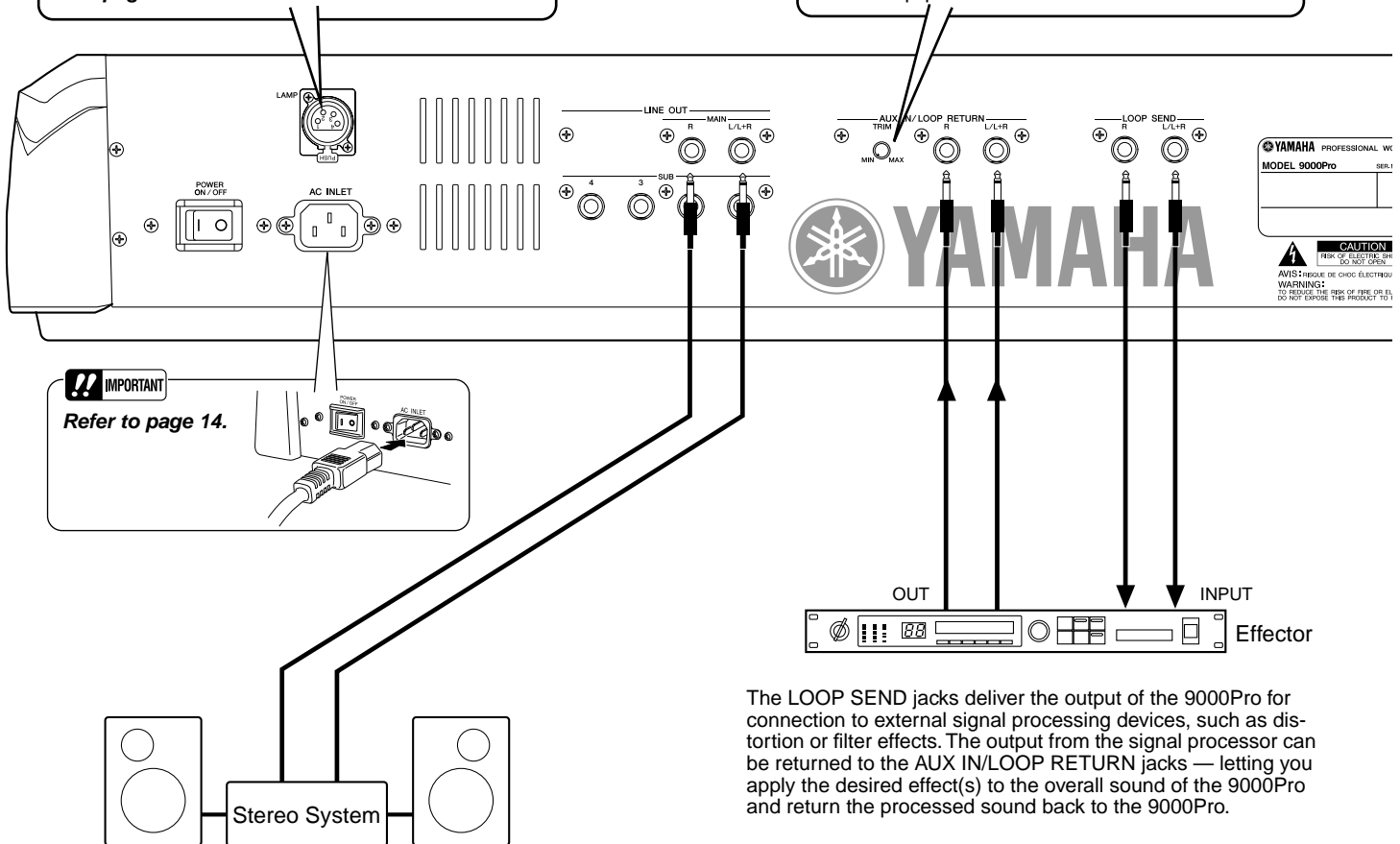

!! IMPORTANT
Refer to page 14.

The LOOP SEND jacks deliver the output of the 9000Pro for connection to external signal processing devices, such as distortion or filter effects. The output from the signal processor can be returned to the AUX IN/LOOP RETURN jacks — letting you apply the desired effect(s) to the overall sound of the 9000Pro and return the processed sound back to the 9000Pro.

The LINE OUT jacks are used to send the 9000Pro output to a keyboard amplifier, stereo sound system, mixing console, or tape recorder. If you are connecting the 9000Pro to a mono sound system, use only the L/L+R jack. When only this jack is connected (using a standard phone plug), the left and right channels are combined and output through this jack — allowing you have a mono mix of the 9000Pro's stereo sound.

Refer to page 148.

!! IMPORTANT

- Since the 9000Pro has no built-in speakers, you need to monitor its sound output via external audio equipment. Alternatively, you could use a pair of headphones.

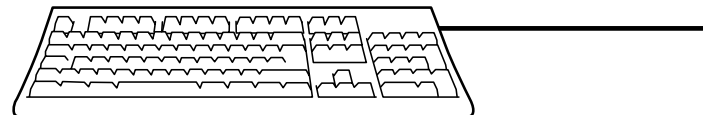

You can connect a computer keyboard to the 9000Pro for inputting song and file names or Voice/Style/Song/Registration Memory numbers. This function is also very convenient in Step recording. Please note that Macintosh computer keyboards cannot be used with the 9000Pro. Refer to pages 46, 167.

NOTE

- A computer keyboard can only be used if it has been connected to the 9000Pro before turning the power on. If you have connected a computer keyboard after turning the power on, simply turn the power off and back on again.

PHONES jack

A standard pair of stereo headphones can be plugged in here for private practice or late-night playing. Use the [MASTER VOLUME] control to adjust the volume of the headphone sound.

MIC/LINE IN jack

The 9000Pro includes a microphone/line input jack which is compatible with virtually any standard microphone or line-level source, accepting either 1/4" phone plugs or XLR connectors. The microphone or line input can be used with the 9000Pro's vocal harmony function.

! IMPORTANT

- The MIC/LINE jacks can be used with either 1/4" phone plugs or XLR connectors; however, they are special differential input connectors. For phone plugs, the tip and ring of the plug correspond to "+" and "-", respectively. Because of this arrangement, connecting a stereo signal (such as from a CD player) with a stereo phone jack to the 9000Pro results in the left and right signals cancelling each other out. To properly connect a CD player or other stereo source, make sure to use a mono input, either left or right, or a mix of the stereo signal (pages 32, 80).

An optional lamp can be connected to the 9000Pro. This is especially convenient when using the 9000Pro in situations of low available light. See page 15 for details.

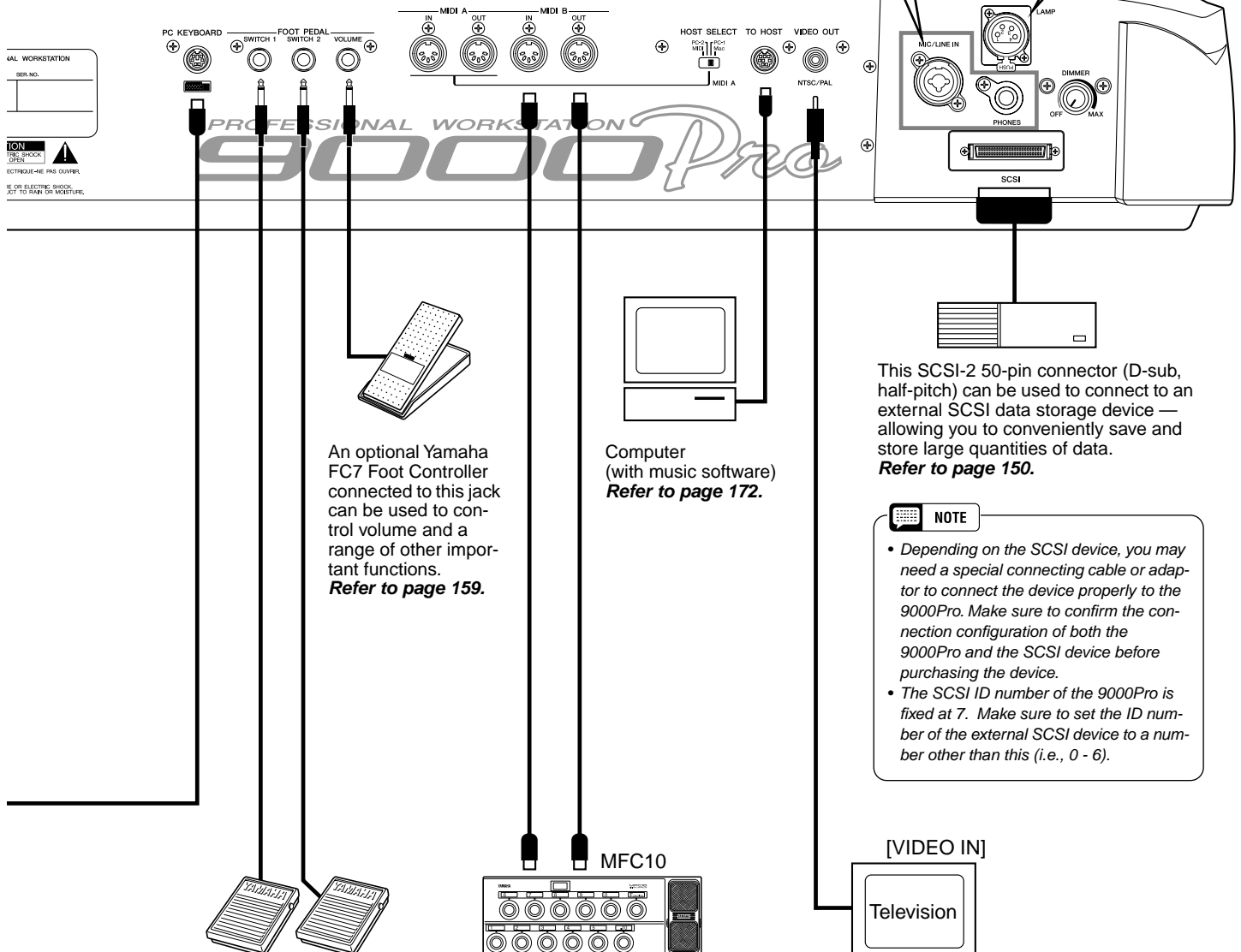

GENERAL WORKSTATION
SER. NO.
CAUTION: THE BATTERY COVER IS UNDER THE BATTERY COVER. DO NOT REMOVE THE BATTERY COVER.
IF OR ELECTRIC SHOCK, CONTACT YOUR LOCAL SERVICE CENTER.

An optional Yamaha FC7 Foot Controller connected to this jack can be used to control volume and a range of other important functions. Refer to page 159.

Computer (with music software) Refer to page 172.

This SCSI-2 50-pin connector (D-sub, half-pitch) can be used to connect to an external SCSI data storage device — allowing you to conveniently save and store large quantities of data. Refer to page 150.

NOTE

- Depending on the SCSI device, you may need a special connecting cable or adaptor to connect the device properly to the 9000Pro. Make sure to confirm the connection configuration of both the 9000Pro and the SCSI device before purchasing the device.
- The SCSI ID number of the 9000Pro is fixed at 7. Make sure to set the ID number of the external SCSI device to a number other than this (i.e., 0 - 6).

One or two optional Yamaha FC5 foot-switches connected to these jacks can be used to control sustain and a range of other important functions. Refer to page 160.

The sophisticated MIDI functions give you powerful tools to expand your music performance and creation possibilities. Refer to page 168.

[VIDEO IN]

You can connect the 9000Pro to a television or video monitor to display the lyrics and chords in your song data on a larger screen. Refer to page 165.

! IMPORTANT

- The 9000Pro's default setting for the external television/video monitor signal is "PAL." Depending on your particular locale, the standard may be different and the setting should be changed accordingly. (For example, NTSC is generally used in North America.) Check the standard used by your television or video monitor, and if it is not PAL, change the setting in the VIDEO OUT display to "NTSC" (page 165).

Starting Up

Use the following procedure to start up the 9000Pro.

➤ **1** Make sure that the **POWER** switch is in the **OFF** position.

➤ **2** Securely plug the “female” end of the AC power cord supplied with the 9000Pro into the rear-panel AC cord socket.

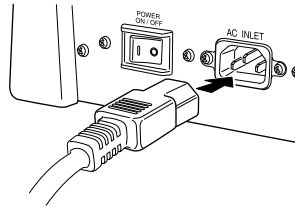

➤ **3** Plug the power cord into a convenient AC outlet.

To disconnect the AC power cord, set the POWER switch to OFF, then unplug the AC power cord from the AC outlet, and disconnect it from the 9000Pro AC INLET.

➤ **4** Make all necessary connections (pages 12 and 13), making sure first that all level controls on those devices are set to the minimum. (Refer to the owner’s manuals of the devices you are using for more information on connections.)

Since the 9000Pro has no built-in speakers, you need to monitor its sound output via external audio equipment. Alternatively, you could use a pair of headphones.

➤ **5** Turn the power ON. If you’ve connected any external devices to the 9000Pro, turn on the power of those devices in the following order:

⚠ WARNING

- Make sure your 9000Pro is rated for the AC voltage supplied in the area in which it is to be used (as listed on the rear panel). Connecting the unit to the wrong AC supply can cause serious damage to the internal circuitry and may even pose a shock hazard!
- Use only the AC power cord supplied with the 9000Pro. If the supplied cord is lost or damaged and needs to be replaced, contact your Yamaha dealer. The use of an inappropriate replacement can pose a fire and shock hazard!
- The type of AC power cord provided with the 9000Pro may be different depending on the country in which it is purchased (a third prong may be provided for grounding purposes). Improper connection of the grounding conductor can create the risk of electrical shock. Do NOT modify the plug provided with the 9000Pro. If the plug will not fit the outlet, have a proper outlet installed by a qualified electrician. Do not use a plug adapter which defeats the grounding conductor.

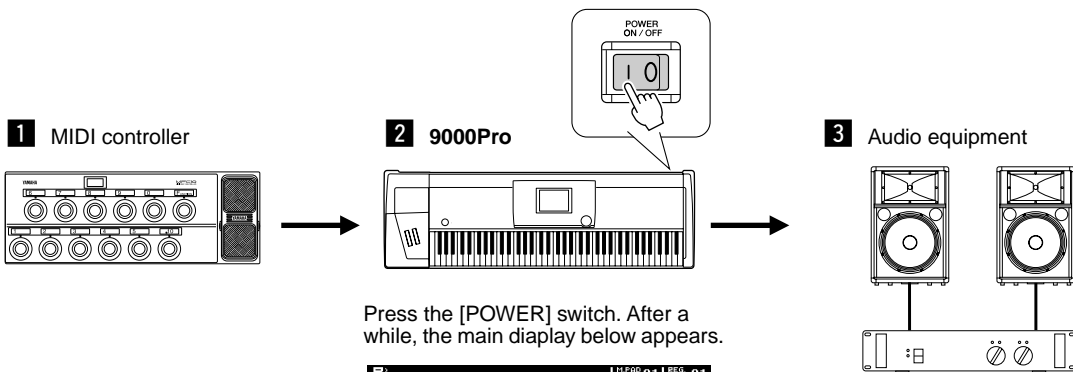

When turning off the power, make sure that all level controls on those devices above are set to the minimum and simply reverse the above order.

➤ **6** Turn up the volume of the external audio equipment, as necessary.

➤ **7** After the main display appears, play and adjust the volume.



Lamp

The 9000Pro features two Lamp terminals (at either end of the rear panel) for connecting an optional lamp. This is especially convenient when using the 9000Pro in situations of low available light. To turn on the lamp, use the switch/dimmer control at the left end of the rear panel (as viewed from the keyboard side).

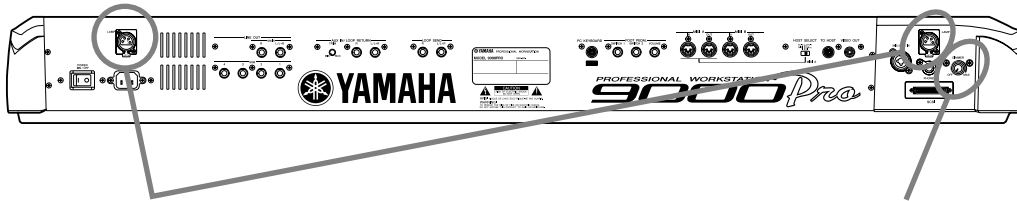

Either or both terminals can be used, letting you connect up to two lamps.

Use this to turn the lamp on and off and control the brightness.

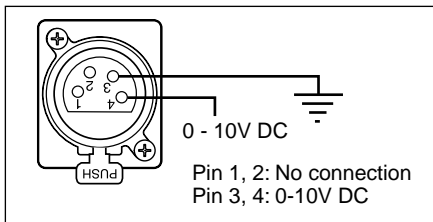

⚠ WARNING

To avoid possible damage to the instrument, follow these precautions:

- Only use lamps that conform to the specifications listed at left.
- Do not attempt to insert anything other than a proper lamp to the Lamp terminals.
- Do not short-circuit the terminals.
- Do not apply electrical voltage (power) to the Lamp terminals.

⚠ WARNING

- Make sure the gooseneck of the lamp is 12 inches or shorter. Goosenecks of longer lengths may be unstable.
- The connected lamp becomes very hot after being on for a while. Make sure you let the lamp cool before trying to touch it.

Only use lamps conforming to the following specifications:

- Lamp: 12V 5W
- Connector: 4-pin XLR

- ▶ **1** Make sure that the **POWER** switch is off.
- ▶ **2** Connect a lamp to one of the terminals on the rear panel. Firmly push the lamp connector into the socket until it locks.
- ▶ **3** Turn the power on by pressing the **[POWER]** switch.
- ▶ **4** Use the **[DIMMER]** control to turn the lamp on.

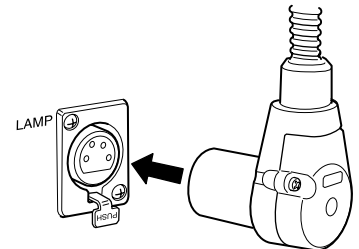

NOTE

- The light bulb will burn out over a long period of use. When this happens, replace the bulb with a new one. You can extend the life of the bulb by turning the **[DIMMER]** control down toward **[MIN]** when using the lamp.

To disconnect the lamp:

First, make sure the lamp is off (the **[DIMMER]** is set to **OFF**), then unplug the lamp while holding down the **PUSH** latch on the rear panel.

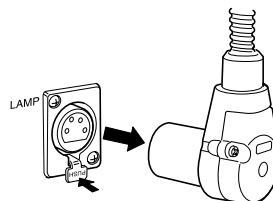

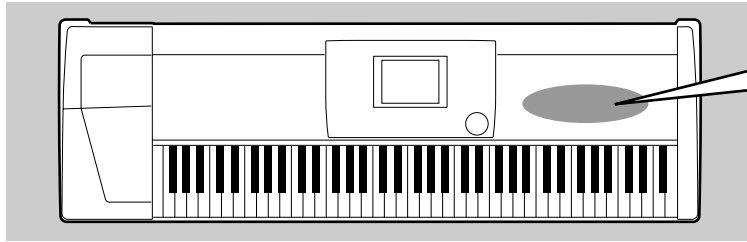

Voice related buttons

Playing a Voice

- **1** Press the [R1] LCD button to turn the RIGHT1 part on.

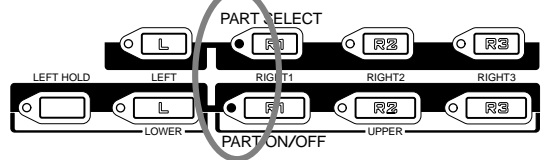
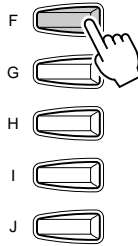
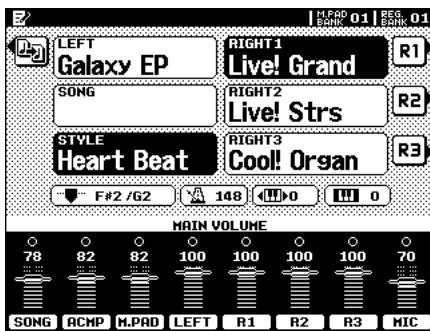

NOTE

• The voice selected here is called voice RIGHT 1. See page 57 for more information on voice RIGHT1.

- **2** Select a voice group.

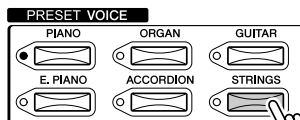

For this example, STRINGS is selected.

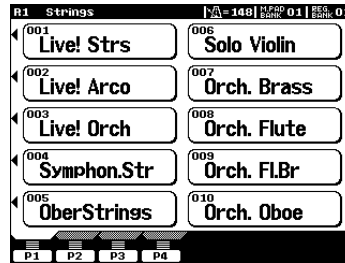

- **3** Select a voice.



For this example, Live! Orch is selected.

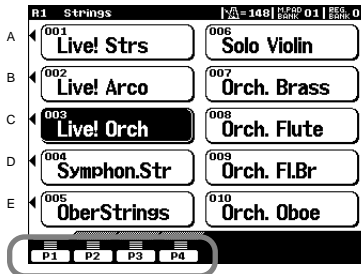

Press the corresponding buttons to select the various pages.

- **4** Play the voice.



Playing Two or Three Voices Simultaneously

- ▶ **1** Press the PART ON/OFF [RIGHT2] button to turn the RIGHT2 part ON.

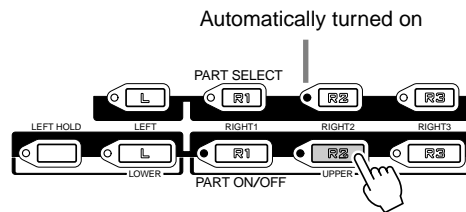

- ▶ **2** Select a voice group.
For example, select “CHOIR & PAD.”
- ▶ **3** Select a voice.
For example, select “Hah Choir.”

- ▶ **4** Play the voices.
The voice selected for R1 (page 16) and the voice selected here are sounded simultaneously in a layer.



Voice RIGHT 3 can be set in the same way described above, by using the [RIGHT3] button instead.

Try out some of these other voices...

Category	Voice Name	Comment
Piano	Live! Grand	Stereo-sampled grand piano, with realistic sound over entire keyboard range.
E.Piano	Galaxy EP	Rich and dynamic DX-type Electric Piano.
	Stage Ep	3 different dynamics sampled for realistic and expressive timbre changes.
Organ	Cool! Jazz	Organ sample with authentic chorus vibrato.
	Rotor Organ	Organ sample with real rotary speaker.
Accordion	Musette	Realistic, French type accordion.
Guitar	Live! Nylon	Stereo sampled nylon guitar. Dedicated flageolet sample for high velocities.
	Cool! J.Gtr	Dynamic, fingered jazz guitar.
	Carlos Gtr	Soulful guitar sound with natural distortion.
Strings	Live! Strs	Rich, stereo sampled strings orchestra.
	Live! Arco	Rich, stereo sampled strings orchestra with fast attack.
Trumpet	Sweet Trump	Expressive trumpet with natural vibrato.
	Sweet Tromb	Realistic trombone with natural vibrato.
	SweetMuteTp	Jazzy muted trumpet with natural vibrato.
	SweetFlugel	Soft, breathy flugelhorn with natural vibrato.

Category	Voice Name	Comment
Brass	Live! Horn	Stereo sampled powerful horn section. Sforzando style is also available.
Saxophone	Sweet Tenor	Smooth tenor sax with natural vibrato.
	Sweet Sprno	Soprano sax with natural vibrato. Very expressive. Play long notes.
	Sweet Clari	Jazzy clarinet with natural vibrato.
Flute	Sweet Flute	Flute with natural vibrato. Very expressive. Play strongly to get realistic overblown sample.
	Sweet Pan	Authentic pan flute with natural vibrato
Choir&Pad	Live!Gospel	Stereo choir with individual, smooth vibrato
	Live! Vocal	Very dynamic. The vocal "words" change depending on your playing strength. Play bass vocals with your left hand.
	DreamHeaven	Beautiful synth pad
Synthesizer	Matrix	Expressive synth lead. Play long notes.
Percussion	Live!StdKit	Stereo sampled drums with velocity switching of up to 4 layers. Also check out Live! Funk Kit.
	Live!Brush	Stereo sampled drums played by brush. Check out toms and cymbals.
	Live!Cuban / Live!PopLtn	Stereo sampled percussion with various playing styles.

Playing Different Voices with the Left and Right Hands

- 1 Press the PART ON/OFF [LEFT] button to turn the LEFT part ON.

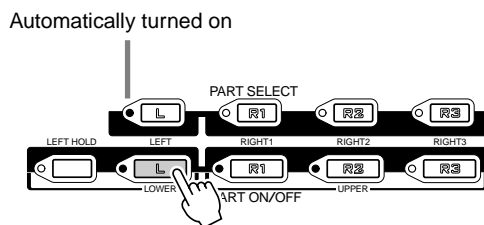

- 2 Select a voice group.
For example, select "STRINGS."
- 3 Select a voice.
For example, select "Symphon. Str."

- 4 Play the voices.
The notes you play with your left hand sound one voice, while the notes you play with your right sound a different voice (or voices).

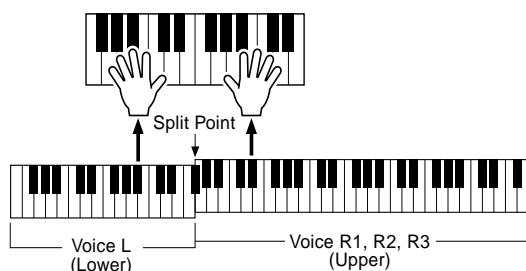

NOTE

- The point on the keyboard that separates voice LEFT and voice RIGHT1~3 is called the "split point." Refer to page 159 for instructions on setting the split point.

Voices RIGHT 1~3 are meant to be played with the right hand. Voice LEFT is played with the left hand.

Adjusting the Octave setting

The [UPPER OCTAVE] button allows the RIGHT1, RIGHT2, and RIGHT3 parts to be simultaneously transposed up or down by one octave.

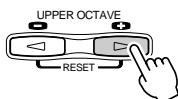

NOTE

- More detailed octave-related settings for each part can be made by using the Mixing Console function (page 145).

Organ Flutes

➔ Reference on page 62

The 9000Pro uses advanced digital modeling technology to recreate the legendary sound of vintage organs. Just as on a traditional organ, you can create your own sound by increasing and decreasing the levels of the flute footages.

- ▶ **1** Press the [ORGAN FLUTES] button.

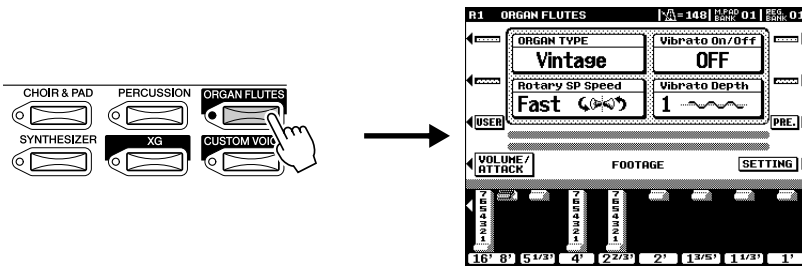

- ▶ **2** Use the LCD [1] - [8] buttons to adjust the footage settings.

The footage settings determine the basic sound of the organ flutes. The term “footage” is a reference to the sound generation of traditional pipe organs, in which the sound is produced by pipes of different lengths (in feet).

Use button [1] to adjust the 16' or 8' footage. You can select the desired footage (16' or 8') with the [E] LCD button.

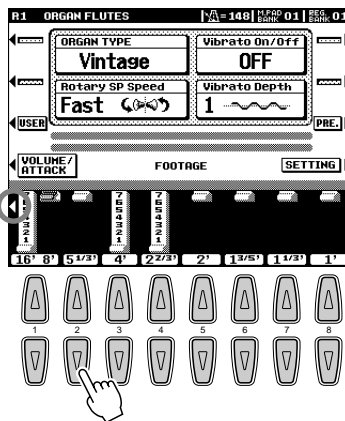

- ▶ **3** Store the Organ Flutes settings. (Refer to page 62.)

The Organ Flutes settings above are stored to Flash ROM. For details about Flash ROM, refer to “Memory Structure” on page 54.

Try out the preset Organ Flutes voices

The 9000Pro provides 10 pre-programmed Organ Flutes voices.

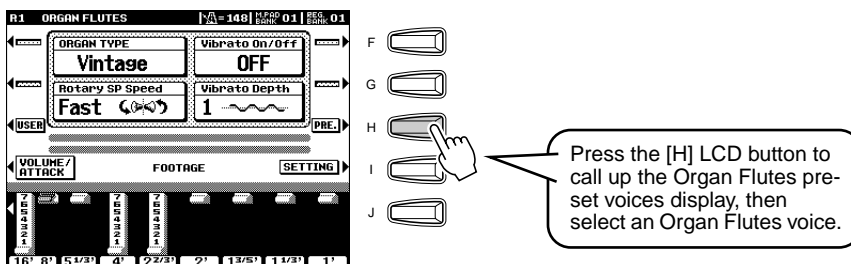

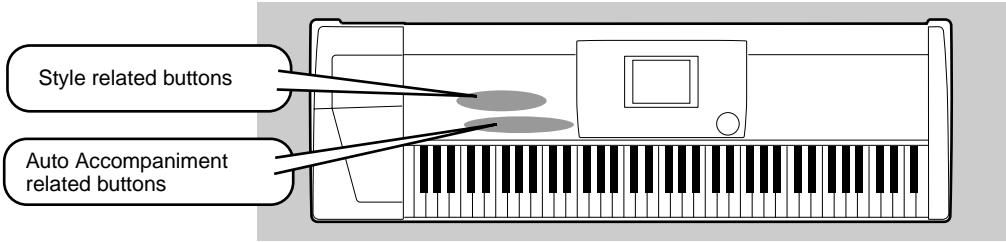

Using Auto Accompaniment

1 Select a style group.

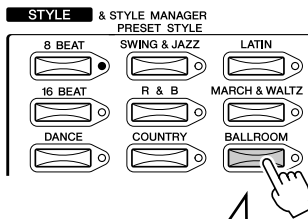

For this example, BALLROOM is selected.

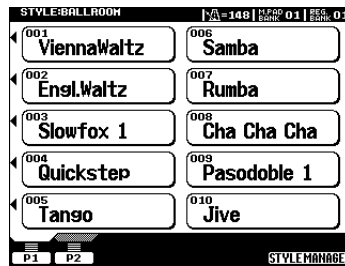

NOTE

The 9000Pro styles are divided into two groups : Preset styles and Flash styles. For details about Flash styles, see page 55.

2 Select a style.

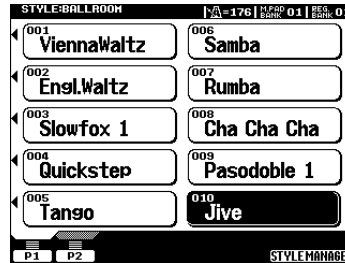

For this example, Jive is selected.

3 Turn Auto Accompaniment on.

The specified left-hand section of the keyboard becomes the “Auto Accompaniment” section, and chords played in this section are automatically detected and used as a basis for fully automatic accompaniment with the selected style.

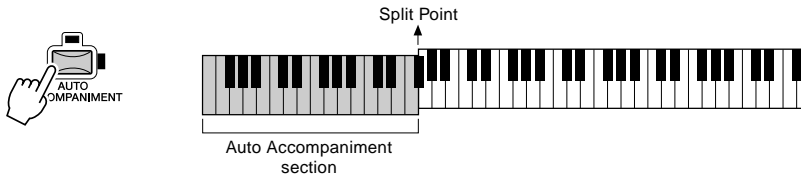

NOTE

The point on the keyboard that separates the auto accompaniment section and the right-hand section of the keyboard is called the “split point.” Refer to page 159 for instructions on setting the split point.

4 Turn Sync Start on.

The beat lamp also flashes in time with the tempo. This condition is called synchronized start standby.

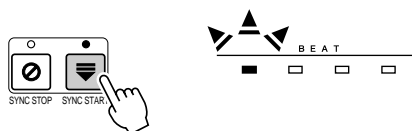

- ▶ **5** As soon as you play a chord with your left hand, the auto accompaniment starts.

For this example, play a C major chord (as shown below).

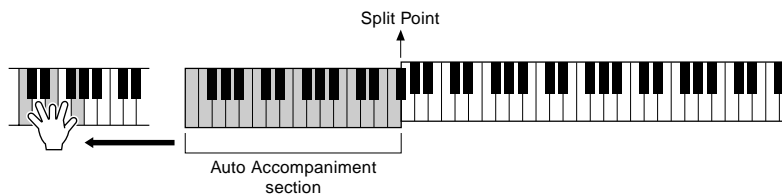

- ▶ **6** Try playing other chords with your left hand.

For information on how to enter chords, see “Chord Fingerings” on page 70.

- ▶ **7** Press the [START/STOP] button again to stop the accompaniment.

Try out some of the other styles...

Category	Style Name	Comment
8 BEAT	Heart Beat	Standard 8-beat pop. Enjoy the sound of the strumming guitars.
	Spicy Beat	Modern 8-beat that uses the Hit and Live! Standard drum kits.
	8Beat Adria	This gorgeous style evokes the north Mediterranean, but can be used well for a variety of songs.
	AcousticBld	An unplugged style with a half-time 3/4 feel. Check out the great guitar sounds.
16 BEAT	Slow & Easy	This style evokes the sophisticated, relaxed atmosphere of a modern jazz club.
	Smooth Jazz	Enjoy the Latin feel of this modern fusion style.
DANCE	House Musik	Analog synths, techno drums, rave beat — today’s modern dance music at your fingertips.
	DiscoChoco	Try starting this classic 70’s disco style with Intro III.
	Flip Hop	This contemporary hip hop rhythm features sine wave acid lines and high-pitched snare. Rap along with this!

Category	Style Name	Comment
SWING & JAZZ	Big Band 3	Traditional big band style especially suited for ballads and slow blues.
	Swingfox	Check out the different major and minor patterns for Intro III. This style is good for a wide wide range of songs.
	BBandBallad	This style is perfect for recreating the sound and atmosphere of the great big bands and orchestras of the swing era.
	Piano Swing	A swinging Pianist style. Turn the CHD1 (chord) part on and off for different arrangements.
R&B	SoulShuffle	Check out the dynamic sounds of the Live! Standard drum kit, especially in the Break fill pattern.
	GospelBros	Check out the different gospel grooves in the Main A - D patterns.
	Boogie 1	Start this out without the drums and bass, then bring them in for a full-tilt boogie band.
	RockShuffle	This heavy rock shuffle features the distortion effect on the guitar.
COUNTRY	Country 2/4	This driving country-pop style can be used for a variety of other music styles as well.
LATIN	Samba City	This contemporary Samba-pop style features dynamic toms from the new Live! drum kit. Check out Ending III.
BALLROOM	Engl.Waltz	A fully orchestrated, luscious waltz style, perfect for elegant ballroom dancing.

■ Metronome and Bass Chord Hold

These are two special styles designed for practice purposes; they do not have any of the normal rhythm or accompaniment patterns of the other styles. To call them up, select Page 2 of the Ballroom category by pressing the [P2] button.

● Metronome

This style plays back only a metronome click, without any other rhythm parts. Use this as you would a normal metronome, practicing in time with the click. You can adjust the tempo with the data dial. Playing chords in the Auto Accompaniment section of the keyboard produces corresponding bass notes and chords, just as in Bass Chord Hold below. There are five different metronome settings, each with a different time signature.

● Bass Chord Hold

Even with the auto accompaniment turned on, this style does not play any rhythm parts, but simply holds the bass note and chord that correspond to the chord you play in the Auto Accompaniment section of the keyboard. This is convenient for practicing chords without having to play along with a rhythm. There are five different bass note/chord settings, each with different voices.

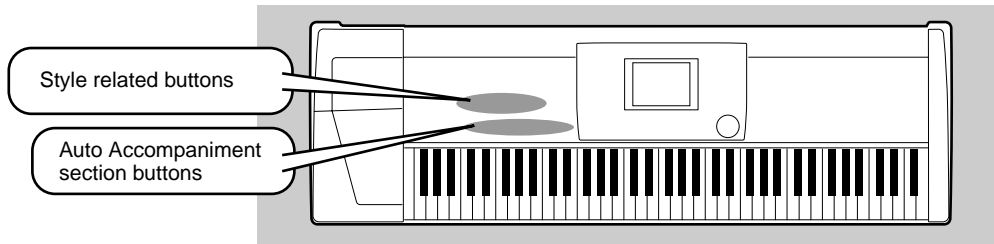

Accompaniment Sections

There are various types of Auto Accompaniment sections that allow you to vary the arrangement of the accompaniment to match the song you are playing. They are: Intro, Main, Fill-in & Break and Ending. By switching among them as you play, you can easily produce the dynamic elements of a professional-sounding arrangement in your performance.

INTRO	This is used for the beginning of the song. When the intro finishes playing, accompaniment shifts to the main section.
MAIN VARIATION	This is used for playing the main part of the song. It plays an accompaniment pattern of several measures, and repeats indefinitely until another section's button is pressed.
FILL IN & BREAK	This lets you add dynamic variations and breaks in the rhythm of the accompaniment, to make your performance sound even more professional.
ENDING	This is used for the ending of the song. When the ending is finished, the auto accompaniment stops automatically.

- ▶ **1 - 4** Use the same operations as in "Using Auto Accompaniment."
- ▶ **5** Press any of the [INTRO] buttons.

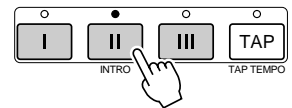

- ▶ **6** As soon as you play a chord with your left hand, the auto accompaniment starts.

For this example, play a C major chord (as shown below).

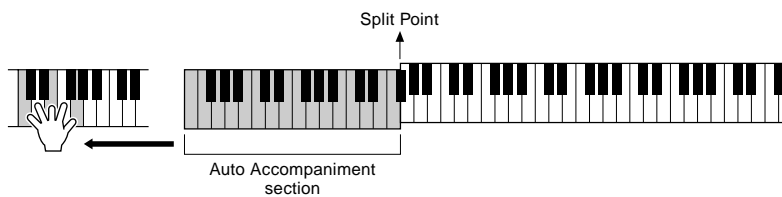

When the playback of the intro is finished, it automatically leads into main section.

- ▶ **7** Press any of the accompaniment section buttons as desired. (See the Accompaniment Structure Diagram on the next page.)

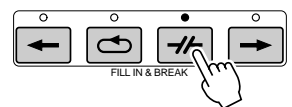

- ▶ **8** Press any of the [ENDING] buttons.

This switches to the ending section. When the ending is finished, the auto accompaniment automatically stops.

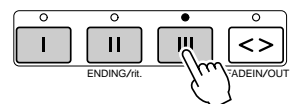

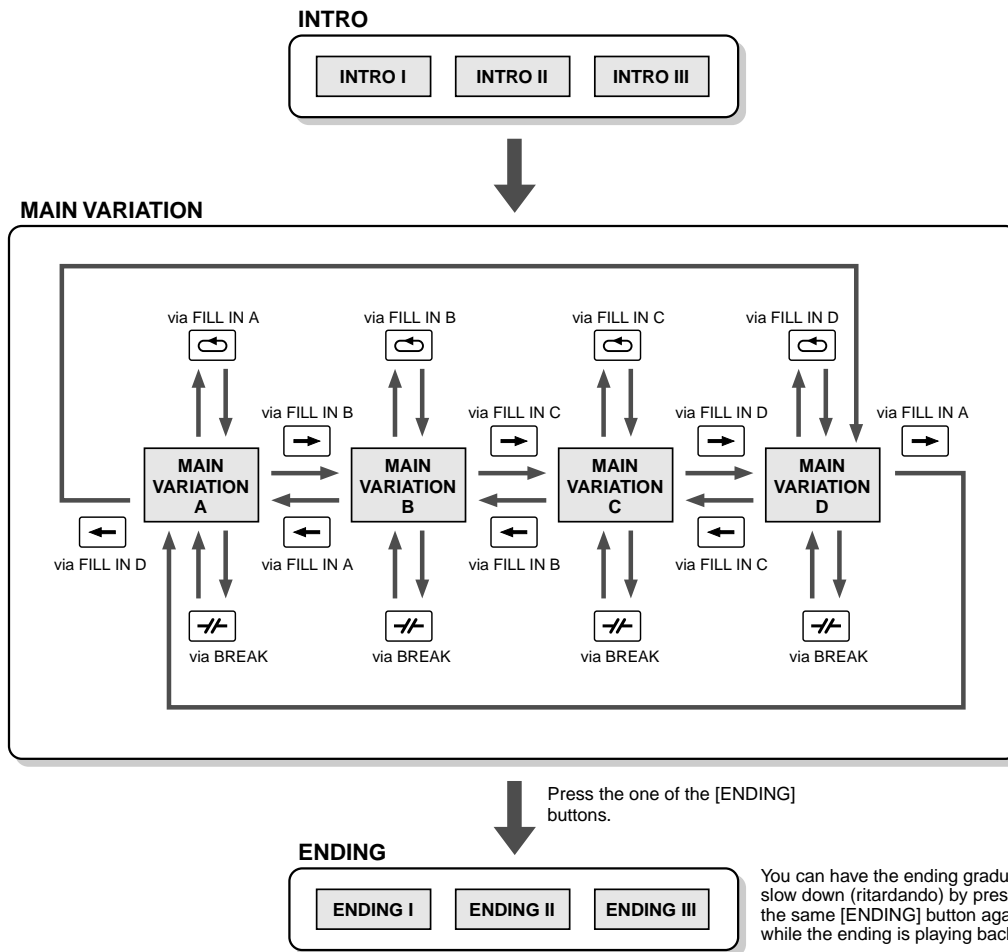

Accompaniment Structure Diagram



NOTE

- You can use one of the intro sections even in the middle of the song by pressing one of the [INTRO] buttons during the song.
- If one of the [FILL IN & BREAK] buttons is pressed after the final half beat (eighth note) of the measure, the fill-in or break will begin from the next measure.
- You can begin the accompaniment by using any of the other sections, as well as the intro sections.
- If you press one of the [INTRO] buttons while the ending is playing, the intro section will begin playing after the ending is finished.
- If you press one of the [FILL IN & BREAK] buttons while the ending is playing, the fill-in or break will immediately start playing, continuing with the main section.

Other Controls

<p>FADE IN/OUT</p>  <p>FADEIN/OUT</p>	<p>The [FADE IN/OUT] button can be used to produce smooth fade-ins and fade-outs when starting and stopping the accompaniment.</p>
<p>TAP TEMPO</p>  <p>TAP TEMPO</p>	<p>The auto accompaniment can be started at any tempo you desire by "tapping" out the tempo with the [TAP/TEMPO] button. For details, see page 72.</p>
<p>SYNCRO STOP</p>  <p>SYNC STOP</p>	<p>When the Synchro Stop function is engaged, accompaniment playback will stop completely when all keys in the auto-accompaniment section of the keyboard are released. Accompaniment playback will start again as soon as a chord or note is played. For details, see page 73.</p>

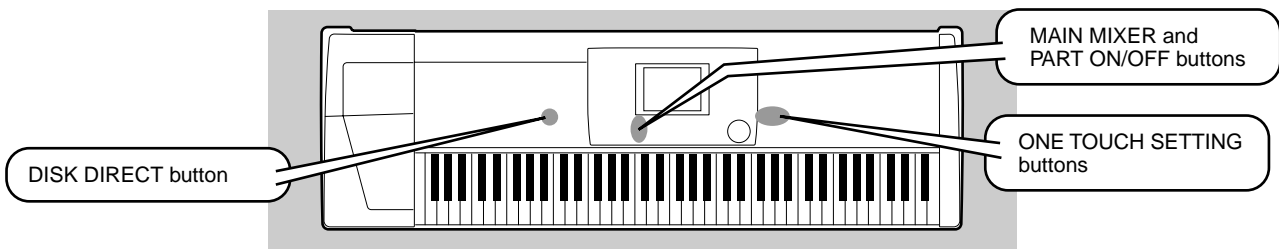

One Touch Setting

One Touch Setting is a powerful and convenient feature that automatically calls up the most appropriate panel settings (voice number, etc.) for the currently selected style, with the touch of a single button.

- ▶ **1 Select a style.**
For example, select “SWING & JAZZ” category and try out “BBand Ballad” (on P2).
- ▶ **2 Press one of the [ONE TOUCH SETTING] buttons.**
Auto Accompaniment and Sync Start will automatically be turned on. In addition, various panel settings (such as voices, effects, etc.) that match the selected style can be instantly recalled with just a single button press (see page 214).
- ▶ **3 As soon as you play a chord with your left hand, the auto accompaniment starts.**
- ▶ **4 Play melodies with your right hand and play various chords with your left hand.**
- ▶ **5 Try out other One Touch Setting setups.**
You can also create your own One Touch Setting setups. For details, refer to page 73.

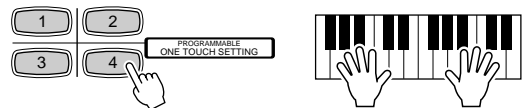
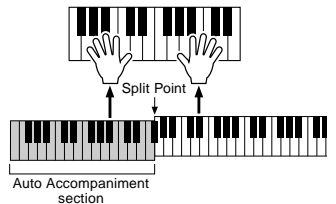
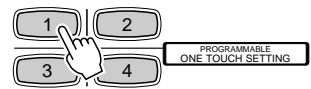

Track Muting & Volume Control

- ▶ **1 Turn Auto Accompaniment on and start the accompaniment (page 20).**
- ▶ **2 Turn individual tracks ON or OFF (muted) as required.**
 - 1) Press the [PART ON/OFF] button.
 - 2) Press the LCD button corresponding to the part you wish to turn on or off.

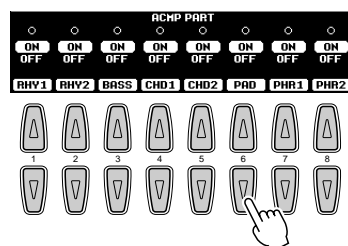
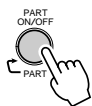

NOTE

- The ****PART**** mark below the [PART ON/OFF] button indicates that pressing the button repeatedly switches among various different displays. However, in the example explanation shown here, only the accompaniment parts are displayed; no other displays can be called up, no matter how many times the button is pressed. Other displays can be called up when Song Player (page 30) is set to on, or when the Digital Recording mode is active.

▶ 3 Adjust the volume to set the optimum level balance between the accompaniment and your right hand performance.

- 1) Press the [MAIN MIXER] button.
- 2) Press the LCD button corresponding to the part of which the volume you wish to adjust.

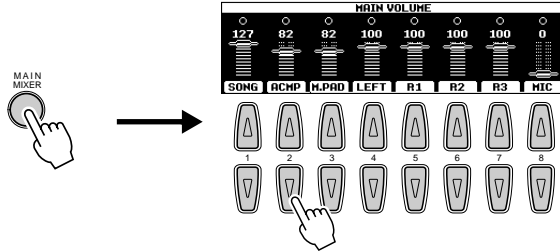

▶ 4 Stop the accompaniment (page 21).

Disk Direct Function

The 9000Pro can play back style files contained on the included floppy disk.

▶ 1 Insert the “Disk Styles” disk supplied with the 9000Pro into the disk drive.

It may take a short while for the data on the disk to be read, before you can go on to the next steps.

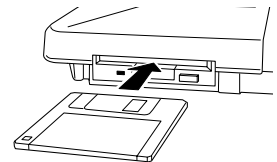

▶ 2 Press the [DISK DIRECT] button.

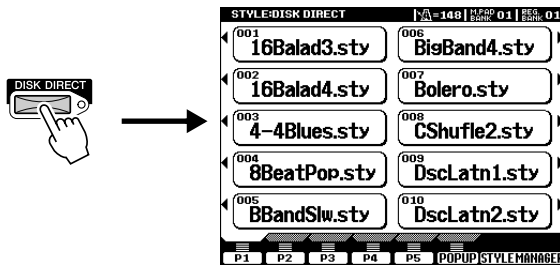

▶ 3 Select a style.

For example, select “16Balad3.”

▶ 4 Play the auto accompaniment (page 22).

NOTE

- It may be necessary to wait for a while in step #3 until the 9000Pro can play the accompaniment, since it takes some time to read the style data from the floppy disk.

■ About the Style Data

This diagram illustrates the relationship among the style data stored to different types of memory. Refer to “Memory Structure” on page 54.

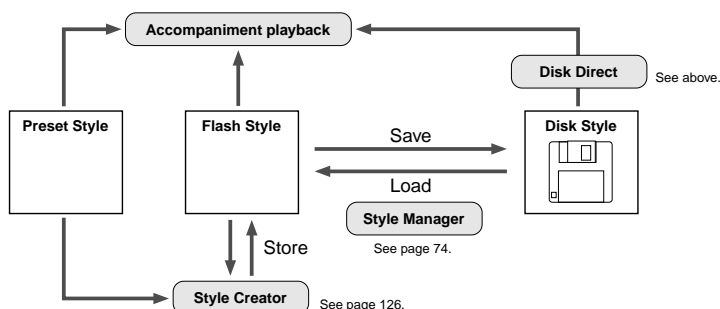

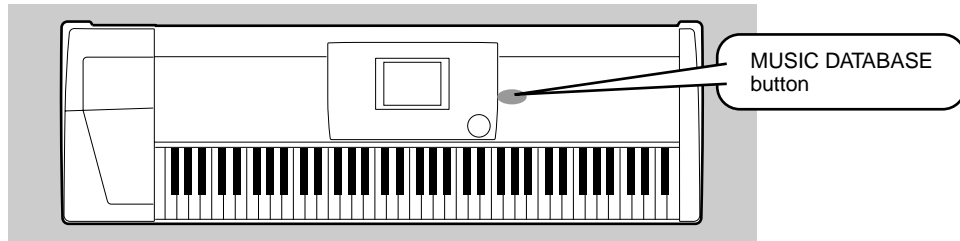

If you want to play in a certain genre of music but don't know which style and voice settings would be appropriate, the convenient Music Database can help you out. Simply select the desired genre from the Music Database and the 9000Pro automatically makes all appropriate panel settings to let you play in that music style!

For a list of Music Database setup parameters, refer to page 214.

Using the Music Database

- 1 Press the [MUSIC DATABASE] button.



- 2 Select a Music Database.

MUSIC DATABASE

CATEGORY	MUSIC DATA (TEMPO)
Great Pop Songs	Love is Deep (98)
Smooth Ballads	Saxy Tenor (98)
Golden Big Band	Swinging Sultan (152)
Swing & Jazz	Strait Guitar (152)
Evergreen	Proud of Mary (158)
Romantic Mood	Loud Guitars (158)
Easy Listening	Rocking Brass (158)
Top Hits	Days in Paradise (98)
Party Time	Heaven Strings (98)
Rock & Fusion	Called to Say (113)
Rhythm & Blues	Harp Solo (113)
Hip Hop House	White and Pale (78)
Latin Nights	Soprano Shade (78)
Country/Western	Procol Synth (78)
Ballroom Gala	I Do Everything (70)

Select the desired Category.

Press this to actually call up the Music Database

Select the desired Music Database. Use button [4] or [5] to move the cursor to the desired location and press the [OK] LCD button to actually call up the Music Database. Move the cursor to the desired location by using button [6] or [7] to call up the Music Database. (You need not press the [OK] LCD button.)

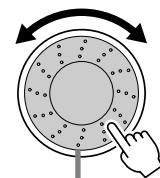

You can use the Data dial to select the desired Music Database.

For example, try out Category “Great Pop Songs” and Music Database “Called to say.”

- 3 Play along with the accompaniment playback.

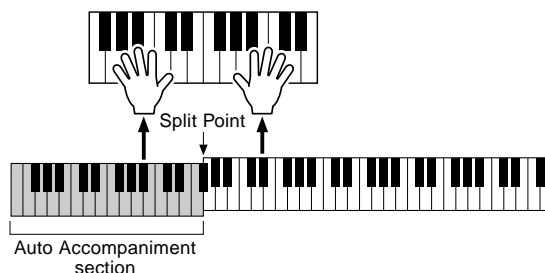

Searching the Music Database

- ▶ **1** Press the [MUSIC DATABASE] button.



- ▶ **2** Press the LCD [F] button to call up the Search display.

- ▶ **3** Select a category and set the tempo range.

- ▶ **4** Press the LCD [I] button to execute the Search operation.

- ▶ **5** Select a Music Database (see step #2 on page 26) and play along with the accompaniment playback.

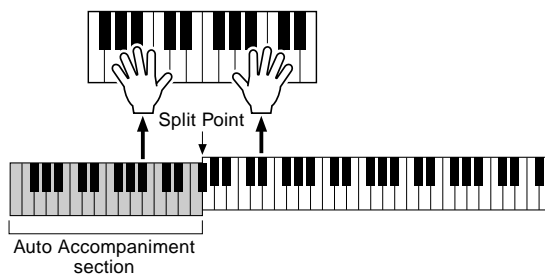

You can also create your own Music Database setups.
For details, refer to page 76.

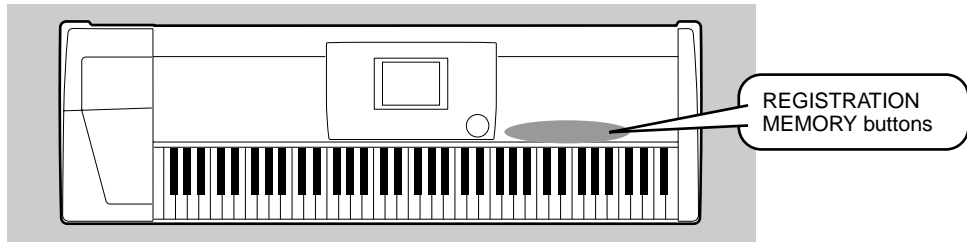

The Registration Memory gives you a convenient way to select the style, voice, and effect settings that will suit a particular type of music. You can instantly change panel settings with the touch of a single button. The Registration Memory provides up to 512 complete control-panel setups (64 banks, 8 setups each) that can be recalled instantly during your performance.

For a list of Registration Memory setup parameters, refer to page 214.

Using the Preset Registration Memory

1 Select a Registration Bank (01 through 03).

The currently selected Registration Bank is indicated at the top right of the display.

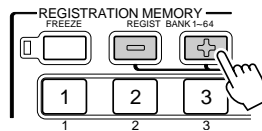

2 Press one of the REGISTRATION MEMORY buttons: [1] through [8].

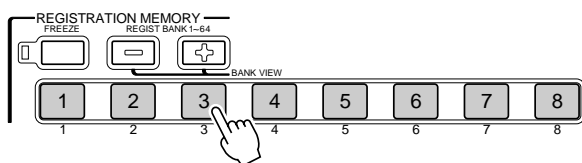

Indicates the Registration Bank/Number.

Registration Name entered via the Registration Name function display described on page 163.

If any change is made to a setting memorized by the Registration Memory feature, a pencil icon appears, indicating that one or more settings have been edited.

Current selected Registration Bank



■ The Freeze function

If you press the [FREEZE] button so that its lamp lights, selecting a different registration setup will not change the settings specified in the Registration Freeze Group Setting function display (page 163).



■ Bank View

If you press the REGIST BANK [+]/[-] buttons simultaneously, you can view the Registration Bank list on the LCD display.

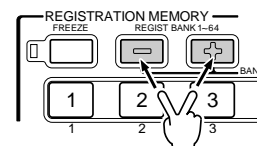

Registering the Panel Settings

You can also create your own Registration Memory setups.

- ▶ **1** Set up the panel controls as required.
- ▶ **2** Select a Registration Bank (04 through 64).
Avoid selecting one of the Registration Banks 01 through 03 (even though they can be selected), since you may inadvertently delete some important data. (See the note below.)

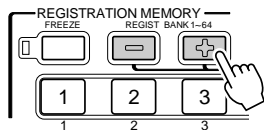

- ▶ **3** Press the [MEMORY] button.
The LCD display will prompt you to select the desired Registration number. Press the [MEMORY] button again to exit from this display.



- ▶ **4** Press one of the REGISTRATION MEMORY buttons: [1] through [8].

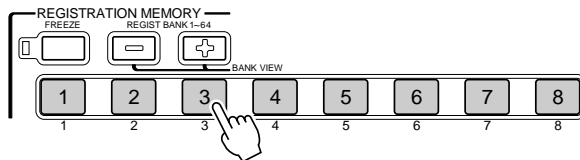

In this example, the panel settings are memorized to button number 3.

NOTE

Since all Registration Memory data is stored to Flash ROM, any data in the Registration Memory location you selected in step #2 above will be erased and replaced by your new settings. This includes the factory programmed preset Registration Memory settings (banks 01 - 03). If you've deleted the factory-set data, you can use the Restore function (page 154) to load a copy of it from the included disks (page 6).

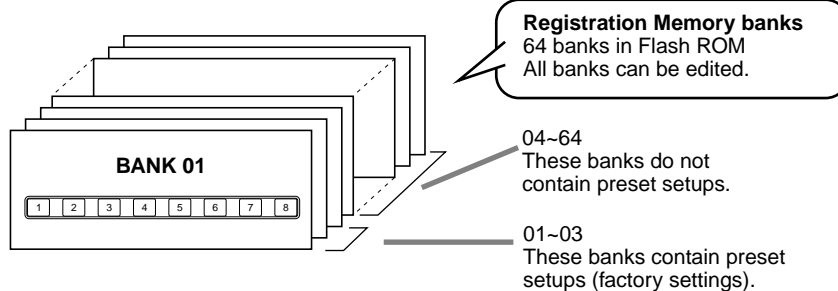

For details about Flash ROM, refer to "Memory Structure" on page 54.

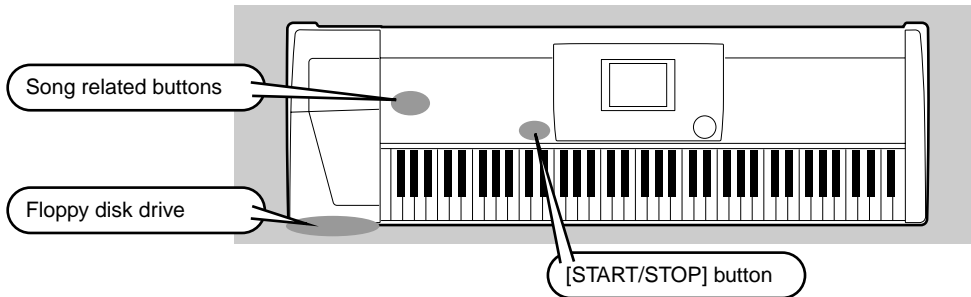

!! IMPORTANT

- Make sure to read the section "Using the Floppy Disk Drive (FDD) and Floppy Disks" on page 5.

The following disks are compatible for playback on the 9000Pro. Refer to page 6 for more details on the logos.



Disks bearing this logo contain song data for voices defined in the GM standard.



Disks bearing this logo contain song data using the XG format, an extension of the GM standard that provides a wider variety of voices and more comprehensive sonic control.



Disks bearing this logo contain song data for voices defined in Yamaha's DOC format.

NOTE

- GM song files not having the extension ".MID" in the name cannot be handled by the 9000Pro.

Playback of Song Disks

- **1** Insert the disk that contains song data into the disk drive.

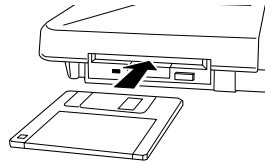

- **2** Turn the SONG PLAYER on.
- **3** Press the SONG FILE DIRECTORY [I] button.

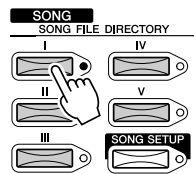

- **4** Select a song file.

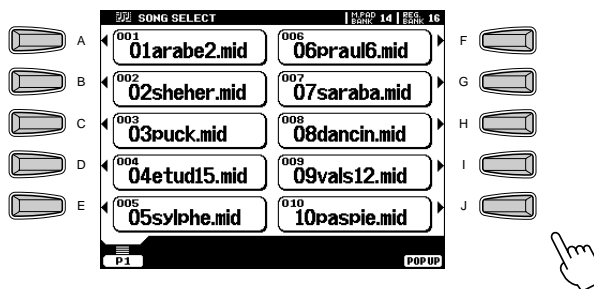

5 Start playback.



NOTE

- With song data software (Standard MIDI format 0) that includes lyrics, you can view the lyrics in the display during playback. See page 79 for details.
- For appropriate song data, the 9000Pro can display the lyrics in one of five different languages: English, German, French, Spanish and Italian.

6 Turn individual tracks ON or OFF (muted) as required.

- 1) Press the [PART ON/OFF] button.
- 2) Press the LCD button corresponding to the part you wish to turn on or off.

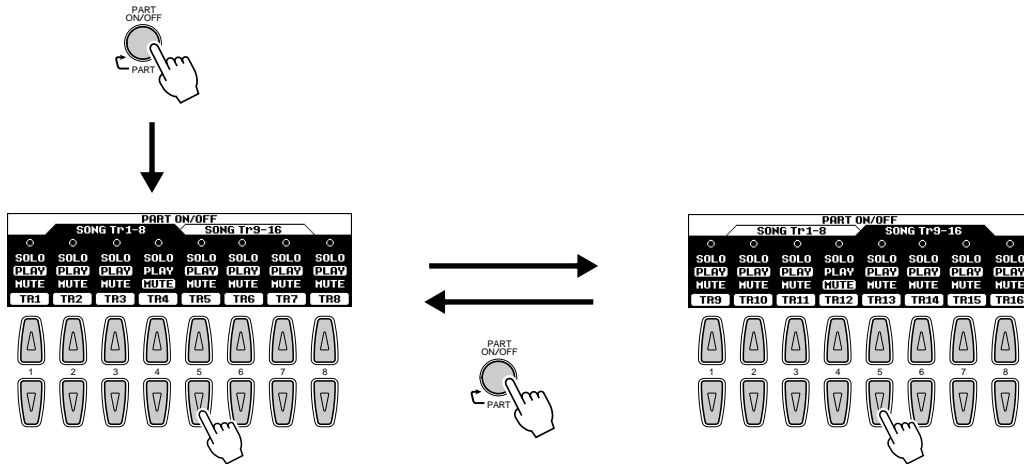

- The SOLO mode lets you select a specific part for playback, muting (turning off) all other parts.
- If you wish to practice the melody part of the XG song on the 9000Pro keyboard, set TR1 to MUTE.

7 Adjust the volume as required.

- 1) Press the [MAIN MIXER] button.
- 2) Press the LCD button corresponding to the part of which the volume you wish to adjust.

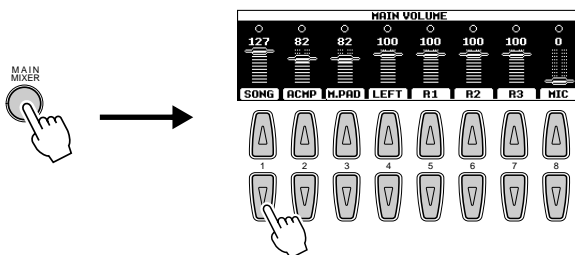

8 Stop playback.



NOTE

- The [FADE IN/OUT] button (page 72) can be used to produce smooth fade-ins and fade-outs when starting and stopping the song, as well as the accompaniment.

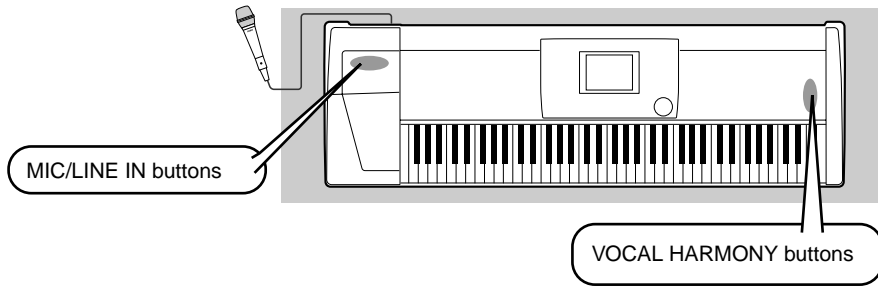

CAUTION

Pickup of extraneous sounds from the microphone can cause distorted Vocal Harmony sound.

- Separate the microphone from the speakers as much as possible.

This extraordinarily powerful feature uses advanced voice-processing technology to automatically produce vocal harmony based on a single lead vocal. In addition to straightforward harmony, the 9000Pro also lets you change the apparent gender of the harmony and/or lead vocal sound. For example, if you are a male singer, you can have the 9000Pro automatically generate a two-part female backup. A comprehensive set of parameters gives you exceptionally precise and flexible control over the vocal harmony sound.

Setting Up

- **1** Set the **INPUT VOLUME** control to “MIN.”
- **2** Set the **MIC/LINE** panel switch to “MIC 1” or “MIC 2.”
This is a gain control for the microphone input signal. The “MIC 1” setting boosts the signal, while the “MIC 2” setting reduces it.
- **3** Connect a microphone to the **MIC/LINE IN** jack of the 9000Pro.
The MIC/LINE jack accepts either 1/4” phone plugs or XLR connectors.
- **4** Adjust the **INPUT VOLUME** control while singing into the microphone.

Use the **SIGNAL** and **OVER** indicators to determine the appropriate setting. With the **INPUT VOLUME** control at the minimum, sing or talk into the microphone at the highest expected volume. Gradually bring the control up toward “MAX” so that the **SIGNAL** indicator is lit and the **OVER** indicator flashes occasionally. Then reduce the **INPUT VOLUME** just enough to keep the **OVER** indicator from flashing. This should be the optimum level setting. To hear the microphone input, make sure to set the “MIC” fader in the **MAIN VOLUME** display to an appropriate level.

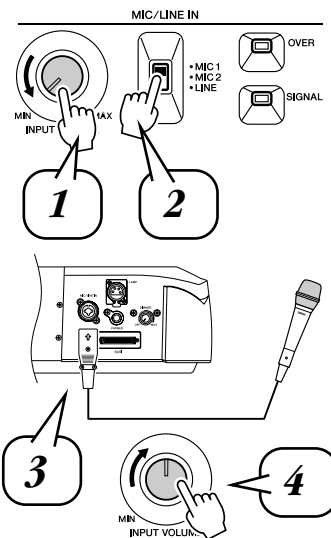

NOTE

- Refer to the important notes and caution message on page 80.

NOTE

- Turn the **INPUT VOLUME** control all the way down when disconnecting a microphone.

IMPORTANT

- Since the **MIC/LINE IN** jack is highly sensitive, it may pick up and produce noise when nothing is connected. To avoid this, **always set the INPUT VOLUME to minimum** when nothing is connected to the **MIC/LINE IN** jack.

Vocal Harmony with Accompaniment Playback

- **1** Turn **AUTO ACCOMPANIMENT** on and start the accompaniment (page 20).
- **2** Press the **VOCAL HARMONY [V.H.(9)]** button to turn the Vocal Harmony effect on.

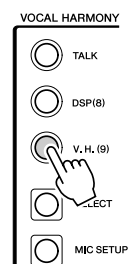

- ▶ **3** Press the VOCAL HARMONY [SELECT] button.
- ▶ **4** Select a Vocal Harmony type.

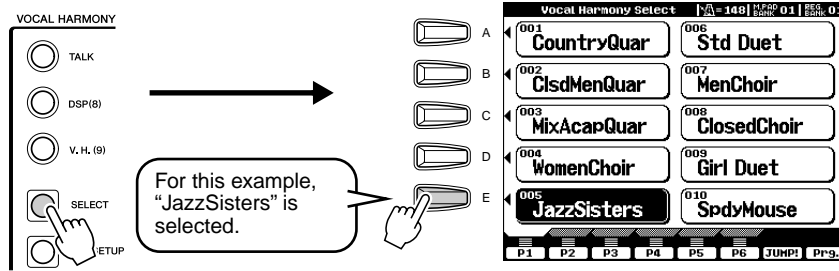

- ▶ **5** Play the keyboard while singing into the microphone.
The Vocal Harmony effect can be controlled by the chords you play in the Auto Accompaniment section (the keys to the left of the split point).

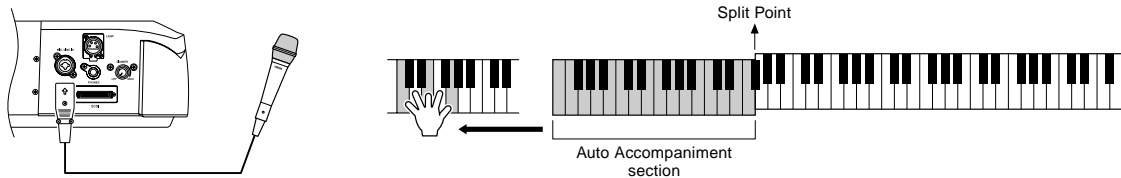

Vocal Harmony with Song Playback

The 9000Pro can properly play back disk songs that contain Vocal Harmony data.

- ▶ **1-4** Use the same operation as in “Playback of Song Disks” on page 30.
- ▶ **5** Turn the Vocal Harmony effect on and select a Vocal Harmony type (see above).
- ▶ **6** Press the [MIC SETUP] button and set the Vocal Harmony track.
Press the [E] or [J] button to select the bottom row of controls, then set the VOCODER track to the appropriate setting. For details on the appropriate track number (or MIDI channel) used for the Vocal Harmony effect, refer to the documentation included with the disk software.

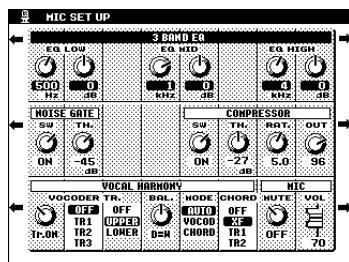

- ▶ **7** Start the song.
- ▶ **8** Sing into the microphone during song playback.
- ▶ **9** Stop the song.

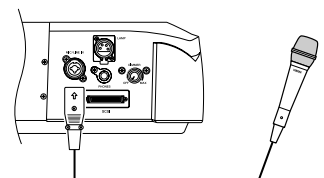

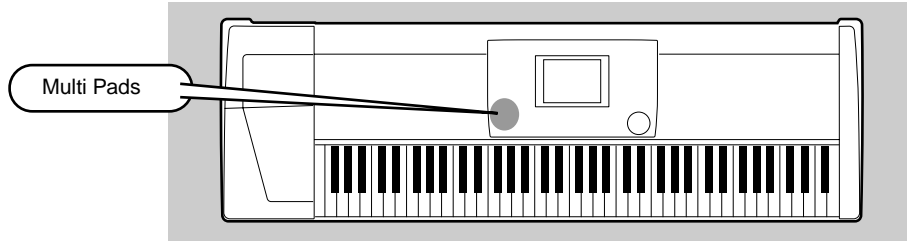

The 9000Pro Multi Pads can be used to play a number of short pre-recorded rhythmic and melodic sequences that can be used to add impact and variety to your keyboard performances.

Playing the Multi Pads

- **1** Use the M.PAD BANK [-]/[+] buttons to select a Multi Pad Bank.

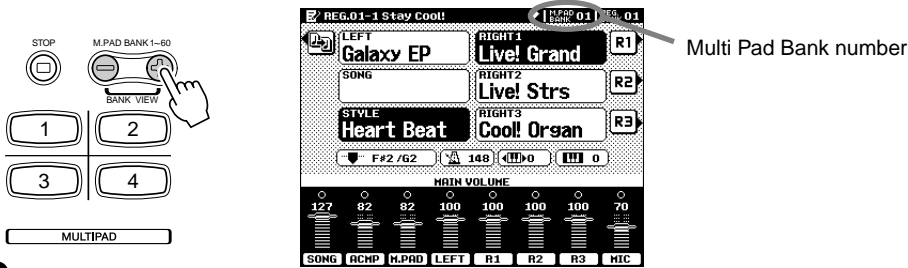

NOTE

- Simply tap any of the Multi Pads at any time to play back the corresponding phrase at the currently set tempo.
- You can even play two, three, or four Multi Pads at the same time.
- Pressing the pad during its playback will stop playing and begin playing from the top again.

- **2** Press any of the Multi Pads.

The corresponding phrase (in this case, for Pad 4) starts playing back in its entirety as soon as the pad is pressed. The Multi Pad function provides two different ways to stop in the middle of the phrase :

- To stop all pads, press and release the [STOP] button.
- To stop specific pads, simultaneously hold down the [STOP] button and press the pad or pads you wish to stop.

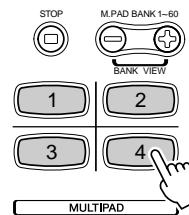

NOTE

- There are two types of Multi Pad data. Some types will play back once and stop when they reach to the end. Others will play back repeatedly until you press the [STOP] button.

Bank #	Contents
Bank 01-58	Phrases
Bank 59	MIDI messages
Bank 60	Scale tuning settings (page 158)

Chord Match

- **1** Turn AUTO ACCOMPANIMENT on (page 20).
- **2** Play a chord with your left hand and press any of the Multi Pads.

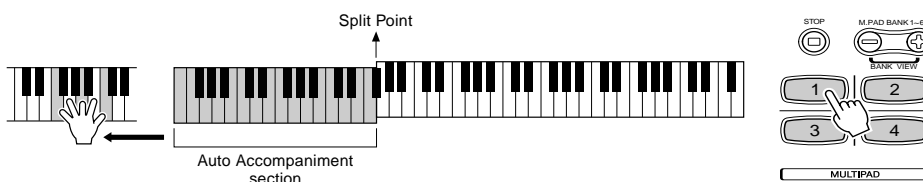

NOTE

- The Chord Match on/off status depends on the selected Multi Pad Bank.

In this example, the phrase for Pad 1 will be transposed into F major before playing back.

Try playing other chords and pressing the pads. Keep in mind that you can also change chords while a pad is playing back.

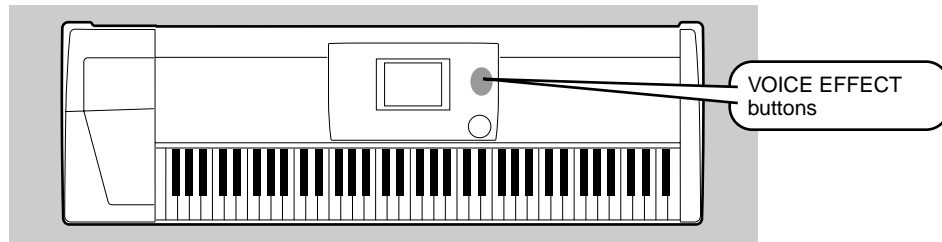

The 9000Pro features a sophisticated multi-processor effect system which can add extraordinary depth and expression to your sound.

Applying the Voice Effects

Voice Effect	Comments
TOUCH	This button turns the touch response of the keyboard on or off. When OFF, the same volume is produced no matter how strongly or softly you play the keyboard.
SUSTAIN	When this Sustain feature is ON, all notes played on the keyboard other than the Left part have a longer sustain.
DSP(4-7)	This button turns independent effects on or off for the RIGHT 1 (DSP4), RIGHT 2 (DSP5), RIGHT 3 (DSP6) and LEFT (DSP7) parts.
SLOW/FAST	The [SLOW/FAST] button can be used to switch between variations of the DSP effect. For example, this lets you change the rotating speed (slow/fast) of the rotary speaker effect.
HARMONY/ECHO	See below.
POLY/MONO	This determines whether the Part's Voice is played monophonically (only one note at a time) or polyphonically (up to 126 notes at a time).

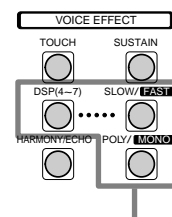

These buttons turn the corresponding effects on or off for the part currently selected via the PART SELECT buttons.

Try out the Harmony/Echo effect.

This effect adds a variety of harmony notes to your playing in the right-hand section, as well as adding tremolo or other effects.

- ▶ **1** Turn Harmony/Echo on.
- ▶ **2** Turn Auto Accompaniment on (page 20) and turn RIGHT 1 on.
- ▶ **3** Play a chord with your left hand and play some notes in the right-hand range of the keyboard.

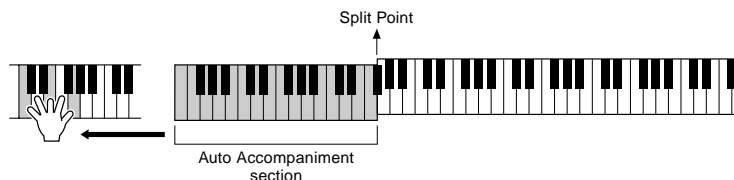

The 9000Pro has various Harmony/Echo types.

The Harmony/Echo type may change according to the selected RIGHT 1 voice.

Try out some of the voices below.

Try out Harmony/Echo with some of the voices below...

Category	Voice	Harmony/Echo Type
PIANO	Grand Piano	Standard Trio
ACCORDION	Tutti Accrd	Country Trio
STRINGS	Live! Strs	Block
	ChamberStrs	4-way Open
GUITAR	Lead Guitar	Rock Duet w/touch Sen

Category	Voice	Harmony/Echo Type
GUITAR	PedalSteel	Country Duet
BRASS	MoonLight	Full Chord
PERCUSSION	Vibraphone	Trill
GUITAR	Mandolin	Tremolo
STRINGS	Harp	Strum

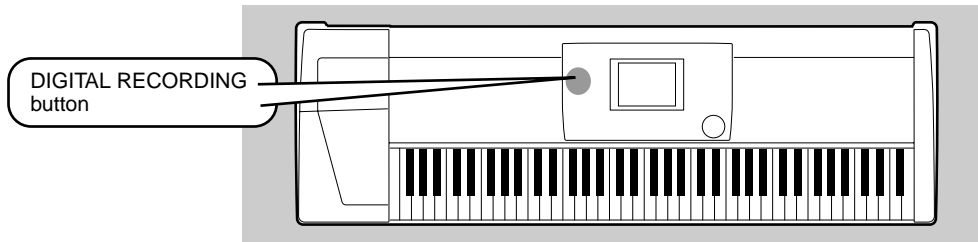

The powerful and easy-to-use Song Creator feature lets you record your own keyboard performances to disk. With multiple tracks for recording, comprehensive editing features, plus the use of the auto accompaniment and the Multi Pads, you can record complex, fully orchestrated pieces of music in any music style or arrangement — from solo piano and church organ to rock band, big band, Latin ensemble, and even a full symphony orchestra — quickly, easily and all by yourself!

Quick Recording

- **1** Press the [DIGITAL RECORDING] button to engage the Record mode.
- **2** Select “SONG CREATOR.”
- **3** Select “NEW SONG.”
- **4** Select “QUICK RECORD.”

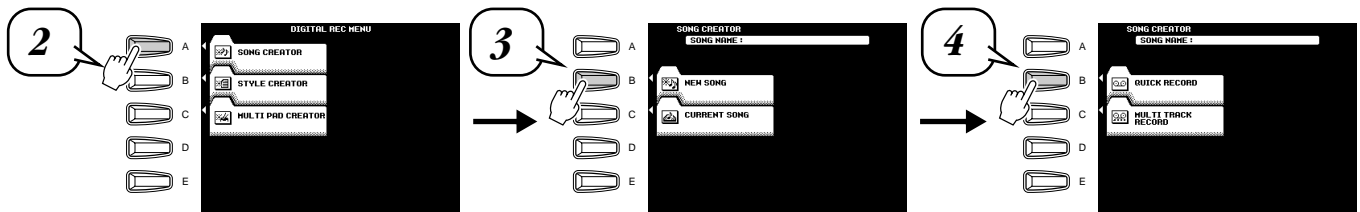
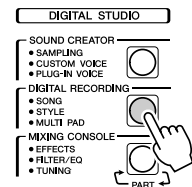

- **5** Set the track modes.
 - When MANUAL is set to “REC,” your keyboard performance and Multi Pad playback can be recorded to the corresponding tracks as listed below.
 - When ACMP is set to “REC,” Auto Accompaniment is automatically set to on and accompaniment playback can be recorded to the corresponding tracks as listed below.

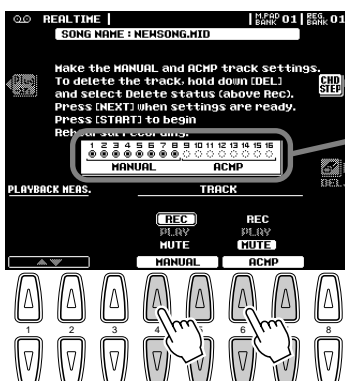

The voices, Multi Pad notes, and accompaniment parts are recorded to the various tracks as listed below.

MANUAL

VOICE	TRACK
RIGHT 1 voice	1
RIGHT 2 voice	2
RIGHT 3 voice	3
LEFT voice	4
MULTI PAD 1	5
MULTI PAD 2	6
MULTI PAD 3	7
MULTI PAD 4	8

ACCOMPANIMENT

PART	TRACK
RHYTHM 1 (sub)	9
RHYTHM 2 (main)	10
BASS	11
CHORD 1	12
CHORD 2	13
PAD	14
PHRASE 1	15
PHRASE 2	16

▶ **6** Press the [NEXT] button.

▶ **7** Set up for recording.

- Select the required voice(s), select a style, if required. Set up all parameters as desired for recording.
- Turn the metronome on or off as required.

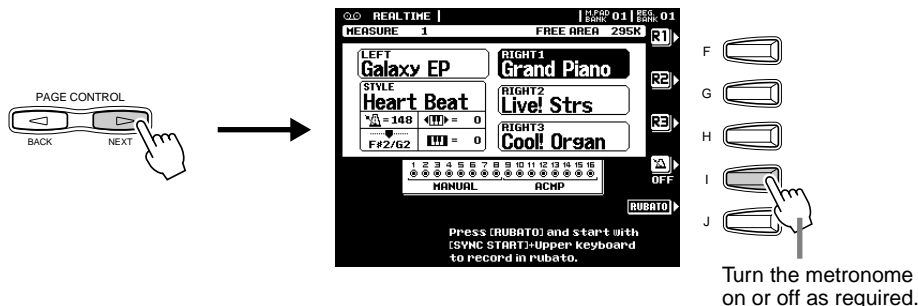

NOTE

- If ACMP is set to "REC" in step #5, you can start recording your keyboard performance first and then start recording the Auto Accompaniment or rhythm. To do this,
 - 1) Press the [RUBATO] LCD button.
 - 2) Play a key on the right side of the split point to start recording your keyboard performance.
 - 3) Play a chord on the left side of the split point to start recording the Auto Accompaniment with your keyboard performance.
- Using Registration Memory (page 28), One Touch Setting (page 24), and Music Database (page 26) can make your recording sessions much more efficient, since various settings (such as voices, etc.) can be recalled by a single button press.

▶ **8** Start recording.

Recording starts as soon as you play a key on the keyboard.



▶ **9** Stop recording.

When you finish playing, press the [START/STOP] button.

If you have set ACMP track to REC in step #5 above, you can stop recording by pressing the [ENDING] button. If you press the [ENDING] button, recording will stop automatically after the ending section has finished.

▶ **10** Press the [START/STOP] button to hear your newly recorded performance.

▶ **11** Save the recorded data to the disk.

Insert a blank recordable disk into the disk drive, and follow the instructions in the illustrations below.

CAUTION

- While the file is being saved, never eject the floppy disk or turn the power off.

CAUTION

- Please note that the recorded data will be lost if exiting from the Record mode without saving the data to disk.

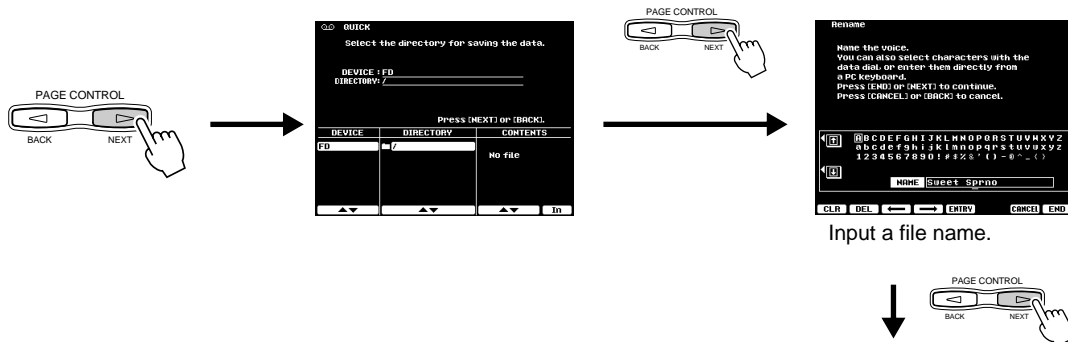

The LCD display will prompt you to save the recorded data. At the prompt, select "YES" to save the recorded data.

▶ **12** Press the [EXIT] button to exit from the Record mode.

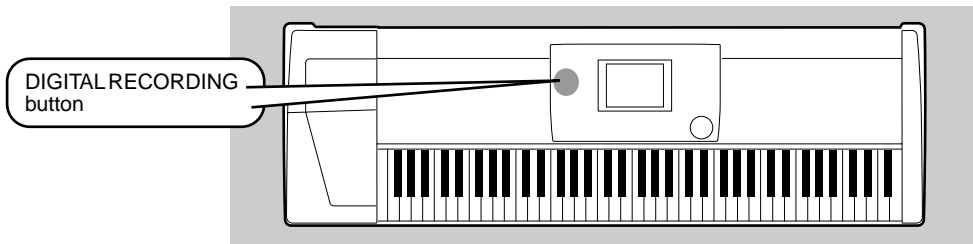

Multi Track Recording

- **1** Press the [DIGITAL RECORDING] button to engage the Record mode.
- **2** Select "SONG CREATOR."
- **3** Select "NEW SONG."
- **4** Select "MULTI TRACK RECORD."

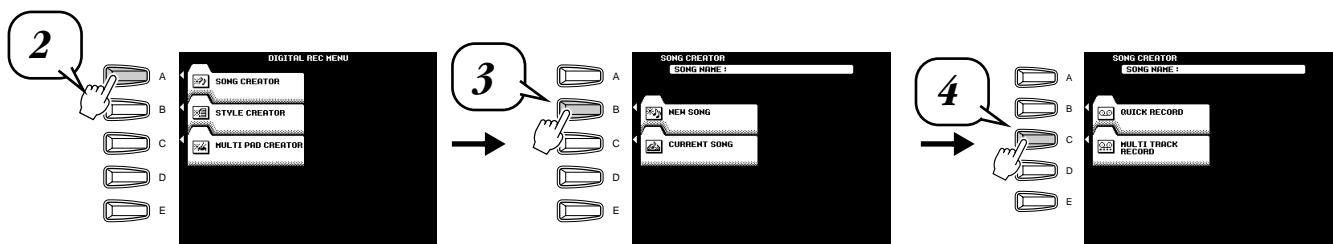
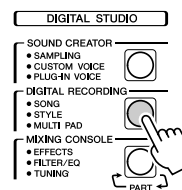

➤ **5** Set the track modes.

- When set to "REC," your keyboard performance and Multi Pad playback can be recorded to the corresponding tracks.
- When one of the TR11~16 is set to "REC," Auto Accompaniment is automatically set to on and accompaniment playback can be recorded to the corresponding tracks as listed in the caption below.

Use this button to alternately switch between the Part selecting and the Record selecting.

Use this button to alternately switch between the TR1~8 and the TR9~16 settings.

Set the desired track to "REC."

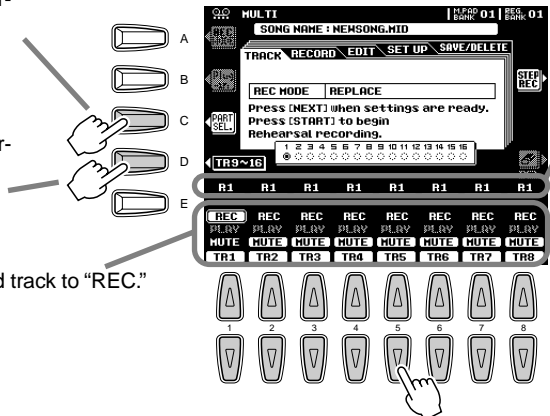

Select the part for the corresponding track. The available parts for all tracks are:

- RIGHT1
- RIGHT2
- RIGHT3
- LEFT
- MULTI PAD1~4
- RHYTHM1
- RHYTHM2
- BASS
- CHORD1
- CHORD2
- PAD
- PHRASE1
- PHRASE2
- VHRM
- MIDI

▶ **6** Press the [NEXT] button.

▶ **7** Set up for recording.

- Select the required voice(s), select a style, if required. Set up all parameters as desired for recording.
- Turn the metronome on or off as required.

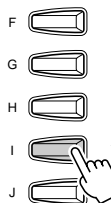
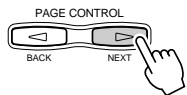

Turn the metronome on or off as required.

NOTE

• Pressing the [REHEARSAL] LCD button before recording lets you practice the part to be recorded. This is particularly convenient for mastering parts for punch-in recording — before you actually record them.

▶ **8** Start recording.

You can start recording with one of the following ways:

- Press the [START/STOP] button to start the rhythm parts of the accompaniment and recording at the same time.
- Press the [SYNC START] button to enable synchronized standby, then play a key on the left side of the split point to start the accompaniment and recording at the same time.
- Press the [SYNC START] button to enable synchronized standby.
 - 1) Play a key on the right side of the split point to start recording.
 - 2) Play a key on the left side of the split point to start the accompaniment.



NOTE

• If one of the TR11~16 is set to "REC" in step #5, you can start recording your keyboard performance first and then start recording the Auto Accompaniment or rhythm. To do this,

- 1) Press the [RUBATO] LCD button.
- 2) Play a key on the right side of the split point to start recording your keyboard performance.
- 3) Play a chord on the left side of the split point to start recording the Auto Accompaniment with your keyboard performance.

• Using Registration Memory (page 28), One Touch Setting (page 24), and Music Database (page 26) can make your recording sessions much more efficient, since various settings (such as voices, etc.) can be recalled by a single button press.

▶ **9** Stop recording.

When you finish playing, press the [START/STOP] button.

If you have set the accompaniment tracks to REC in step #5 above, you can stop recording by pressing the [ENDING] button. If you press the [ENDING] button, recording will stop automatically after the ending section has finished.

▶ **10** Press the [START/STOP] button to hear your newly recorded performance.

Repeat step #5 - #9 as needed.

▶ **11** Save the recorded data to the disk.

Insert a blank recordable disk into the disk drive, and follow the instructions in the illustration below.

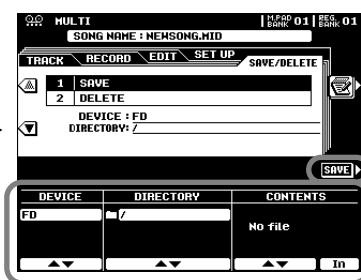
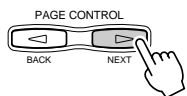

Press this button to execute the save operation.

CAUTION

• While the file is being saved, never eject the floppy disk or turn the power off.

CAUTION

• Please note that the recorded data will be lost if exiting from the Record mode without saving the data to disk.

▶ **12** Press the [EXIT] button to exit from the Record mode.

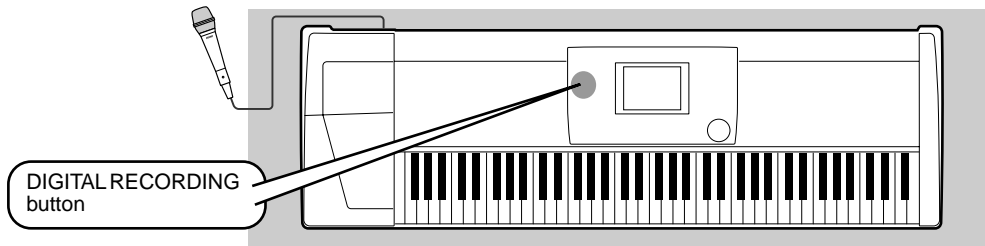

This function lets you record your own sounds via a microphone. Once it is recorded, the resulting “sample” can be played at various pitches from a keyboard.

Recording a Sample

➤ **1-4** Use the same operation as in “Setting up” (page 32).

➤ **5** Press the [SOUND CREATOR] button.

➤ **6** Select “SAMPLING.”

➤ **7** Select “RECORDING.”

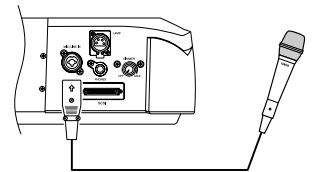
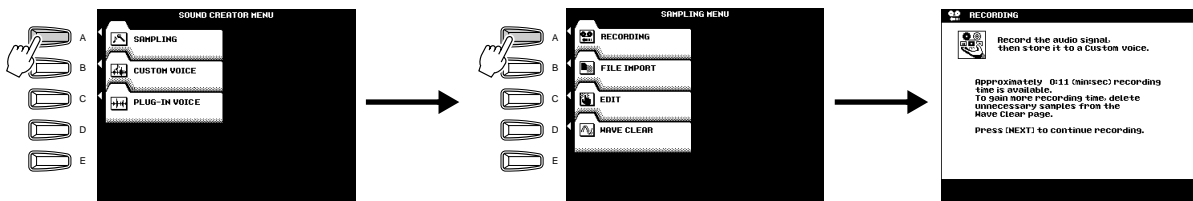

NOTE
• The notes and cautions contained on page 80 also apply to Sampling.

➤ **8** Press the [NEXT] button.

➤ **9** Set the key range to which the new sample will be assigned.

➤ **10** Press the [NEXT] button twice to call up the sample recording display.

NOTE
• Since this is the first sample you are recording, it is automatically assigned and fixed to the lowest available key. As a result, the START KEY cannot be set.

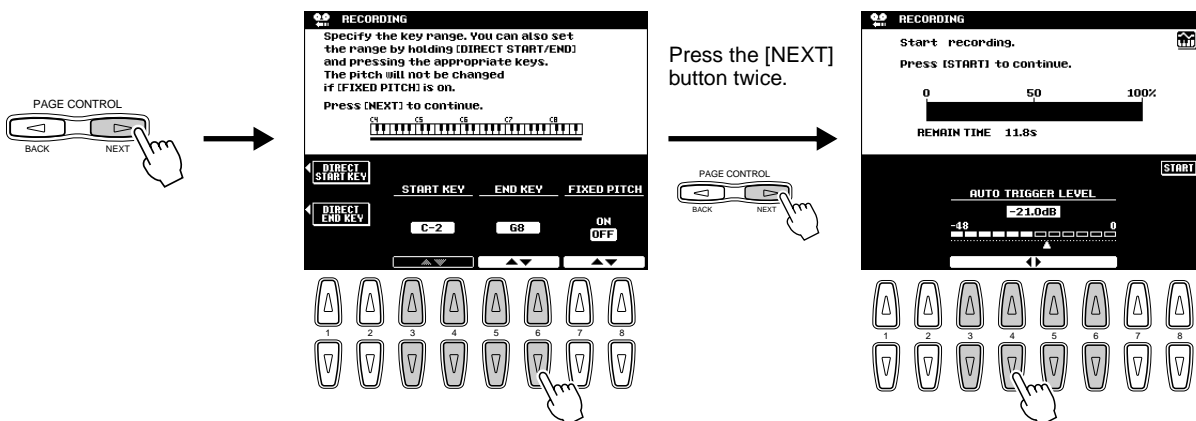

- ▶ **11** Press the LCD [START] button and speak into the microphone to start the sampling.
Sampling starts when the input level reaches the Auto Trigger level (page 84).



- ▶ **12** Press the LCD [STOP] button to stop the sampling.
Sampling will stop automatically when the available wave memory is full, so be sure to press LCD [STOP] button as soon as the sound you want to sample is recorded, otherwise you'll end up sampling unwanted silence (which can be edited out later).

- ▶ **13** Store voice parameters for the recorded sample as a Custom voice.
1) Follow the instructions in the chart below.

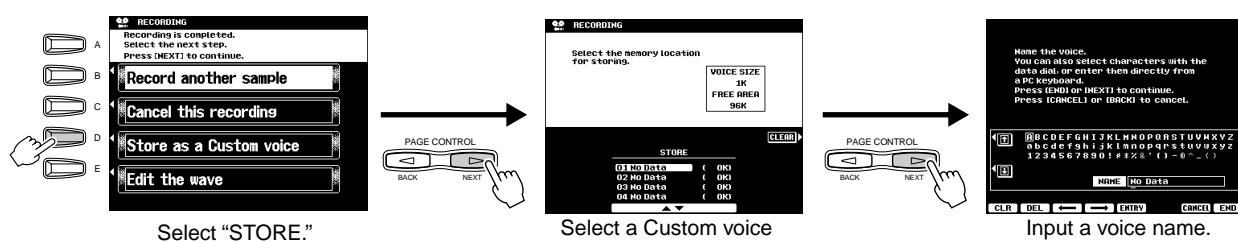

- 2) Press the [NEXT] button to store the voice parameters for the recorded sample as Custom voice.

- ▶ **14** Press the [EXIT] button several times to exit from the Sampling mode.

- ▶ **15** Select the Custom voice number above and play the voice from the keyboard.

- ▶ **16** Save the recorded sample (wave data) to disk.

- 1) Press the [DISK/SCSI] button to call up the Save display.
- 2) Select "SAVE TO DISK."
- 3) Call up the Custom Voice display and select the number stored in step #13.
- 4) Save the selected Custom Voice with the sample (wave data) to disk.



Using the Optional Plug-in Board

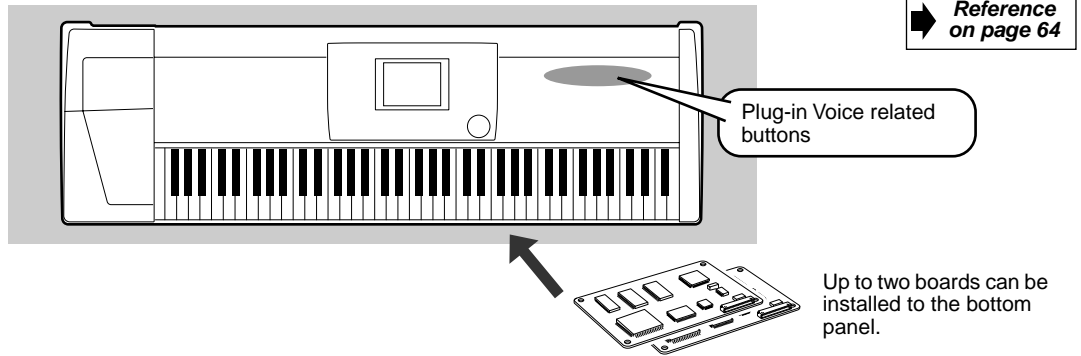

Installing an optional Plug-in Board to the 9000Pro lets you greatly expand the sonic palette of the instrument. Once you've installed an optional Plug-in Board to the 9000Pro, you have instant access to a whole new set of amazing, dynamic voices, in addition to the built-in voices of the 9000Pro.

Playing a Plug-in Voice

- ▶ **1 Install the Optional Plug-in Board to the 9000Pro.**
See page 180 for installation instructions.

In this example, a PLG150-VL Virtual Acoustic Plug-in Board has been installed to SLOT 1. The PLG150-VL lets you expand the sonic palette of your 9000Pro by adding 256 dynamic VL voices (including 137 VL-XG voices), created with the unique Virtual Acoustic Synthesis system.

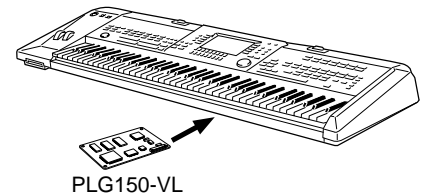

- ▶ **2 After you've installed the Plug-in Boards, turn the power ON.**
When turning the power ON for the first time after installing the board, a message appears indicating that the board settings are being initialized, followed after a while by the main display.
Note that it takes a short amount of time before the main display appears, especially if two boards have been installed. If an error message appears, check that the board or boards have been properly installed to the 9000Pro.

- ▶ **3 After the main display appears, insert the "Plug-in Custom Voice" disk supplied with the 9000Pro and load the file "150VL CsVce.xvc" to the 9000Pro via the Plug-in Manager function. See page 66 for details.**

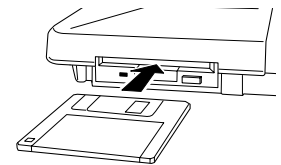

- ▶ **4 Press the [R1] LCD button to turn the RIGHT1 part on.**

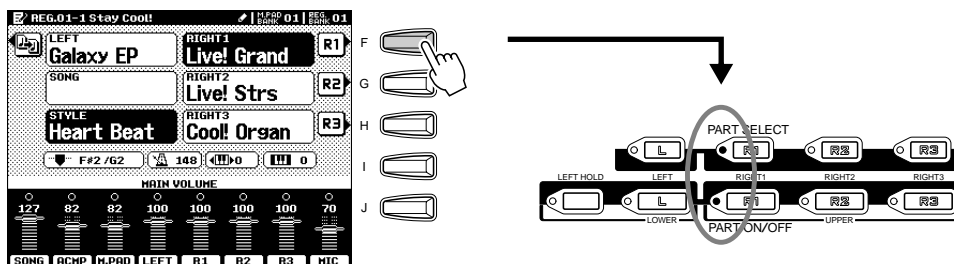

5 Press the [SLOT 1] button and select a voice group.

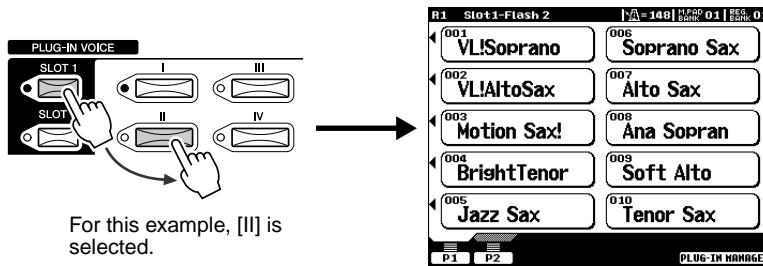

For this example, [II] is selected.

NOTE

• A single Plug-in Board can only sound one part (one Plug-in voice) at a time. This means that the playing methods described on page 17 (turning parts R1 - R3 on simultaneously) and page 18 (turning parts R and L on simultaneously) cannot be used, even if you select the same slot's Plug-in Board voices for the R1 - R3 and L parts.

6 Select a voice.

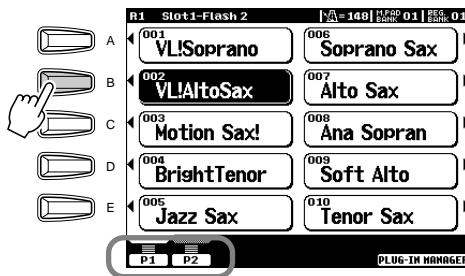

Press the corresponding buttons to select the various pages.

NOTE

• Please note that even though a Multi-Part Plug-in Board (e.g., PLG100-XG) can be used with the 9000Pro, the voice list of the slot corresponding to the Multi-Part board cannot be displayed in the LCD. See page 65 for details about the Multi-Part Plug-in Board.

7 Play the keyboard.

Up to a maximum of two Plug-in Boards can be installed to the 9000Pro (using both SLOT 1 and SLOT 2), giving you access to an extraordinarily wide range of sounds.

■ Plug-in Voices and Board Voices

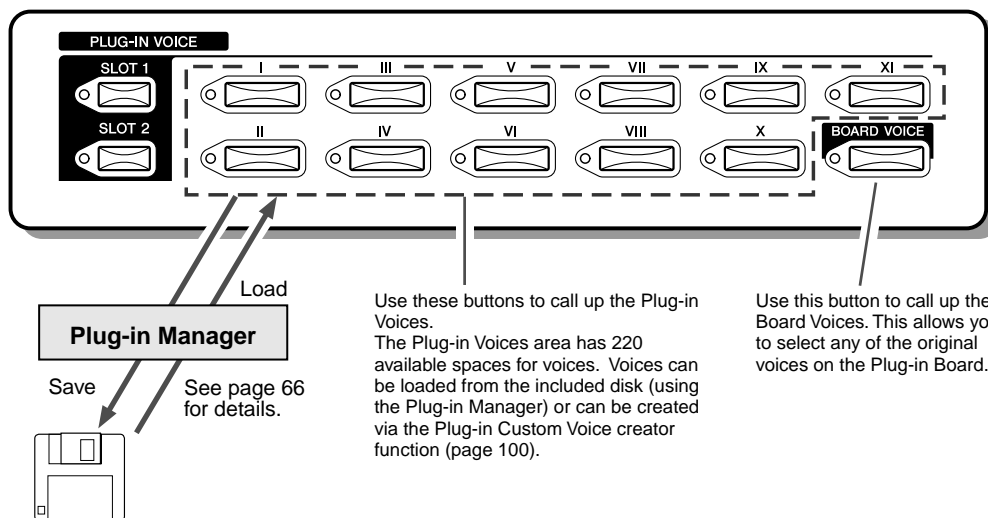

The included floppy disk features specially programmed data (such as effect settings, etc.) for using the Plug-in Board Voices with the 9000Pro.

- Before loading the disk data, the Board Voices (without any special processing or programming) are divided into groups of ten and are selectable from the PLUG-IN VOICE buttons [I] - [XI].
- Once the data on the disk is loaded, you have a new set of voices, programmed specifically for optimum use with the 9000Pro. For a list of the available Plug-in Voices created with the data on the included floppy disk, see page 204.

See pages 64 and 100 for details.

Display-based Controls

As you've seen in "Quick Guide" above, the 9000Pro features an exceptionally large and easy-to-understand display. It provides comprehensive at-a-glance information on all current settings, and gives you convenient, intuitive control over the 9000Pro's functions.

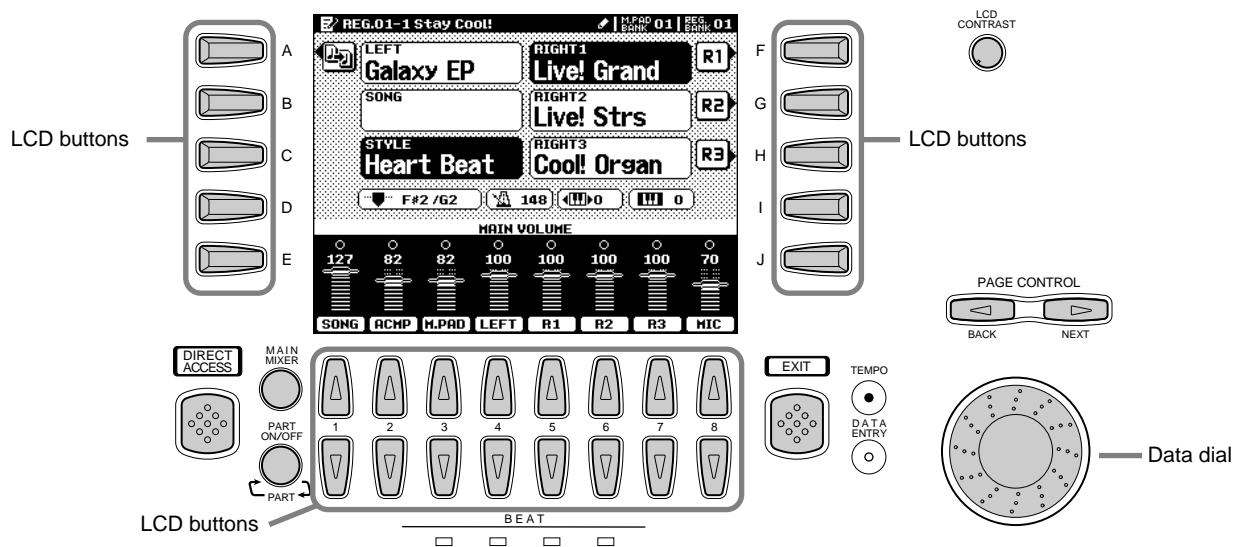

● LCD buttons

The LCD (A~J) buttons are used to select the corresponding menu. In the example display shown above, for example, the LCD [F] button can be used to turn the R1 voice on.

The LCD (1~8) buttons are divided into eight sets of up/down buttons, and are used to make selections or adjust settings (up or down correspondingly) for functions shown directly above them. In the example display shown above, for example, the LCD [6] buttons can be used to adjust the volume of the R2 voice.

● Data dial

This is usually used to change the tempo of accompaniment/song playback (when the TEMPO lamp is lit). However, when certain functions (for example, Music Database selection, Naming and Mixing Console adjusting) are shown on the LCD display, this dial is used to change the corresponding data values (when the DATA ENTRY lamp is lit).

Depending on the selected display, the lamps switch between each other automatically. (This cannot be changed manually.)

Rotating the data dial to the right (clockwise) increases the value, while rotating it to the left (counter-clockwise) decreases it.

● PAGE CONTROL buttons

If you've selected several different functions' displays in succession, you can "retrace your steps" and revisit each display by using the [BACK] and [NEXT] buttons.

Pressing [NEXT] button go to the next available page and pressing the [BACK] button return to the previous available page.

● The [LCD CONTRAST] Control

The 9000Pro display panel is a liquid-crystal type which features an [LCD CONTRAST] control. Use the [LCD CONTRAST] control to set the display for optimum legibility.

● [EXIT] button

No matter where you are in the 9000Pro display hierarchy, the [EXIT] button will return you to the next highest level, or to the normal play mode display.

Since the 9000Pro has so many different displays, you may occasionally find yourself confused as to which operation's display is currently shown. If this happens, you can return to "home base" by pressing the [EXIT] button several times. This returns the 9000Pro to the default display — the same display that appears when the power is turned on.

● [MAIN MIXER] button and [PART ON/OFF] button

Refer to pages 24, 25 and 31.

● **BEAT indicators**

These indicators flash at the current tempo and indicate the current beat during accompaniment and song playback.

● **[DIRECT ACCESS] button**

See page 48.

	4/4 time	3/4 time
1st beat	■ □ □ □	■ □ □ □
2nd beat	□ ■ □ □	□ ■ □ □
3rd beat	□ □ ■ □	□ □ ■ □
4th beat	□ □ □ ■	

Display Messages

The large 9000Pro display panel facilitates operation by making it possible to display comprehensive message and prompts that will guide you through certain operations. These messages can be displayed in one of five different languages. When such messages appear, simply follow the instructions as shown by pressing the corresponding LCD button.

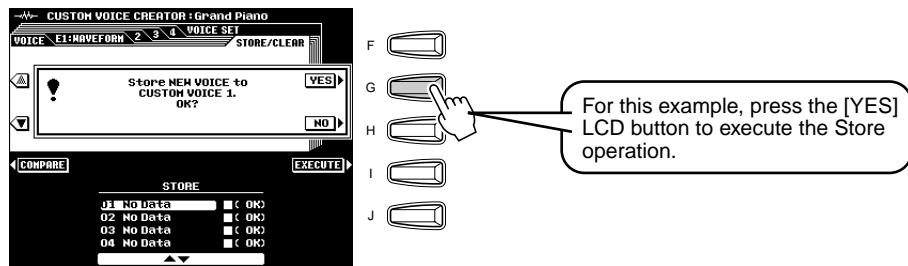

■ **Selecting the desired language of the display message**

You can select the desired language of the display messages from the following:

- English
- German
- French
- Spanish
- Italian

Follow the instructions in the chart below.

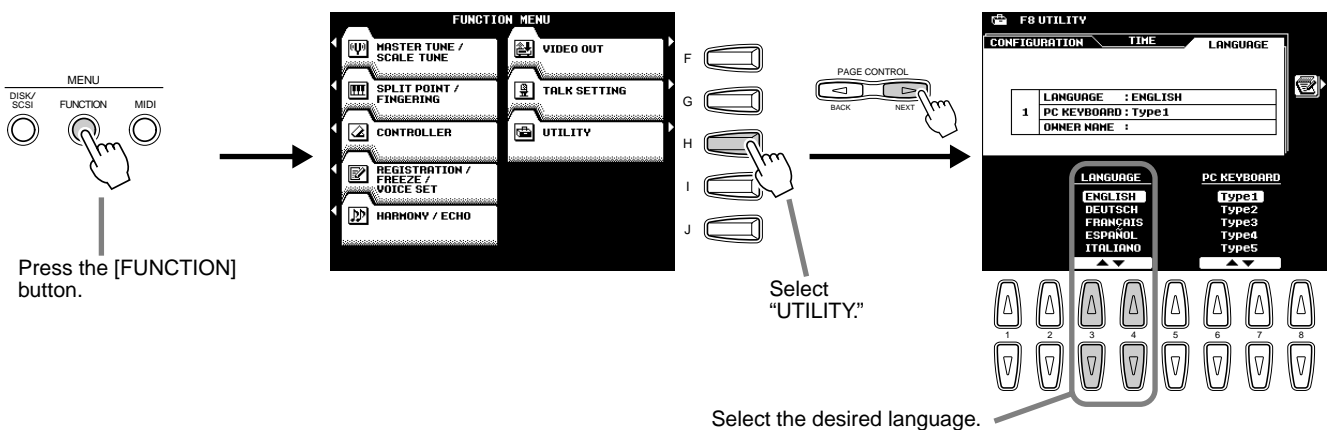

Note that the example LCD screens shown in this manual are in English.

Name Entry

A number of 9000Pro functions allow you to enter a name for, for example, a file you will be saving to disk, a custom voice or style, etc. The name entry procedure is essentially the same in all cases (only the maximum number of characters which can be entered will vary). An example display which includes NAME entry parameters is shown below:

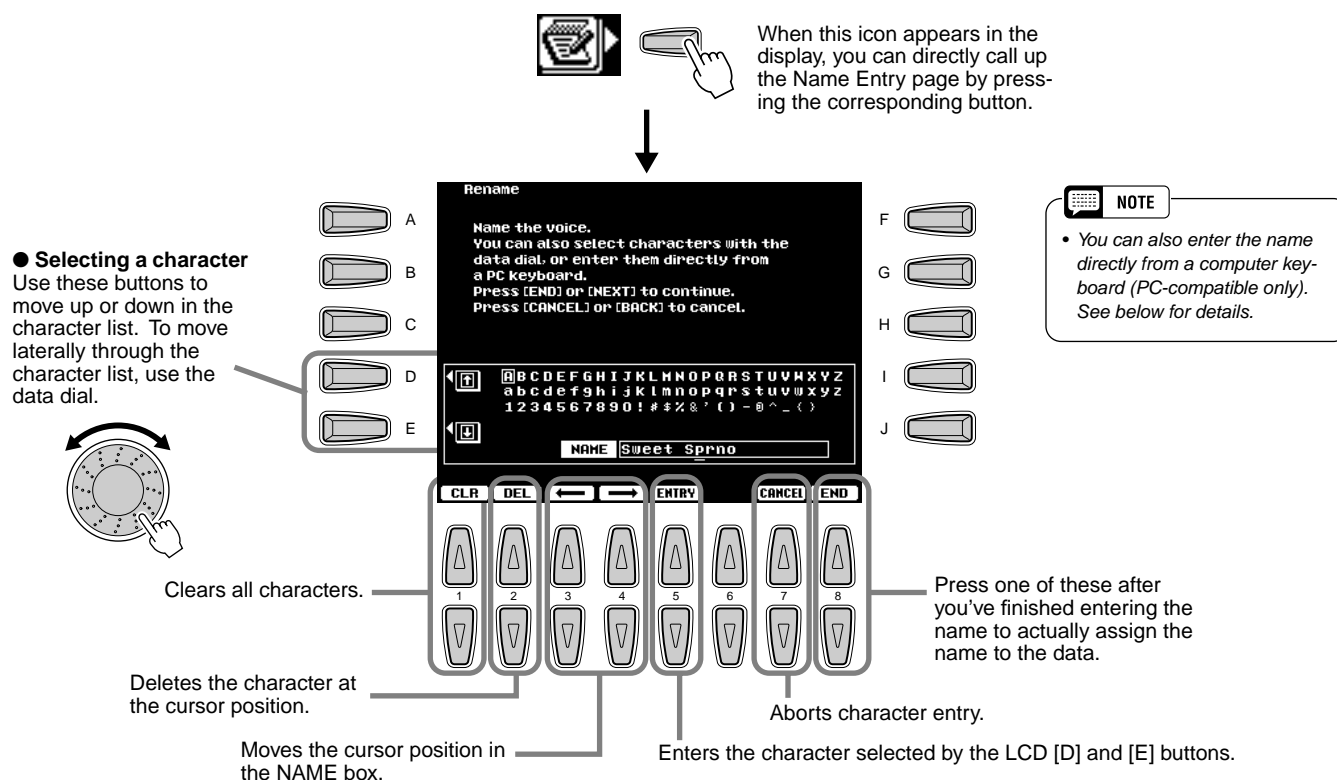

Computer Keyboard Functions

You can connect a computer keyboard (PC-compatible only) to the 9000Pro for the following functions.

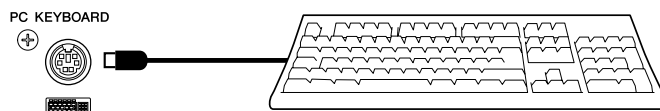

- Name Entry (see above)
- Selecting voices, styles, songs and Registration Memory settings (see below)
- Step Recording (see below)

For details on using a computer keyboard with the 9000Pro, see page 167.

Please note that Macintosh computer keyboards and USB computer keyboards cannot be used with the 9000Pro.

■ Selecting voices, styles, songs and Registration Memory settings

First, from the main display, press any key on the computer keyboard. Then select the desired category (voice, style, song, Registration Memory) by repeatedly pressing any key on the computer keyboard, with the exception of the DELETE key and the number keys. (The selected category is indicated in the display.) Then enter the desired number from the computer keyboard, according to the rules below.

- VoiceFor the internal Preset Voices:
 2 digits for the voice category, followed by 2 digits for the specific voice (or 3 digits for XG voices), then the ENTER key.
 For Plug-in Voices:
 2 digits (21 - 32 for Slot 1, 41 - 52 for Slot 2) for the voice category, followed by 2 digits (or 4 digits for Board voices), then the ENTER key.
- Style2 digits for the style category, followed by 2 digits for the specific style, then the ENTER key.
- Song2 digit for the song file directory, followed by 3 digits for the specific song, then the ENTER key.
- Registration Memory.....2 digits for the bank number, followed by 1 digit for the specific Registration Memory, then the ENTER key.

■ Step Recording

Using a computer keyboard is a very convenient way to edit events in the Event List in the Song/Style/Multi Pad step recording (pages 116, 122, 140, and 143). If you're familiar with operating a computer, you'll find many of the editing conventions that you're used to (such as moving the cursor and copying/pasting) apply to editing the 9000Pro data as well.

For a list of the parameters you can control/operate from a computer keyboard, see below.

Computer Keyboard Functions in Step Recording

Keys	Function
Number keys (0 ~9)	For typing in the desired timing (measure, beat, clock) or event data (value).
ENTER	Enters the event data (value) and moves to the next timing position.
↑	Enters the event data (value) and moves the cursor up.
↓	Enters the event data (value) and moves the cursor down.
←	Moves the cursor left
→	Moves the cursor right
BS	Deletes a character
ESC	Cancels the value entry
Insert	Inserts the new event
Delete	Deletes the event of the current location
SPACE	Same as the [START/STOP] button on the panel.
Ctrl+X	Deletes all the selected events and copies them to the clipboard.
Ctrl+C	Copies all the selected events to the clipboard.
Ctrl+V	Pastes all the event data that is currently contained in the clipboard.
Ctrl+Z	Cancels the value entry
ALT+A	Same as the LCD [A] button
ALT+B	Same as the LCD [B] button
ALT+C	Same as the LCD [C] button
ALT+D	Same as the LCD [D] button
ALT+E	Same as the LCD [E] button
ALT+F	Same as the LCD [F] button
ALT+G	Same as the LCD [G] button
ALT+H	Same as the LCD [H] button
ALT+I	Same as the LCD [I] button
ALT+J	Same as the LCD [J] button

Direct Access

By using the [DIRECT ACCESS] button, you can instantly call up the desired display. When you press the [DIRECT ACCESS] button, an LCD message prompts you to press the appropriate button. Press the button corresponding to the settings you want to display.

For this example, the display for setting the Split Point (page 159) is called up.

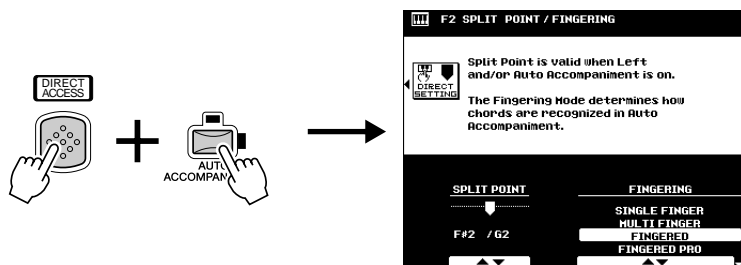

See next page for the Direct Access Chart.

Direct Access Chart

Number	Function of the accessed LCD display	Operation:  + button listed below	See pages	
1	Mixing Console	Volume/EQ settings (Main)	MAIN VARIATION [A]	144
2		Volume/EQ settings (Accompaniment)	MAIN VARIATION [B]	144
3		Volume/EQ settings (Song tracks 1 - 8)	MAIN VARIATION [C]	144
4		Volume/EQ settings (Song tracks 9 - 16)	MAIN VARIATION [D]	144
5		Filter settings (Main)	FILL IN & BREAK [←]	144
6		Filter settings (Accompaniment)	FILL IN & BREAK [↻]	144
7		Filter settings (Song tracks 1 - 8)	FILL IN & BREAK [→]	144
8		Filter settings (Song tracks 9 - 16)	FILL IN & BREAK [↗]	144
9		Effect Depth settings (Main)	VOCAL HARMONY [MIC SETUP]	144
10		Effect Depth settings (Main)	ENDING [I]	144
11		Effect Depth settings (Accompaniment)	ENDING [II]	144
12		Effect Depth settings (Song tracks 1 - 8)	ENDING [III]	144
13		Effect Depth settings (Song tracks 9 - 16)	FADE IN/OUT	144
14		Effect Type settings	VOICE EFFECT [DSP(4-7)]	145
15		Effect Type settings (Microphone Sound)	VOCAL HARMONY [DSP(8)]	145
16		Effect Parameter settings	VOICE EFFECT [SLOW/FAST]	145
17		Tune Settings (Portamento Time)	VOICE EFFECT [POLY/MONO]	144
18		Tune Settings (Pitch Bend Range)	PITCH BEND wheel	144
19		Tune Settings (Octave)	UPPER OCTAVE [+], [-]	144
20		Tune Settings (Tuning)	PART ON/OFF [R1]	144
21		Tune Settings (Tuning)	PART ON/OFF [R2]	144
22		Tune Settings (Tuning)	PART ON/OFF [R3]	144
23		Tune Settings (Tuning)	PART ON/OFF [L]	144
24		Tune Settings (Transpose)	TRANSPOSE [+]	144
25		Master EQ settings	[MIXING CONSOLE]	147
26		Master EQ settings	[MAIN MIXER]	147
27		Master EQ settings	INTRO [I]	147
28		Voice selection	[PART ON/OFF]	144
29		Voice selection	VOICE [PIANO] - [PERCUSSION]	144
30		Voice selection	INTRO [II]	144
31		Line Out settings	INTRO [III]	148
32	Function	Master Tuning	[SOUND CREATOR]	158
33		Scale Tuning	MULTI PAD [STOP]	158
34		Split Point/Fingering mode settings	[AUTO ACCOMPANIMENT]	159
35		Split Point/Fingering mode settings	[LEFT HOLD]	159
36		Foot Controller Volume settings	FOOT VOLUME	159
37		Footswitch 1 function assignment	FOOTSWITCH 1	160
38		Footswitch 2 function assignment	FOOTSWITCH 2	160
39		Modulation wheel settings	MODULATION wheel	161
40		Initial Touch setting	VOICE EFFECT [TOUCH]	162
41		After Touch setting	VOICE EFFECT [SUSTAIN]	162
42		Transpose Assign	TRANSPOSE [-]	162
43		Registration settings	REGISTRATION MEMORY [1] - [8]	163
44		Registration settings	REGIST BANK [+], [-]	163
45		Registration Memory FreezeGroupSetting	[FREEZE]	163
46		Voice Set settings (R1)	PART SELECT [R1]	163
47		Voice Set settings (R2)	PART SELECT [R2]	163
48		Voice Set settings (R3)	PART SELECT [R3]	163
49		Voice Set settings (L)	PART SELECT [LEFT]	163
50		Harmony/Echo settings	[HARMONY/ECHO]	164
51		Video monitor settings	[DEMO]	165
52		Talk Setting	VOCAL HARMONY [TALK]	165
53		AutoLoad settings	[FUNCTION]	166
54		Display MIDI Bank & Program Change #	VOICE [XG] - [CUSTOM VOICE]	166
55		Metronome Volume for Recording setting	[DIGITAL RECORDING]	166
56		Parameter Lock settings	[MEMORY]	166
57		Tap Count setting	TAP TEMPO	166
58		Auto Exit Time setting	PAGE CONTROL [BACK]	167
59		Language settings	PAGE CONTROL [NEXT]	167
60	Style Manager	Menu selection	PRESET STYLE [8 BEAT] - [BALLROOM]	74
61		Loading Style into Flash ROM	FLASH STYLE [I] - [VIII]	74
62	Style Selection	Directory selection	[DISK DIRECT]	151
63	Song Selection	Directory selection	SONG DIRECTORY [I] - [V]	78
64		Directory selection	[SONG SETUP]	78
65		Directory selection	[SONG PLAYER]	78
66	Multi Pad	Repeat settings	MULTI PAD [1], [2], [3], [4]	77
67		Chord Match settings	MULTI PAD BANK [+], [-]	77
68	DISK/SCSI	Loading Data from a Disk to Flash ROM	[DISK/SCSI]	152
69	MIDI	Clock setting	[MIDI]	175
70	VocalHarmony	Parameter settings	VOCAL HARMONY [V.H.(9)]	81
71		Parameter settings	VOCAL HARMONY [SELECT]	81
72	Music Database	Searching the Music Database	[MUSIC DATABASE]	27
73	Restoring the default tempo setting of the selected style	Data dial	-	-
74	Restoring the default tempo setting of the selected style	ONE TOUCH SETTING [1] - [4]	-	-
75	Returning to the default display (that appears when the power is turned on)	[EXIT]	-	-
76	Exiting from the Direct Access mode	[DIRECT ACCESS]	-	-

Function Tree

Numbers at the left end correspond to ones in "Top panel & connections" on page 10.

Button/Controller	LCD title	Function	See pages
1 POWER ON/OFF	–	Turning the POWER on or off	14
2 MASTER VOLUME	–	Adjusting the overall volume	14
3 PITCH BEND	–	Bending notes played on the keyboard up or down	59
4 MODULATION	–	Applying a vibrato effect to notes played on the keyboard	59
5 SONG			
[SONG PLAYER]		Turning Song Player on or off	30
[I] ... [V]		Selecting a song	30, 78
[SONG SETUP]		Setting the way in which the 9000Pro reads the song data	79
6 STYLE & STYLE MANAGER			
[AUTO ACCOMPANIMENT]		Turning Auto Accompaniment on or off	20
[8BEAT] ... [BALLROOM]		Selecting a preset style	20
STYLE MANAGER			
LOAD STYLE INTO FLASH ROM		Loading style data from disk to the internal Flash ROM	74
SAVE STYLE IN FLASH ROM		Saving style data in the internal Flash ROM to disk	75
COPY STYLE IN FLASH ROM		Copying style data in the internal Flash ROM	75
DELETE STYLE IN FLASH ROM		Deleting style data in the internal Flash ROM	75
SWAP STYLE IN FLASH ROM		Swapping style data in the internal Flash ROM	75
RENAME STYLE IN FLASH ROM		Renaming a style file in the internal Flash ROM	75
DEFRAGMENT FLASH ROM		Defragmenting the internal Flash ROM	75
[I] ... [VIII]		Selecting a style in the internal Flash ROM	55
[DISK DIRECT]		Selecting and playing a style in a disk	25
7 ACCOMPANIMENT CONTROL			
[INTRO]	–	Playing the Intro sections of the accompaniment	22
[TAP TEMPO]	–	Tapping out the tempo of the accompaniment	23, 72
[ENDING]	–	Playing the Ending sections of the accompaniment	22
[FADE IN/OUT]	–	Producing smooth fade-ins and fade-outs when starting and stopping the accompaniment/song	23, 72
[MAIN VARIATION]	–	Playing the Main sections of the accompaniment	22
[FILL IN & BREAK]	–	Playing the Fill in or Break sections	22
[SYNC STOP]	–	Turning Sync Stop on or off	23, 73
[SYNC START]	–	Turning Sync Start on or off	20
[START/STOP]	–	Starting/stopping the accompaniment	21
8 MENU			
[DISK/SCSI]			
LOAD FROM DISK			
GROUP		Loading specific type of data from a disk	152
INDIVIDUAL		Loading an individual data from a disk	152
SAVE TO DISK			
		Saving data to a disk	153
COPY FILE/FD			
COPY FILE		Copying the specified file on a disk onto another disk.	154
COPY FD		Copying the entire data on a floppy disk onto another disk.	154
BACKUP/RESTORE			
RESTORE		Restoring the data in Flash ROM	154
BACKUP		Backing up the data in Flash ROM	154
CONVERTER			
PSR-8000		Converting PSR-8000 format files to 9000Pro format files	155
SMF SONG		Converting the sequence/track name of the Meta Event in the SMF to the file name	155
EDIT FILE			
RENAME		Naming a file in a disk	155
DELETE		Deleting a file in a disk	155
EDIT DIRECTORY			
RENAME DIRECTORY		Naming a directory in a disk	156
DELETE DIRECTORY		Deleting a directory in a disk	156
CREATE DIRECTORY		Creating a directory in a disk	156
FORMAT			
FORMAT		Formatting a disk	156
CHECK DISK		Checking a disk	157

Button/Controller	LCD title	Function	See pages	
8 MENU				
[FUNCTION]	MASTER TUNE/SCALE TUNE			
	MASTER TUNE	Setting the overall pitch of the 9000Pro	158	
	SCALE TUNE	Tuning each individual note of the octave	158	
	SPLIT POINT/FINGERING			
	SPLIT POINT	Setting the point on the keyboard that separates the left-hand and right-hand section	159	
	FINGERING	Selecting the way in which chords are played with your left hand	159	
	CONTROLLER			
	FOOT CONTROLLER	Selecting the foot controller (page 13) function	159	
	PANEL CONTROLLER	Selecting the panel controller (e.g. Pitch Bend Wheel) function	161	
	REGISTRATION/FREEZE/VOICE SET			
	REGISTRATION	Naming each Registration setup/bank	163	
	FREEZE	Specifying which settings are affected by the Freeze function (page 28)	163	
	VOICE SET	Determining whether the preset settings will or will not be recalled when a new voice is selected	163	
	HARMONY/ECHO	Harmony/Echo settings	164	
	VIDEO OUT	Setting the display characteristics that are output to a television or video monitor connected to the [VIDEO OUT] jack	165	
	TALK SETTING	Setting various parameters which affect the microphone sound when the [TALK] button is on	165	
	UTILITY			
	CONFIGURATION	Setting various parameters	166	
	TIME	Setting parameters related to time	167	
	LANGUAGE	Selecting the language of the display messages	45	
	[MIDI]		Selecting a MIDI template	174
	MFC10			
	EASY SETUP	Selecting a template of the MFC10 settings	178	
	FULL SETUP	Creating and storing a template of the MFC10 settings	179	
	SETUP			
	SYSTEM	MIDI system-related parameter settings	175	
	TRANSMIT	MIDI transmit channel settings	175	
RECEIVE	MIDI receive channel settings	176		
ROOT	MIDI chord root settings	177		
CHORD DETECT	MIDI chord detect settings	177		
STORE	Storing MIDI settings as a template	177		
9 TRANSPOSE				
		Transposing up or down the pitch	61	
10 DIGITAL STUDIO				
[SOUND CREATOR]	SAMPLING	Sampling sounds via a microphone or line source	40, 84	
	RECORDING	Recording a new sample	40, 86	
	• TRIGGER LEVEL	Setting the Trigger level for starting sampling	84	
	• PRE EFFECT	Setting up a maximum of three DSP effects to be applied to the source sound	87	
	• STORE	Storing the sampled data as Custom voice	41	
	FILE IMPORT	Importing Wave files from disk	87	
	• STORE	Storing the sampled data as Custom voice	41	
	EDIT	Editing a recorded/imported sample	88	
	WAVE CLEAR	Clearing Wave data	87	
	CUSTOM VOICE			
	EASY EDIT			
	• EDIT	Editing various parameters related to tone generation (e.g., Filter, EG)	93	
	• STORE/CLEAR	Naming/Storing/Clearing Custom voice data	92	
	FULL EDIT			
	• VOICE	Editing various parameters (e.g., Initial Touch Curve, Scale Curve)	94	
	• E1:WAVEFORM	Editing various parameters related to Waveform	95	
	• E2:EG	Editing various parameters related to EG (Envelope Generator)	96	
	• E3:FILTER	Editing various parameters related to Filter	97	
	• E4:LFO	Editing various parameters related to LFO	98	
	• VOICE SET	Editing various parameters related to Voice Set	99	
	• STORE/CLEAR	Naming/Storing/Clearing Custom voice data	92	

Button/Controller	LCD title	Function	See pages
10 DIGITAL STUDIO			
[SOUND CREATOR]	PLUG-IN VOICE		
	VOICE EDIT		
	• BOARD VOICE	Selecting a Board Voice on which the Plug-in Custom Voice editing is based	102
	• E1: EG/VIB	Editing various parameters related to tone generation (e.g., Filter, EG)	103
	• E2: CTRL	Editing various parameters related to tone generation (e.g., Initial Touch Sensitivity, etc)	103
	• E3: NATIVE PRM.	Editing various parameters which are native to the installed Plug-in Board.	104
	• VOICE SET	Editing various part parameters related to Voice Set	104
	• STORE	Storing Plug-in Custom voice data	101
	NATIVE SYSTEM PARAMETER EDIT	Editing various system parameters which are native to the installed Plug-in Board.	105
	VOICE EDIT ON COMPUTER	Editing various parameters on a computer connected to the 9000Pro. Voice editing is done with special Plug-in software from the XGworks (or XGworks lite) program.	106
	BOARD CUSTOM VOICE BACKUP	Backing up the edited Board Custom Voice data from the installed Board to Flash ROM.	108
[DIGITAL RECORDING]	SONG CREATOR		
	QUICK RECORD	Recording a song quickly without having to make detailed settings	36
	• CHORD STEP	Recording accompaniment data with the Step Recording method (similar to writing out the chords in a chord chart)	122
	MULTI TRACK RECORD	Recording sixteen song tracks independently	38
	• TRACK	Setting the Record method	38
	• RECORD	Starting/stopping recording	39
	• EDIT	Editing a recorded song (e.g., Quantize, Note Shift)	114
	• SETUP	Editing Setup data (e.g., Mixing Console parameters)	115
	• SAVE/DELETE	Saving the recorded song to a disk/Deleting a song in a disk	39
	• STEP REC	Recording a song with the Step Recording method (similar to writing out the notes in music notation)	116
	STYLE CREATOR		
	EASY EDIT	Re-creating a style	129
	• STYLE ASSEMBLY	Re-creating a specific track of an already-created style.	129
	• REVOICE	Changing various parameters	130
	• GROOVE & DYNAMICS	Altering the timing for each section, velocity of notes for each track	131
	FULL EDIT	Creating a style by recording notes	132
	• BASIC	Selecting the section and track to be recorded, setting the tempo and the beat, and so on	132
	• SET UP	Editing Setup data (voice, etc.)	134
	• EDIT	Editing various parameters (Quantize, etc.)	134
	• STORE/CLEAR	Storing the created style data to Flash ROM or clearing the created style data	128
	• PARA.EDIT	Editing various parameters related to the Style File Format	135
	• STEP REC	Recording a style with the Step Recording method (similar to writing out the notes in music notation)	140
	NEW STYLE ASSEMBLY	Creating a new style	129
	MULTI PAD CREATOR		
	RECORDING	Multi Pad Recording	142
	• STEP REC	Multi Pad Step Recording	143
	CLEAR	Clearing the recorded Multi Pad data	142
	COPY	Copying the recorded Multi Pad data	142
	REPEAT	Turning Repeat on or off	142
	CHORD MATCH	Turning Chord Match on or off	142
[MIXING CONSOLE]	VOL/EQ	Adjusting the Volume, Pan and EQ high/low for each part	145
	FILT	Adjusting the Harmonic content and Brightness for each part	145
	EFF DEPTH	Adjusting the Effect (Reverb, Chorus and DSP) depth for each part	145
	EFF TYPE	Setting the Effect type/parameter for each block	146
	TUNE	Adjusting the pitch related parameters (e.g., Pitch Bend range, Portamento time) for each part	145
	M.EQ	Adjusting the overall tone of the 9000Pro, in five frequency bands	147
	VOICE	Changing the voice for each part	145
	LINE OUT	Changing the Line out setting to send the output of each part to the LINE OUT jacks.	148
11 MULTI PAD			
[M.PAD BANK 1~60]		Selecting a Multi Pad Bank	34, 77
[BANK VIEW]	REPEAT	Turning Repeat on or off	77
	CHORD MATCH	Turning Chord Match on or off	77
[STOP]		Stopping the Multi Pad playback	34
[1] ... [4]		Playing the Multi Pads	34
12 Data dial		Changing the tempo of accompaniment/song playback	44, 72

Button/Controller	LCD title	Function	See pages
13 DEMO			
[DEMO]	9000Pro DEMO	Demo song selection/playback	56
14 VOICE EFFECT			
[TOUCH]	–	Turning Touch response on or off	35, 60
[SUSTAIN]	–	Turning Sustain on or off	35, 60
[DSP(4~7)]	–	Turning DSP effects on or off	35, 60
[SLOW/FAST]	–	Setting the DSP effect variations of the selected voice part to the SLOW or FAST	35, 60
[HARMONY/ECHO]	–	Turning Harmony/Echo on or off	35, 60
[POLY/MONO]	–	Setting the selected voice part to Poly or Mono	35, 60
15 MUSIC DATABASE			
[MUSIC DATABASE]	MUSIC DATABASE	Selecting/searching/creating a Music Database	26, 76
16 ONE TOUCH SETTING			
[1], [2], [3], [4]	–	Recalling various panel settings that match the selected style	24, 73
17 REGISTRATION MEMORY			
[1] ... [8]	–	Recalling various panel settings	28
[FREEZE]	–	Turning the Freeze function on or off	28
[REGIST BANK 1~64]	–	Selecting a Registration Bank	28
18 MEMORY			
[MEMORY]	–	Memorizing various panel settings to Registration Memory/One Touch Setting	28, 73
19 VOICE			
[PIANO] ... [SYNTHESIZER]	–	Selecting the 9000Pro original preset voices	16
[PERCUSSION]	–	Selecting the 9000Pro original preset percussive voices and Drum Kits	58
[XG]	–	Selecting the preset XG voices	58
[ORGAN FLUTES]	–	Selecting/Editing the Organ Flutes	62
[CUSTOM VOICE]	–	Selecting the Custom voices	92
20 PLUG-IN VOICE			
[SLOT 1]	–	Selecting the Plug-in Board installed to Slot1	43
[SLOT 2]	–	Selecting the Plug-in Board installed to Slot2	43
[I] ~ [XI]	–	Selecting the Plug-in Voices	43
	PLUG-IN MANAGER		
	LOAD PLUG-IN CUSTOM VOICE	Loading Plug-in voice data from disk to the internal Flash ROM	66
	SAVE PLUG-IN CUSTOM VOICE	Saving Plug-in voice data in the internal Flash ROM to disk	68
	DELETE PLUG-IN CUSTOM VOICE	Deleting Plug-in voice data in the internal Flash ROM	68
	PLUG-IN SETTING	Setting various parameters related to the Plug-in Board	69
[BOARD VOICE]	–	Selecting the Board Preset/Custom Voices	43, 100
21 PART SELECT			
[LEFT], [RIGHT 1], [RIGHT 2], [RIGHT 3]	–	Selecting a part for voice assignments	57
22 PART ON/OFF			
[LEFT HOLD]	–	Turning Left Hold function on or off	61
[LEFT]	–	Turning LEFT part on or off	57
[RIGHT 1]	–	Turning RIGHT 1 part on or off	57
[RIGHT 2]	–	Turning RIGHT 2 part on or off	57
[RIGHT 3]	–	Turning RIGHT 3 part on or off	57
23 UPPER OCTAVE			
[–], [+]	–	Transposing Upper parts (RIGHT1~3) up or down by one octave	18
24 VOCAL HARMONY			
[TALK]	–	Calling up the Talk Settings related to the microphone sound	80
[DSP(8)]	–	Turning the DSP(8) effect for the microphone sound on or off	80
[V.H.(9)]	–	Turning Vocal Harmony on or off	80
[SELECT]	VOCAL HARMONY SELECT	Selecting/producing the Vocal Harmony effect	81
[MIC SETUP]	3 BAND EQ	Adjusting the gain of each band for the microphone sound	82
	NOISE GATE	Gating the input when the input signal from the microphone falls below a specified level	82
	COMPRESSOR	Holding down the output when the input signal from the microphone exceeds a specified level	82
	VOCAL HARMONY	Determining how the Vocal Harmony is controlled	82
	MIC	Determining how the microphone sound is controlled	83

Memory Structure

The 9000Pro features three different memory provisions for storing your original data: Flash ROM, RAM, and Disk.

● Flash ROM

The 9000Pro includes special Flash ROM memory. Unlike conventional ROM, Flash ROM can be overwritten — allowing you to store your own original data. The contents of Flash ROM are maintained even when the power is turned off.

● RAM

This is the conventional “internal” user memory of the 9000Pro. For sampling purposes, memory can be expanded to a maximum of 65 MB, by installing SIMM modules. Any edited data in RAM memory is lost when the power is turned off. Always store any important data in RAM to Flash ROM or save the data to disk.

● Disk

The 9000Pro also allows you to store your data to floppy disk, an optional hard disk drive, or an external (optional) SCSI device (such as a hard disk drive, or removable storage).

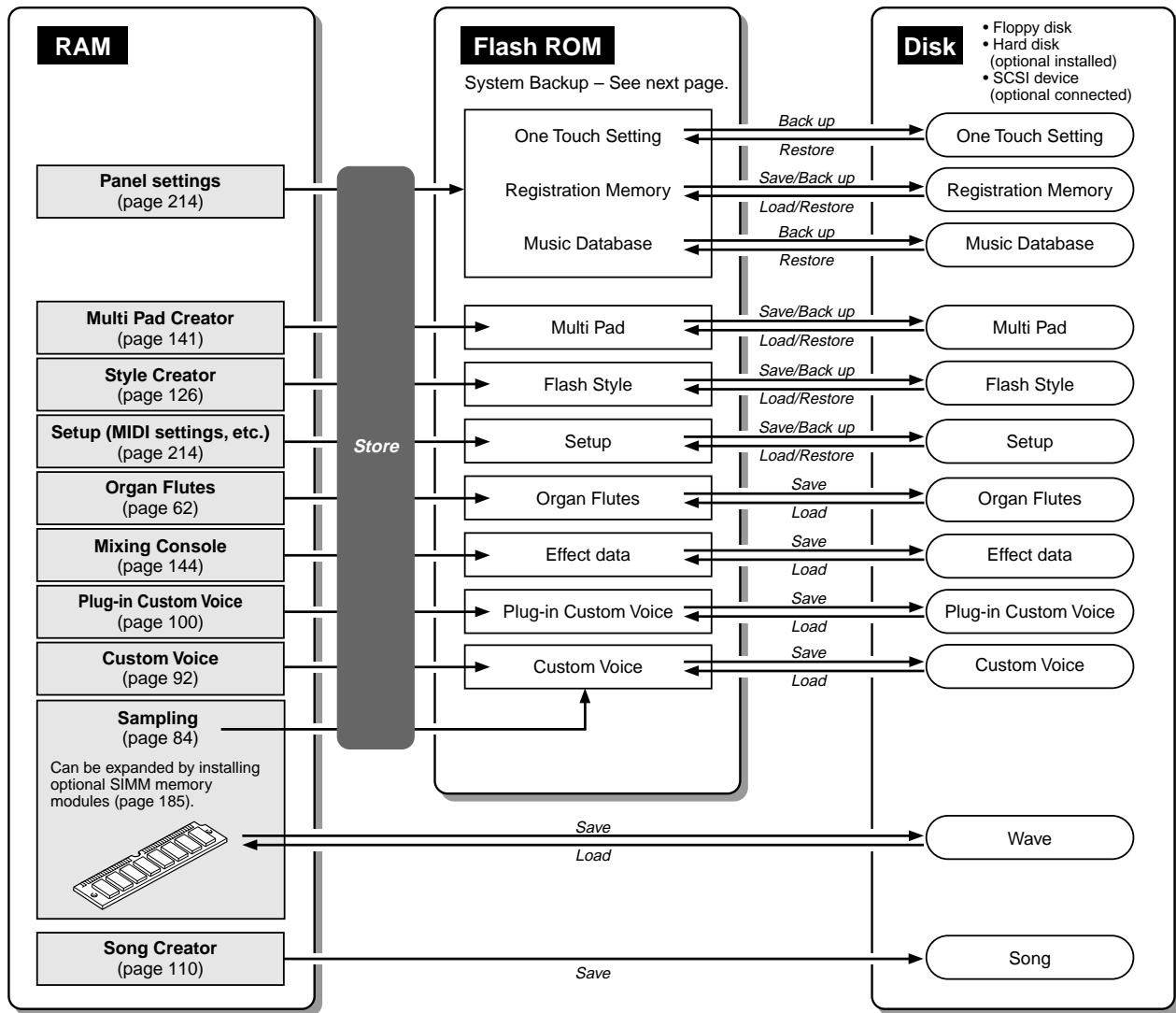

NOTE

Storing your original data to Flash ROM erases the corresponding factory data programmed to the Flash ROM (at the corresponding number locations). The following data types are affected:

- One Touch Setting
- Registration Memory
- Music Database
- Multi Pad
- Flash Style
- Setup

If you've deleted the factory-set data, you can use the Restore function (page 154) to load a copy of it from the included disks (page 6).

■ About System Backup

Important information about the 9000Pro's current settings, such as the selected style number, the Split Point setting, the fingering mode, and MIDI-related settings, can be retained in the Flash ROM. To do this, press the quarter note icon button () from the main display and follow the on-screen instructions.

For a complete list of System Backup parameters, refer to page 214.

To return the System Backup parameters to the original factory settings, simultaneously hold down the [DEMO] button and turn on the power.

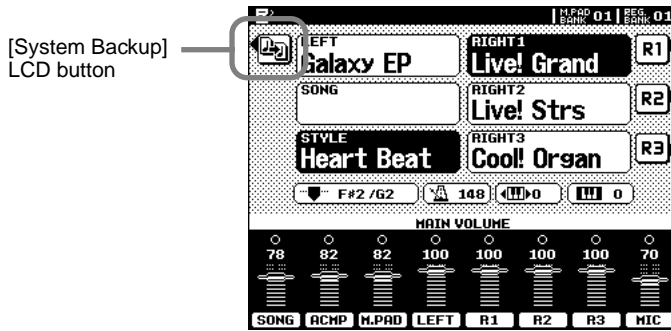

NOTE

Keep in mind the following points when using the memory devices.

- Song files can be played back without loading the data to Flash ROM or internal memory (RAM).
- Style files can be played back from Flash ROM, after loading the data from disk to Flash ROM. They can also be played directly from disk by using the Disk Direct function (page 25).
- For saving/loading any data other than style data between disk and Flash ROM, use the Disk/SCSI function (page 150). Saving/loading style data is done with the Style Manager functions (page 74).
- One Touch Setting data can be saved/loaded with the Flash style; however, it cannot be saved/loaded separately by itself.
- Music Database data can be loaded with the Disk Style data. Actually, the One Touch Setting data programmed with the Disk Style data is loaded as the Music Database. The Music Database data cannot be saved/loaded separately by itself.

■ About the Style Data

This diagram illustrates the relationship among the style data stored to different types of memory. In addition to normal memory provisions, the 9000Pro features special Flash ROM memory. Unlike conventional ROM, Flash ROM can be overwritten — allowing you to store your own original data. A number of pre-programmed styles have been loaded to the Flash ROM; these are referred to below as “Flash styles.”

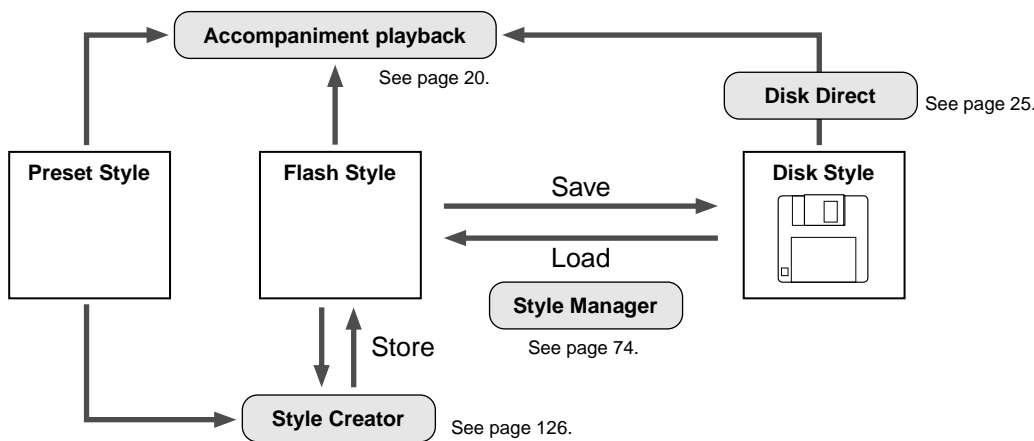

NOTE

- Storing your original style data to Flash ROM erases the factory programmed Flash style data (at the corresponding number locations). If you've deleted the factory-set data, you can use the Restore function (page 154) to load a copy of it from the included disks (page 6).

NOTE

- Flash Style data can be loaded/saved with or without its One Touch Setting setups.

Preset styles are stored to conventional ROM. These are permanent and cannot be overwritten. However, you can use these as a basis for creating your own original styles with the Style Creator (page 126). Use the Style Manager functions (page 74) to backup and organize your original style data.

Playing the disk styles can be done in two ways: 1) loading the style data to Flash ROM and playing it back as a Flash style, or 2) playing it back directly from disk, with the Disk Direct function (page 25).

■ About the Plug-in Voice Data

See page 64.

Demonstration

The 9000Pro has been programmed with a variety of demonstration songs that showcase the sophisticated capabilities of the instrument. The songs can be played individually or all together, in their normal sequence or random order.

The diagram shows the 9000Pro DEMO screen with the following callouts:

- DEMO**: A button at the top with a hand icon pointing to it.
- Select a song category**: Points to the left-side category buttons: Live!, Cool!, Sweet, and Guitar.
- Select a song category**: Points to the right-side category buttons: Live! Kit, Vocal/Flt, and Organ.
- Use this button to start/stop playback**: Points to the musical note icon button.
- Select a song**: Points to the **SONG SELECT** button.
- Turn Repeat on or off**: Points to the **REPEAT** button, which has **ON** and **OFF** indicators. Below it is the text: *When set to ON, the selected song or sequence of songs will be repeated until the STOP LCD button is pressed.*
- Select a play mode**: Points to the **MODE** button, which has **ALL**, **RANDOM**, and **SINGLE** indicators.

ALL	All demo songs are played back in sequence.
RANDOM	All demo songs are played back in random order.
SINGLE	Only the selected song is played.

Press either the **[DEMO]** button or the **[EXIT]** button to exit from the demo mode and return to the normal play mode display when you've finished playing the demo songs.

Voices

The 9000Pro has a huge selection of various musical instrument voices which you can play. Try out the different voices referring to the voice list at the end of this manual (page 192).

For basic information on selecting voices, refer to page 16 in the “Quick Guide.”

Parts: Right1, Right2, Right3 and Left

Quick Guide on page 16

The 9000Pro allows you to individually select and play up to four parts at the same time in a number of ways. A range of voices can be assigned to each part.

Keyboard Functions

As explained above, the keyboard of the 9000Pro can sound three different voices.

Here’s a short summary of the various ways of playing voices.

- **Playing a Single Voice**

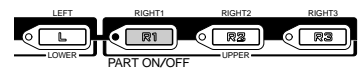

- **Playing Two Voices in a layer**

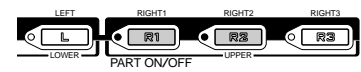

- **Playing Three Voices in a layer**

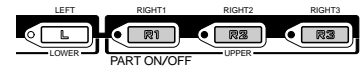
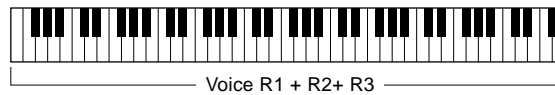

- **Playing Separate Voices with the Right and Left Hands**

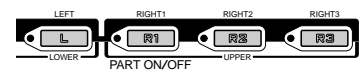
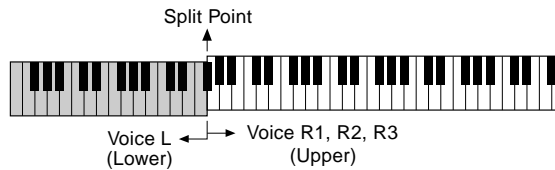

- **Playing a Chord with the Left hand – See page 20.**

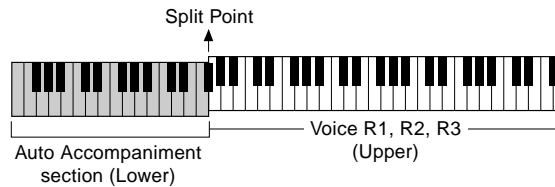

Each key has a note name; for example, the lowest (farthest left) key on the keyboard corresponds to E0 and the highest (farthest right) key to G6.

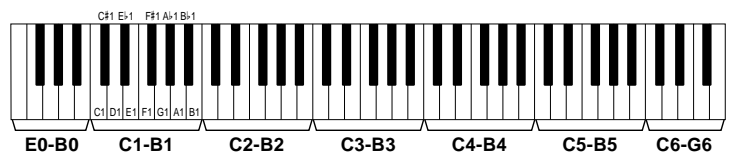

Part Selection

The desired voice can be selected for the current selected part described above.

To select the desired part, press the corresponding [PART SELECT] button.

If you want to turn only a specified part on, press the corresponding LCD button from the main display.

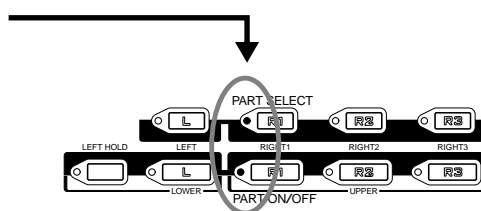
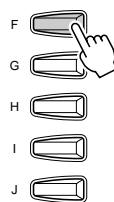

Voices

The 9000Pro actually includes several voice categories: the 9000Pro original preset voices, percussion kits, the XG voices, the Organ Flutes voices, and Custom voices. In addition, you can expand the amount of voices by installing the Plug-in Boards to the 9000Pro.

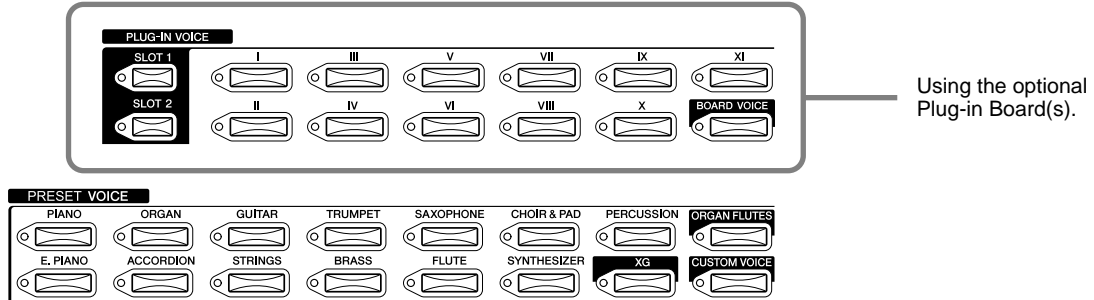

● Preset Voices

The Preset Voices are specially recorded and programmed voices exclusive to the 9000Pro.

- Keyboard Percussion When one of the Drum Kit or SFX Kit voices in the [PERCUSSION] group is selected, you can play 28 different drums and percussion instruments or SFX (sound effects) sounds on the keyboard. The drum and percussion instruments played by the various keys are marked by symbols below the keys. Some of the instruments in the different drum kit voices sound different even though they have the same name, while others are essentially the same.
See page 200 for a complete listing of the Drum Kit and SFX Kit assignments.
- XG Voices Yamaha's XG format is a major new enhancement to the GM (General MIDI) System Level 1 format. It provides a larger number of voices as well as greater expressive control and a wide range of effects. XG also ensures continued compatibility with future instruments and soft-ware.
Simultaneously hold down the desired VOICE button and press the [XG] button to call up the XG voice display of the corresponding category.
- Organ Flutes Voices See page 62.
- Custom Voices See page 92.

NOTE

- The Transpose, Tune, Sustain, Left Hold, and Modulation functions do not affect the Drum Kit or SFX Kit voices.

● Plug-in Voices

This group of special voices is available when an optional Plug-in Board is installed. See page 64 for details.

■ Maximum Polyphony

The 9000Pro features maximum polyphony of 126 notes. Since Auto Accompaniment uses a number of the available notes, the full 126 notes will not be available on the keyboard when Auto Accompaniment is used. The same applies to the Voice R2, Voice R3, Voice L, Multi Pad, and Song functions. When the maximum polyphony is exceeded, notes are played using last-note priority.

If a Plug-in Board has been installed, the polyphony of the installed board accordingly increases the available polyphony for the entire 9000Pro.

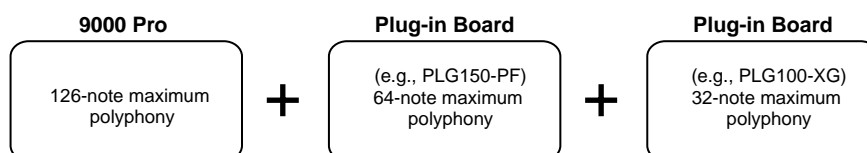

PITCH BEND Wheel & MODULATION Wheel

Use the 9000Pro **PITCH BEND** wheel to bend notes up (roll the wheel away from you) or down (roll the wheel toward you) while playing the keyboard. The **PITCH BEND** wheel is self-centering and will automatically return to normal pitch when released.

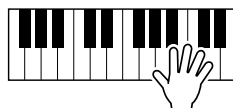
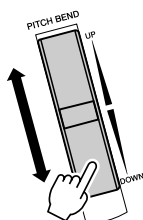

NOTE

- The maximum pitch bend range can be changed (page 145).

The Modulation function applies a vibrato effect to notes played on the keyboard. Moving the **MODULATION** wheel all the way towards yourself minimizes the depth of the effect, while rotating it away from yourself increases it. With many of the Plug-in Voices, you can control various other parameters (e.g., filter, etc.) by moving the **MODULATION WHEEL** (page 103).

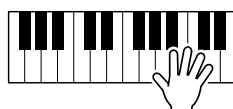
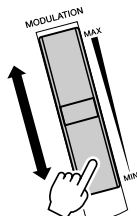

NOTE

- In order to avoid accidentally applying modulation set the depth to its minimum setting.

Voice Effects

Quick Guide
on page 35

The [VOICE EFFECT] buttons turn the corresponding effects on (indicator lit) or off (indicator out).

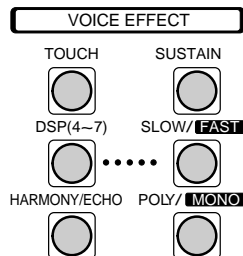

● Touch

The keyboard of the 9000Pro is equipped with a touch response feature that lets you dynamically and expressively control the level of the voices with your playing strength — just as on an acoustic instrument.



Two types of keyboard touch affect this function: Initial Touch and After Touch.

- **Initial Touch** With this function, the 9000Pro senses how strongly or softly you play the keys, and uses that playing strength to affect the sound in various ways, depending on the selected voice. This allows you to play with greater expressiveness and add effects with your playing technique.
- **After Touch** With this function, the 9000Pro senses how much pressure you apply to the keys while playing, and uses that pressure to affect the sound in various ways, depending on the selected voice. This allows you to play with greater expressiveness and add effects with your playing technique.

● Sustain

When this Sustain feature is ON, all notes played on the keyboard other than the Left part have a longer sustain.

The Sustain level can be adjusted via the Custom Voice Creator function (page 99).

● DSP (4~7) and Slow/Fast

With the digital effects built into the 9000Pro you can add ambiance and depth to your music in a variety of ways—such as adding reverb that makes you sound like you are playing in a concert hall.

- The DSP (4~7) buttons turn independent effects on or off for the Right 1 (DSP4), Right 2 (DSP5), Right 3 (DSP6) and Left (DSP7) parts.
- The [SLOW/FAST] button can switch between variations of the DSP effect. For example, this lets you change the rotating speed (slow/fast) of the rotary speaker effect.

● Harmony/Echo

See pages 35 and 164.

● Poly/Mono

This determines whether the part's voice is played monophonically (only one note at a time) or polyphonically (up to 126 notes at a time).

When this is set to "MONO," the Portamento effect can be used (depending on the selected voice) by playing legato. The degree of the Portamento effect applied differs depending on the voice. The Portamento Time can be adjusted from the Mixing Console (page 145).

NOTE

- For details about how to select a DSP effect type or set related parameters, refer to page 146.
- For details about how the effect blocks are connected, refer to the "Effect Signal Flow Chart" on page 147.

Other Keyboard-related Functions

● Left Hold

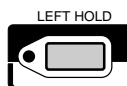

This function causes the Left part voice to be held even when the keys are released. Non-decaying voices such as strings are held continuously, while decay-type voices such as piano decay more slowly (as if the sustain pedal has been pressed).

This function is especially effective when used with the auto accompaniment. For example, if you play and release a chord in the Auto Accompaniment section of the keyboard (with the Left part on and the Left voice set to Strings), the strings part sustains, adding a natural richness to the overall accompaniment sound.

● Transpose

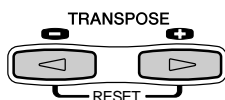

With this function, you can transpose the pitch of the 9000Pro up or down over a range of ± 2 octaves in semitone steps. Three transposing methods (Keyboard, Song, and Master) are available; select the desired method in the Function display (page 162), then use the [TRANSPOSE] buttons to change the value.

• Keyboard

The [TRANSPOSE] buttons affect the pitch of the keyboard sound, the accompaniment pitch, and the pitch of the Multi Pads for which Chord Match has been set to on. Note that the transposition is applied from the next note (or accompaniment chord) played, after one of the [TRANSPOSE] buttons has been pressed.

• Song

The [TRANSPOSE] buttons affect only the song playback.

• Master

The [TRANSPOSE] buttons affect the overall pitch of the 9000Pro.

Normal pitch (transpose value of "0") can be recalled at any time by pressing both the [◀] and [▶] buttons simultaneously.

The transposition can be adjusted from the Mixing Console display (page 145).

● Octave Change

Refer to the Quick Guide on page 18.

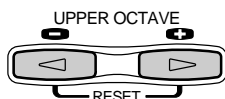

In addition to the many organ voices in the [ORGAN] voice category, the 9000Pro has an ORGAN FLUTES voice which can be assigned to the currently selected part and edited by pressing the VOICE [ORGAN FLUTES] button.

Basic Procedure

Press the [ORGAN FLUTES] button.

Adjust the parameters.

Select this to call up the Preset Organ Flutes display.

Select this to call up the display of various settings.

Adjust the Footage.

Select this to call up the display of the Volume/Attack settings.

Use button [1] to adjust the 16' or 8' footage. You can select the desired footage (16' or 8') with the [E] LCD button.

You can select the number to call up your original settings.

Call up the Store display.

Select the number to be stored and store your settings.

NOTE

- The Organ Flutes settings are applied to the currently selected part. Custom settings can be stored as a User Organ Flutes voice, but the current part cannot itself be stored. For example, you can edit the Organ Flutes settings from the R1 part and store them, then reselect those settings from the R3 part.

NOTE

- The echo, tremolo, and trill effects set via the Harmony/Echo function (page 164) may not affect the Organ Flutes sound as expected.

Parameters

Organ Type	This parameter specifies the type of organ tone generation to be simulated: Sine or Vintage.
Rotary SP Speed	The Rotary SP Speed LCD button alternately switches between the slow and fast rotary speaker speeds when a rotary speaker effect is selected for the Organ Flutes (see "DSP Type" below), and the VOICE EFFECT [DSP(4-7)] button is turned on (the Rotary SP Speed LCD button has the same effect as the VOICE EFFECT [DSP SLOW/FAST] button).
Vibrato On/Off	This LCD button alternately turns the vibrato effect for the Organ Flutes voice ON or OFF.

Vibrato Depth	Can be set to any of three levels via the Vibrato Depth LCD button. The button sequentially selects a depth of "1", "2", or "3".	
Footage	The footage settings determine the basic sound of the organ flutes. The term "footage" is a reference to the sound generation of traditional pipe organs, in which the sound is produced by pipes of different lengths (in feet). The longer the pipe, the lower the pitch of the sound. Hence, the 16' setting determines the lowest pitched component of the voice, while the 1' setting determines the highest pitched component. The higher the value of the setting, the greater the volume of the corresponding footage. Mixing various volumes of the footages lets you create your own distinctive organ sounds.	
Volume	Adjusts the overall volume of the Organ Flutes. The longer the graphic bar, the greater the volume.	
Mode	The MODE control selects between two modes: FIRST and EACH. In the FIRST mode, attack is applied only to the first notes played and held simultaneously; while the first notes are held, any subsequently played notes have no attack applied. In the EACH mode, attack is applied equally to all notes.	
Attack	The ATTACK controls adjust the attack sound of the ORGAN FLUTE voice. The 4', 2 2/3' and 2' controls increase or reduce the amount of attack sound at the corresponding footages. The longer the graphic bar the greater the attack sound.	
Length	The LENGTH control affects the attack portion of the sound producing a longer or shorter decay immediately after the initial attack. The longer the graphic bar the longer the decay.	
Response	The Response control affects both the attack and sustain portion of the sound, increasing or decreasing the response time of the initial swell and release, based on the FOOTAGE controls. The higher the value the slower the swell and release.	
Reverb Depth Chorus Depth DSP on/off DSP Depth	For details about the digital effects, see page 145.	
Vibrato Speed	Determines the speed of the vibrato effect controlled by the Vibrato On/Off and Vibrato Depth above.	
DSP Type	Determines the DSP effect type to be applied to the Organ Flutes voice. Normally this will be one of the six available Rotary Speaker effects. If any other type of effect is selected the Rotary SP Speed LCD button in the main ORGAN VOICE editing display will not control rotary speaker speed. Instead, it will have the same effect as the VOICE EFFECT [SLOW/FAST] button.	
Slow/Fast	Slow/Fast	Determines whether the DSP variation (Slow/Fast) will be set to Slow or Fast when the Organ Flutes voice is selected (when the Voice Set function is ON — page 163).
	Value	Sets the DSP variation (Slow/Fast) parameter value (e.g., "LFO Freq" for a Rotary Speaker effect) when the DSP variation (Fast) is turned on.
EQ Low EQ High	The EQ parameters determine the Frequency and Gain of the Low and High EQ bands.	

By installing an optional Plug-in Board to the 9000Pro, you can gain instant access to a whole new assortment of amazing voices.

Instructions on selecting and playing the Plug-in Voices are given in the Quick Guide on page 42. In the following section, you'll learn more about how the Plug-in Voices are used and managed, and how they fit into the 9000Pro's system.

Guidelines

Memory Structure of the Plug-in Voices

You learned about the Plug-in Voices and Board Voices in the Quick Guide on page 43. In the illustration below, we'll go into greater detail about how they are used. This shows various aspects of the Plug-in Manager function, which is used to manage (save/load) Plug-in Voice data on disk.

The relationship between the devices (Disk, Flash ROM, and Plug-in Board) may seem a little complex; however, the basic principles are easy to grasp. One important thing you should remember is that you can work with and manage the voice data from the 9000Pro itself or from a connected computer. From the 9000Pro, you can edit and manage the voice data in Flash ROM created via the Plug-in Custom Voice Creator (page 100). From a computer, you can create and edit voice data directly on the Board. Also keep in mind that any data in RAM memory is not saved until you specifically save it to disk.

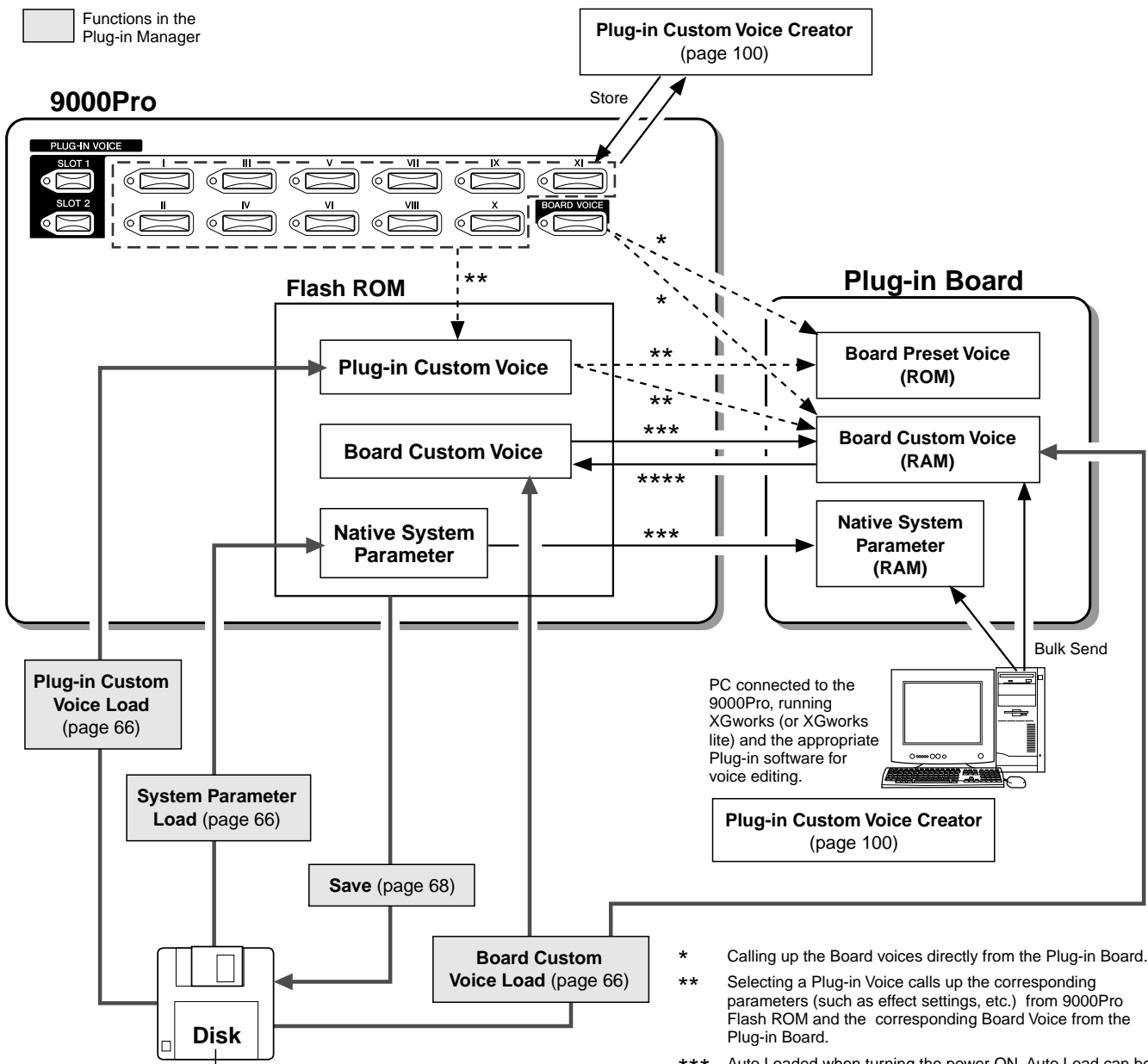

All of the parameter settings for one board can be saved to a single file, which can then be loaded to the 9000Pro.

- * Calling up the Board voices directly from the Plug-in Board.
- ** Selecting a Plug-in Voice calls up the corresponding parameters (such as effect settings, etc.) from 9000Pro Flash ROM and the corresponding Board Voice from the Plug-in Board.
- *** Auto Loaded when turning the power ON. Auto Load can be set via Plug-in setting (page 69)
- **** Board Custom Voice Backup in the Plug-in Custom Voice Creator function (page 108)

● **Board Custom Voices**

As mentioned above, the Board voices are the internal voices of the Plug-in Board, and provide the basic material for the Plug-in voices as played from the 9000Pro. Among the Board voices are a special set of voices — Board Custom voices — which can be edited from a computer connected to the 9000Pro. Each Plug-in Board comes with its own special editing software (to be used as a plug-in with XGworks), and the Board Custom voices are edited with this software. However, if you want to keep any edits that you make to the voices, you must save the data to the 9000Pro with the Board Custom Voice Backup function, since any data in the RAM memory on the board is lost as soon as the power is turned off.

● **Board Preset Voices**

These Board Voices are pre-programmed to the Plug-in Board and cannot be edited from a computer connected to the 9000Pro.

● **Plug-in Custom Voices**

Before the Board voices can be selected and played from the 9000Pro, they are “converted” to Plug-in voices. By using the Custom Voice Creator function, you can edit the various parameters of the Plug-in voices and create your own original voices.

■ **About the Plug-in Boards**

Plug-in Boards give you an enormous amount of additional sonic flexibility and power. When installed, they work seamlessly and transparently within the system of the 9000Pro — meaning that you can use their sounds and functions just as if they were built right into the 9000Pro at the factory!

The boards that are available for and can be installed to the 9000Pro are described below. These boards are not simply a source of more voices, they are full-featured tone generators in their own right, and they let you not only upgrade the 9000Pro system by adding more polyphony for example, but they also let enhance and edit the sounds with a variety of parameters. Three types of boards are available: Single Part, Multi Part, and Effect. The Single Part and Multi Part boards can be used with the 9000Pro. Please note, however, that Effect Plug-in Boards (e.g., PLG-100VH) cannot be used with the 9000Pro.

● **Single Part Plug-in Boards**

Single Part Plug-in Boards let you add a completely different synthesizer or tone generator and play its voices by using a single part of the 9000Pro. Keep in mind that the Single Part boards can only be used for one part (R1 - R3, L, Song Creator) at a time (see pages 42 and 125).

- Analog Physical Modeling Plug-in Board (PLG150-AN)

Using Analog Physical Modeling (AN) synthesis, the very latest digital technology is used to accurately reproduce the sound of analog synthesizers.

- Piano Plug-in Board (PLG150-PF)

A massive 16MB of waveform memory is dedicated to the reproduction of piano sounds. This board offers 136 stereo sounds, including a number of acoustic and electric pianos, and up to 64-note polyphony.

- Advanced DX/TX Plug-in Board (PLG100-DX, PLG150-DX)

The sounds of the DX7 are available on this Plug-in Board. Unlike PCM-based tone generators, this board uses the powerful FM Synthesis system — the same as found on DX-series synthesizers — for extraordinarily versatile and dynamic sound shaping potential. Sounds are compatible with those of the DX7, and the board can even receive DX7 data via MIDI bulk dump.

- Virtual Acoustic Plug-in Board (PLG100-VL, PLG150-VL)

With Virtual Acoustic (VA) synthesis, the sounds of real instruments are modeled (simulated) in real time, giving a degree of realism that cannot be achieved using conventional PCM-based synthesis techniques. When playing these sounds using an optional MIDI Wind Controller (WX5), you can even capture some of the physical feel of woodwind instruments.

NOTE

- Additional Plug-in Boards will be available in the future.

NOTE

- The Board Custom Voices (RAM) described on page 64 are not available in some Plug-in Boards (e.g., PLG150-PF, PLG100-VL, PLG100-DX).

NOTE

- Included with each Plug-in Board is a floppy disk featuring special demo songs. You can play these demo songs on the 9000Pro (XG Plug-in System format only) using the Song Player function. Refer to the Owner's Manual of your particular Plug-in Board for details on the demo songs.

● **Multi-Part Plug-in Board**

Multi-Part Plug-in Boards let you expand the voice polyphony of the 9000Pro by giving you a full 16 independent instrumental parts. This type of board allows you to use the maximum polyphony of the 9000Pro for your keyboard performance. For example, this is especially useful when playing the Organ Flutes voices, which require many notes of polyphony. (See HINT on page 69.)

Please note that the voices of the Multi Part boards cannot be played from the 9000Pro's keyboard.

- XG Plug-in Board (PLG100-XG)

This Plug-in Board is a 16-part XG sound generator. You can play back XG/GM song files using the rich variety of sounds and effects on this board.

Plug-in Manager

This function lets you manage the Plug-in Voice related parameters as disk files.

The following three types of parameters (described in the illustration on page 64) are available:

Plug-in Custom Voices	These can be edited via the Plug-in Custom Voice Creator function (page 102).
Native System Parameters	These can be edited via the Native System Parameter Edit function (page 105). Available parameters vary according to the installed board.
Board Custom Voices	These can be edited via your computer. See pages 100 and 106 for details.

Basic Procedure

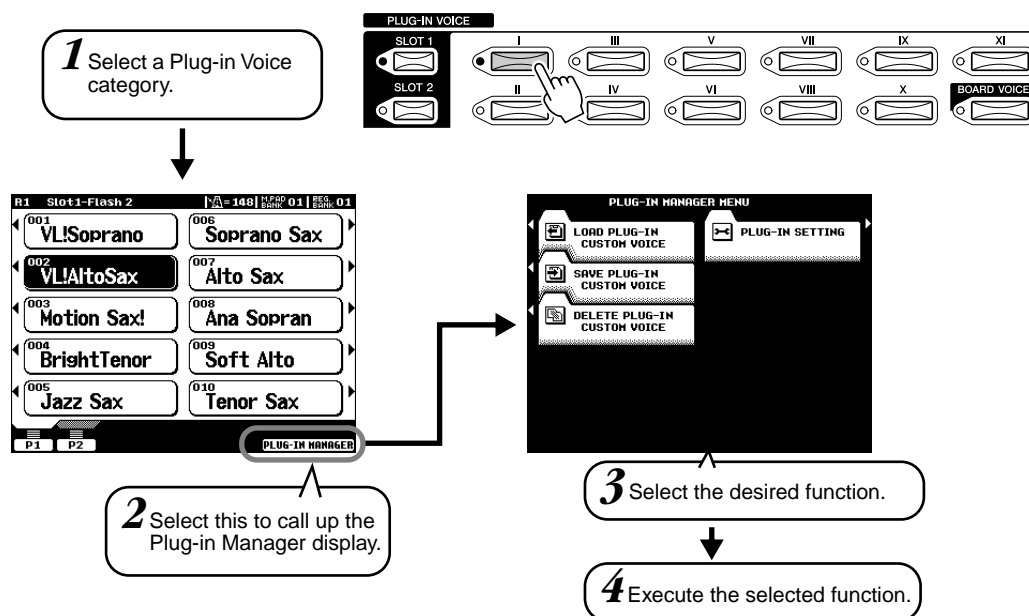

The operations for each function corresponding to step #4 are covered in the following explanations.

Load Plug-in Custom Voice

Quick Guide Step#3 on page 42

The explanations here apply to step #4 above.

All

The three types of parameters explained in the chart above can all be loaded together. Use the instructions here for loading in step #3 of the Quick Guide on page 42.

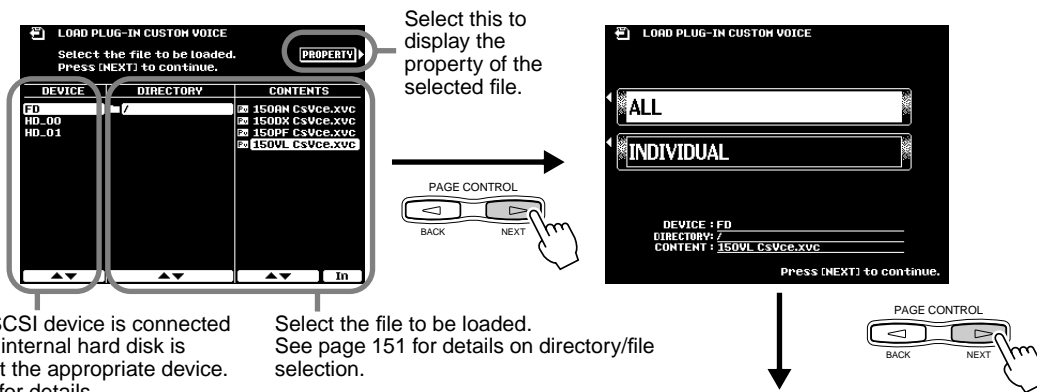

If an optional SCSI device is connected or the optional internal hard disk is installed, select the appropriate device. See page 150 for details.

Select the file to be loaded. See page 151 for details on directory/file selection.

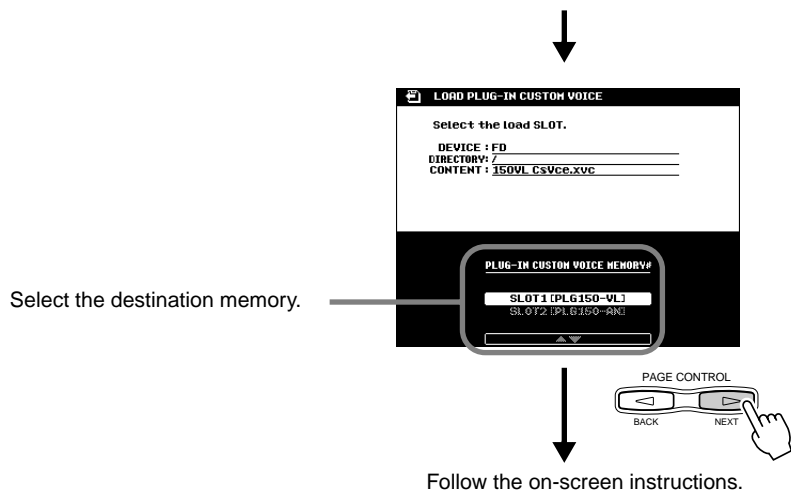

● Individual

This method lets you individually load the three types of parameters explained in the chart on page 66.

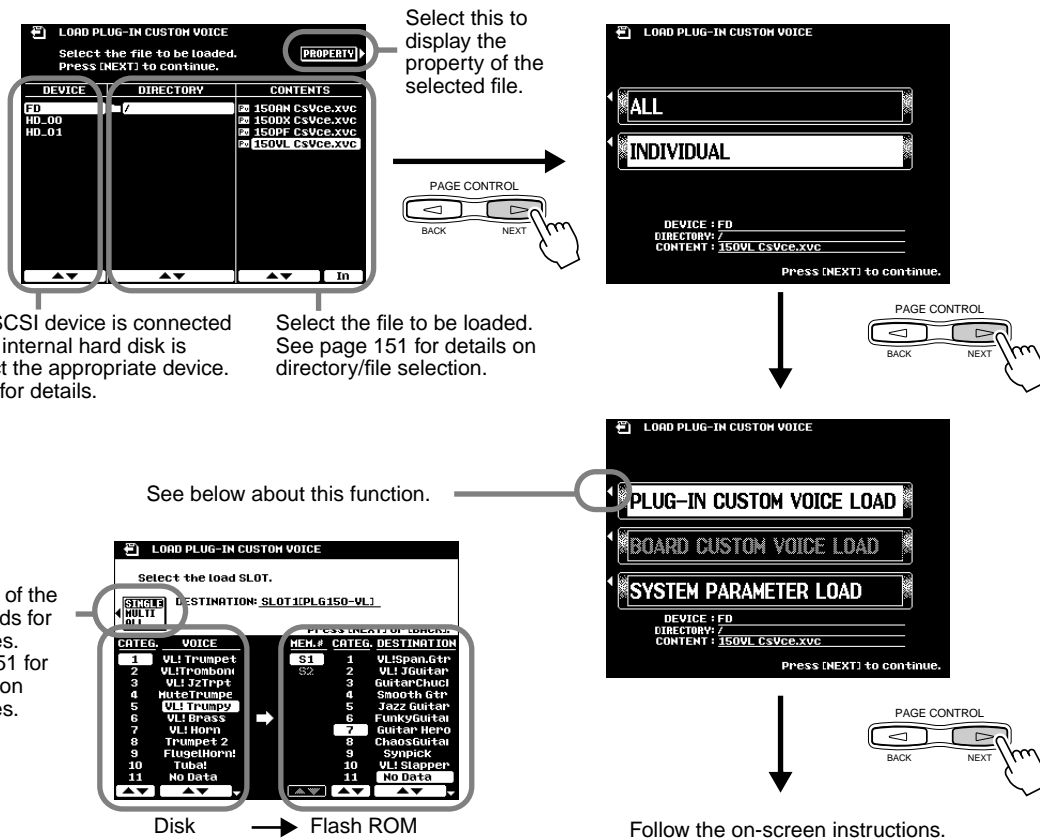

LOAD PLUG-IN CUSTOM VOICE

Select the load SLOT.

DESTINATION: SLOT1(PLG150-VL1)

CATEG.	VOICE	MEM.#	CATEG.	DESTINATION
1	VL1 Trumpet	1	VLISpan.Gtr	
2	VL1 Trombone	2	VL1 Guitar	
3	VL1 TrpT	3	GuitarChuel	
4	MuteTrumpe	4	Smooth Gtr	
5	VL1 Trumpy	5	Jazz Guitar	
6	VL1 Brass	6	FunkGuitar	
7	VL1 Horn	7	Guitar Hepo	
8	Trumpet 2	8	ChaosGuitar	
9	FlugelHorn	9	Synpick	
10	Tuba	10	VL1 Slapper	
11	No Data	11	No Data	

■ Save

This allows you to copy Plug-in Voice data from Flash ROM to disk. The explanations here apply to step #4 on page 66.

NOTE

- The Plug-in Voice related data in Flash ROM (page 64) is maintained even if the Plug-in Board has been removed. Make sure to execute the save operation if you have important data in Flash ROM that you wish to keep.

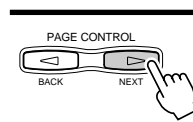
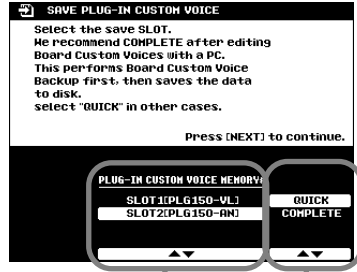

Follow the on-screen instructions.

Select the appropriate Slot number corresponding to the board which applies to the voice parameters you wish to save to disk.

Select QUICK or COMPLETE. See below about these two types of saving methods.

Quick Save	Saves all the Plug-in Custom Voice, Native System parameters, and the Board Custom Voice data in Flash ROM to a disk.
Complete Save	Used for backing up the Board Custom Voice data from the Plug-in board to Flash ROM and saves all the Plug-in Custom Voice, Native System parameters, and the Board Custom Voice data in Flash ROM to a disk.

■ Delete

This allows you to delete Plug-in Voice data in Flash ROM. The explanations here apply to step #4 on page 66.

CAUTION

- You can clear all the Plug-in Voice parameters in Flash ROM by using this button. After executing this operation, the voice of the selected slot cannot be used. Turn the power OFF and then turn the power ON to use this board with default settings

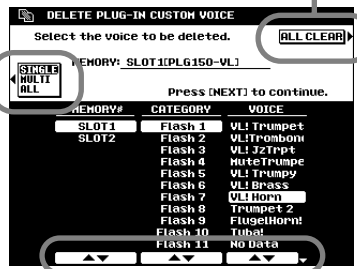

Choose one of the three methods for selecting files. See page 151 for instructions on selecting files.

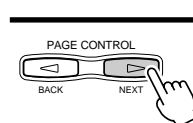

Follow the on-screen instructions.

Select the voice to be deleted.

■ Plug-in Setting

This lets you set other useful settings for the Plug-in Board. The explanations here apply to step #4 on page 66.

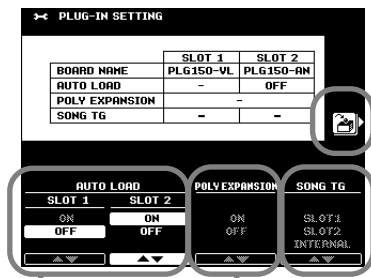

You can store the settings in this display to Flash ROM by using this button.

This function is for Multi Part Plug-in Boards (e.g., PLG150-XG), and lets you select the tone generator for XG disk song playback. When "SLOT 1" or "SLOT 2" is selected, the installed Plug-in Board is used as the tone generator for the XG disk song playback. When "INTERNAL" is selected, the 9000Pro internal tone generator is used. See the HINT below for information on how to use this function effectively.

Set Auto Load to ON or OFF. See the illustration on page 64.

This parameter is available when the same (or same type) of Plug-in Boards (e.g., the PLG100-DX and the PLG150-DX) are installed in the two slots. When the appropriate boards are installed and this is set to on, the two boards effectively function as one, and are assigned to a single part (R1, R2, R3, or L), effectively doubling the total polyphony. When this is set to ON, you can select the Plug-in voice only via the [SLOT1] button. Please note that the [SLOT2] button cannot be used.

NOTE

- If you have installed a PLG150 Board to SLOT 1 and a PLG100 Board to SLOT 2 (or, in other words, installed a higher level board of the same type to SLOT 1), and have set POLY EXPANSION to ON, you may experience certain problems when playing the voices. See page 109.

HINT

Using the SONG TG (Tone Generator) Function

- For example, when set to SLOT 1:

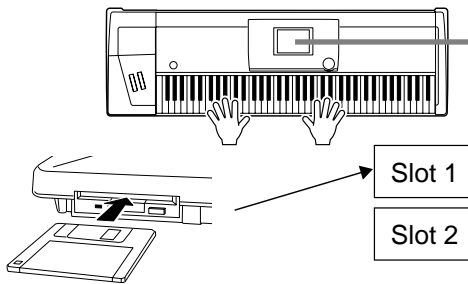

If you are playing back XG song data with the 9000Pro, you can use an XG Plug-in Board installed to Slot 1 as a dedicated tone generator — freeing up the polyphony of the internal tone generator to be used exclusively for your keyboard performance. This is especially convenient when playing an Organ Flutes voice, which requires many notes of polyphony.

- For example, when set to INTERNAL:

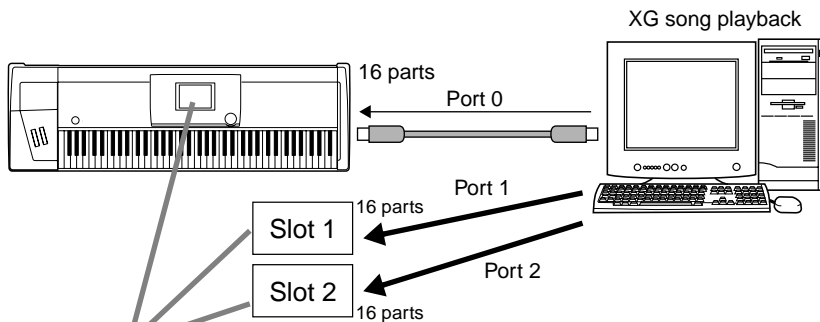

In this setup, you can play back up to 48 different parts from sequencing software on a computer, using the three tone generators of the 9000Pro: the internal tone generator, and two installed XG Plug-in Boards. To play back the song with the settings above, make the appropriate Thru Port settings (page 173) to 1-8 or OFF, so that the 9000Pro will properly recognize the MIDI Port data.

The auto accompaniment feature puts a full backing band at your fingertips. To use it, all you have to do is play the chords with your left hand as you perform and the selected accompaniment style matching your music will automatically play along, instantly following the chords you play. With auto accompaniment, even a solo performer can enjoy playing with the backing of an entire band or orchestra.

This section explains some important functions of the auto accompaniment that are not covered in the “Quick Guide.” For basic information on playing the auto accompaniment, refer to page 20 in the “Quick Guide.”

Chord Fingerings

Quick Guide
Step#5 on page 21

The way in which chords are played or indicated with your left hand (on the left side of the keyboard from the Split Point) is referred to as “fingering.” There are 7 types of fingerings as described below.

Refer to page 159 for instructions on setting the split point and fingering mode.

● Single Finger

Single Finger accompaniment makes it simple to produce beautifully orchestrated accompaniment using major, seventh, minor and minor-seventh chords by pressing a minimum number of keys on the Auto Accompaniment section of the keyboard. The abbreviated chord fingerings described below are used:

- For a major chord, press the root key only.



- For a seventh chord, simultaneously press the root key and a white key to its left.



- For a minor chord, simultaneously press the root key and a black key to its left.



- For a minor-seventh chord, simultaneously press the root key and both a white and black key to its left.



● Multi Finger

The Multi Finger mode automatically detects Single Finger or Fingered chord fingerings, so you can use either type of fingering without having to switch fingering modes.

● Fingered

This mode lets you finger your own chords on the auto accompaniment section of the keyboard, while the 9000Pro supplies appropriately orchestrated rhythm, bass, and chord accompaniment in the selected style. The Fingered mode recognizes the various chord types listed on the next page.

● Fingered Pro

This mode is basically the same as Fingered, with the exception that more than three notes must be played to indicate the chords. Playing the root note and its octave produces accompaniment based only on the root.

● On Bass

This mode accepts the same fingerings as the Fingered mode, but the lowest note played in the Auto Accompaniment section of the keyboard is used as the bass note, allowing you to play “on bass” chords (in the Fingered mode the root of the chord is always used as the bass note).

● On Bass Pro

This mode is basically the same as On Bass, with the exception that more than three notes must be played to indicate the chords. Playing the root note and its octave produces accompaniment based only on the root.

● Full Keyboard

When this advanced auto-accompaniment mode is engaged the 9000Pro will automatically create appropriate accompaniment while you play just about anything, anywhere on the keyboard using both hands. You don't have to worry about specifying the accompaniment chords. Although the Full Keyboard mode is designed to work with many songs, some arrangements may not be suitable for use with this feature. Try playing a few simple songs in the Full Keyboard mode to get a feel for its capabilities.

The 9000Pro recognizes chords you play in the Auto Accompaniment section of keyboard and produces appropriate chords, even if auto accompaniment is off (as long as the Left part is set to on). Chords are recognized according to the Fingered mode, even if the mode is actually set to another mode. This setting is especially effective when used with the Vocal Harmony or the Harmony/Echo.

Chord Types Recognized in the Fingered Mode

● Example for “C” chords

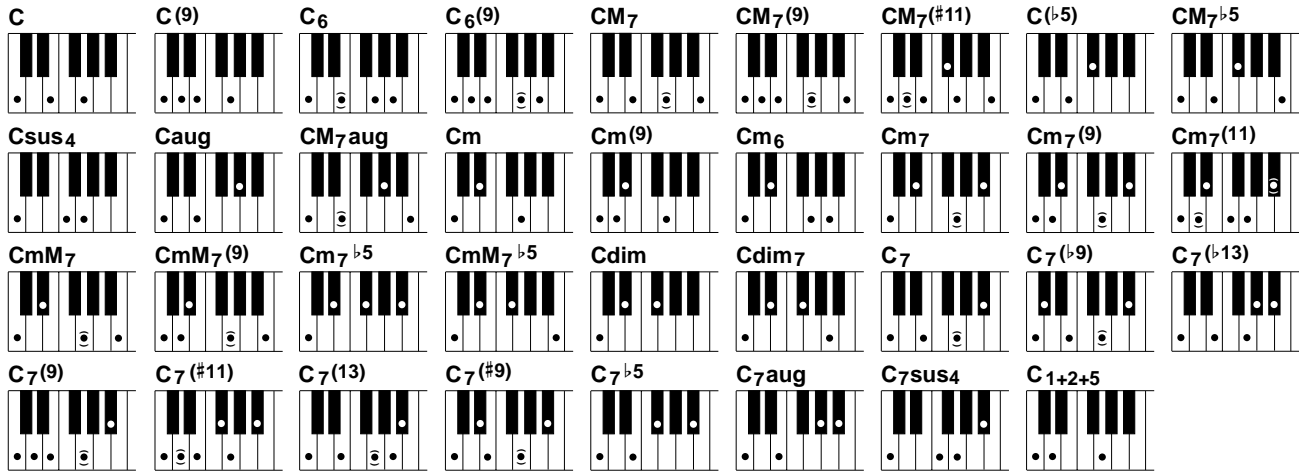

Chord Name [Abbreviation]	Normal Voicing	Display for root “C”
Major [M]	1 - 3 - 5	C
Add ninth [(9)]	1 - 2 - 3 - 5	C(9)
Sixth [6]	1 - (3) - 5 - 6	C6
Sixth ninth [6(9)]	1 - 2 - 3 - (5) - 6	C6(9)
Major seventh [M7]	1 - 3 - (5) - 7	CM7
Major seventh ninth [M7(9)]	1 - 2 - 3 - (5) - 7	CM7(9)
Major seventh add sharp eleventh [M7(#11)]	1 - (2) - 3 - #4 - 5 - 7 or 1 - 2 - 3 - #4 - (5) - 7	CM7#11
Flatted fifth [(b5)]	1 - 3 - b5	C(b5)
Major seventh flatted fifth [M7b5]	1 - 3 - b5 - 7	CM7b5
Suspended fourth [sus4]	1 - 4 - 5	Csus4
Augmented [aug]	1 - 3 - #5	Caug
Major seventh augmented [M7aug]	1 - (3) - #5 - 7	CM7aug
Minor [m]	1 - b3 - 5	Cm
Minor add ninth [m(9)]	1 - 2 - b3 - 5	Cm(9)
Minor sixth [m6]	1 - b3 - 5 - 6	Cm6
Minor seventh [m7]	1 - b3 - (5) - b7	Cm7
Minor seventh ninth [m7(9)]	1 - 2 - b3 - (5) - b7	Cm7(9)
Minor seventh eleventh [m7(11)]	1 - (2) - b3 - 4 - 5 - (b7)	Cm7_11
Minor major seventh [mM7]	1 - b3 - (5) - 7	CmM7
Minor major seventh ninth [mM7(9)]	1 - 2 - b3 - (5) - 7	CmM7_9
Minor seventh flatted fifth [m7b5]	1 - b3 - b5 - b7	Cm7b5
Minor major seventh flatted fifth [mM7b5]	1 - b3 - b5 - 7	CmM7b5
Diminished [dim]	1 - b3 - b5	Cdim
Diminished seventh [dim7]	1 - b3 - b5 - 6	Cdim7
Seventh [7]	1 - 3 - (5) - b7 or 1 - (3) - 5 - b7	C7
Seventh flatted ninth [7(b9)]	1 - b2 - 3 - (5) - b7	C7(b9)
Seventh add flatted thirteenth [7(b13)]	1 - 3 - 5 - b6 - b7	C7b13
Seventh ninth [7(9)]	1 - 2 - 3 - (5) - b7	C7(9)
Seventh add sharp eleventh [7(#11)]	1 - (2) - 3 - #4 - 5 - b7 or 1 - 2 - 3 - #4 - (5) - b7	C7#11
Seventh add thirteenth [7(13)]	1 - 3 - (5) - 6 - b7	C7(13)
Seventh sharp ninth [7(#9)]	1 - #2 - 3 - (5) - b7	C7(#9)
Seventh flatted fifth [7b5]	1 - 3 - b5 - b7	C7b5
Seventh augmented [7aug]	1 - 3 - #5 - b7	C7aug
Seventh suspended fourth [7sus4]	1 - 4 - 5 - b7	C7sus4
One plus two plus five [1+2+5]	1 - 2 - 5	C1+2+5

NOTE

- Notes in parentheses can be omitted.
- If you play any three adjacent keys (including black keys), the chord sound will be canceled and only the rhythm instruments will continue playing (Chord Cancel function).
- Playing a single key or two same root keys in the adjacent octaves produces accompaniment based only on the root.
- A perfect fifth (1 + 5) produces accompaniment based only on the root and fifth which can be used with both major and minor chords.
- The chord fingerings listed are all in “root” position, but other inversions can be used — with the following exceptions:
m7, m7b5, 6, m6, sus4, aug, dim7, 7b5, 6(9), m7_11, 1+2+5.
- Inversion of the 7sus4 chord is not recognized if the 5th is omitted.
- The auto accompaniment will sometimes not change when related chords are played in sequence (e.g. some minor chords followed by the minor seventh).
- Two-note fingerings will produce a chord based on the previously played chord.

Fade-ins and Fade-outs

The [FADE IN/OUT] button can be used to produce smooth fade-ins and fade-outs when starting and stopping the accompaniment.

To produce a fade-in/out :

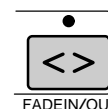

- ▶ **1 Press the [FADE IN/OUT] button so that its indicator lights.**
- ▶ **2 Start the accompaniment**
The sound will gradually fade in. The [FADE IN/OUT] indicator will flash during the fade-in, and then go out when full volume has been reached.
- ▶ **3 Press the [FADE IN/OUT] button so that its indicator lights.**
The indicator will flash during the fade out, then the accompaniment will stop when the fade-out is complete.

Tempo Control

Each style of the 9000Pro has been programmed with a default or standard tempo; however, this can be changed to any value between 32 and 280 beats per minute by using the data dial (see page 44) when the TEMPO lamp is engaged. This can be done either before the accompaniment is started or while it is playing.

When you select a different style while the accompaniment is not playing, the “default” tempo for that style is also selected. If the accompaniment is playing, the same tempo is maintained even if you select a different style.

■ Tap Tempo

This useful function lets you press the [TAP TEMPO] button to tap out the tempo and automatically start the accompaniment at that tapped speed. Simply tap (press/release) the button (four times for a 4/4 time signature), and the accompaniment starts automatically at the tempo you tapped. The tempo can also be changed during playback by tapping the button twice at the desired tempo.

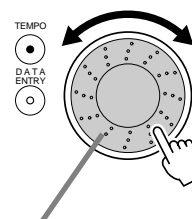

Rotating the data dial to the right (clockwise) increases the value, while rotating it to the left (counterclockwise) decreases it.

● When a 4-beat style is selected

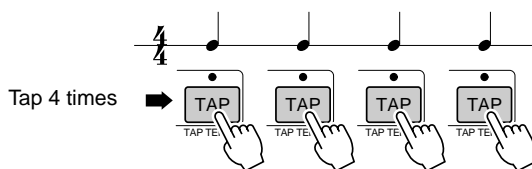

*When a 3-beat style is selected, tap 3 times.

Synchro Stop

When the Synchro Stop function is engaged, accompaniment playback will stop completely when all keys in the auto-accompaniment section of the keyboard are released. Accompaniment playback will start again as soon as a chord is played. The BEAT indicators will flash while the accompaniment is stopped. For basic information on playing the auto accompaniment, refer to page 20 in the “Quick Guide.”

NOTE

- Synchro Stop cannot be set to on when the fingering mode is set to Full Keyboard or the auto accompaniment on the panel is set to off.

- ▶ **1** Turn **AUTO ACCOMPANIMENT** on.
- ▶ **2** Turn **SYNC STOP** on.
SYNC START is automatically set to on when SYNC STOP is turned on.
- ▶ **3** As soon as you play a chord with your left hand, the auto accompaniment starts.

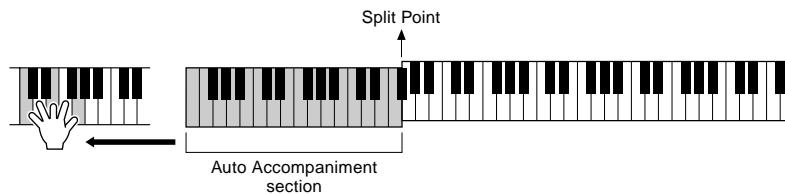
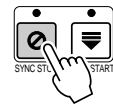

- ▶ **4** The auto accompaniment stops when you release your left hand from the keys.
- ▶ **5** Playing a chord with your left hand automatically restarts the auto accompaniment.
- ▶ **6** Stop the auto accompaniment.

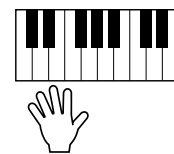

One Touch Setting

For basic information on using the One Touch Setting feature, refer to page 24 in the “Quick Guide.” This section covers how to create your own One Touch Setting setups (4 setups per style). For a list of One Touch Setting setup parameters, refer to page 214.

- ▶ **1** Select a style.
- ▶ **2** Set up the panel controls as required.
- ▶ **3** Press the **[MEMORY]** button and press one of the **[ONE TOUCH SETTING]** buttons: [1] through [4].

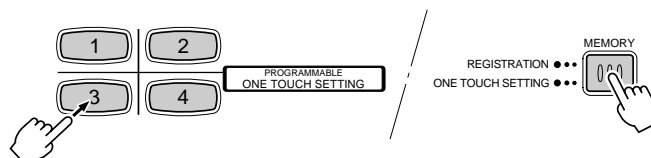

Style Manager

The 9000Pro styles are divided into two groups : Preset styles and Flash styles.
Flash styles pre-recorded to Flash styles I through VIII can be replaced by the desired data with the Style Manager function.

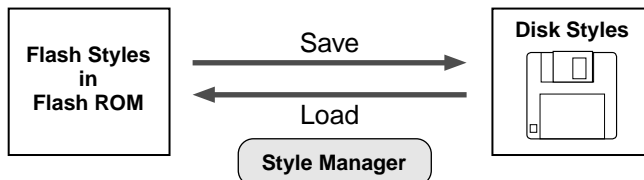

NOTE

Since all Flash style data is stored to Flash ROM, any data in the selected Flash style location will be erased and replaced by your new settings. This includes the factory programmed Flash style data (Flash styles I through VIII). If you've deleted the factory-set data, you can use the Restore function (page 154) to load a copy of it from the included disks (page 6). For details about Flash ROM, refer to "Memory Structure" on page 54.

Basic Procedure

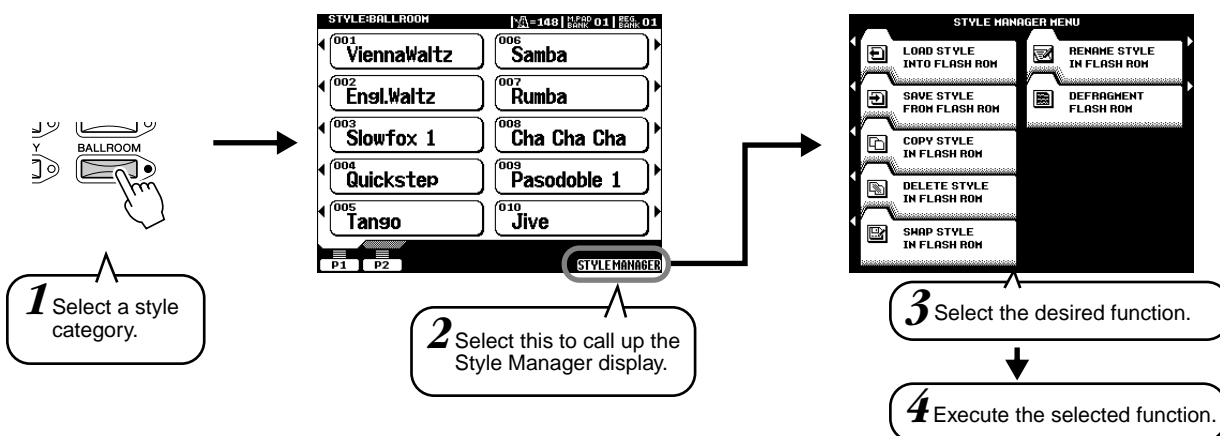

The operations for each function corresponding to step #4 are covered in the following explanations.

Load Style into Flash ROM

This allows you to load style data from disk to Flash ROM.

Choose one of the three methods for selecting files (see page 151).

Select this to display the property of the selected file.

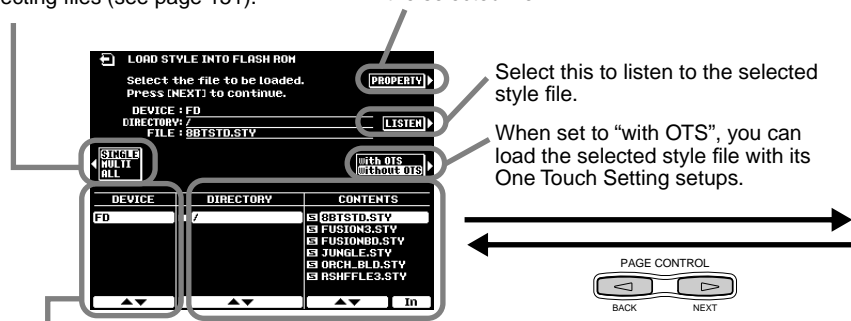

If an optional SCSI device is connected or the optional internal hard disk is installed, select the appropriate device. See page 150 for details.

See page 151 for details on directory/file selection.

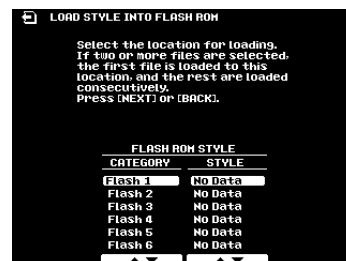

You can select the desired location in Flash ROM as the destination. See "CAUTION" on page 151.

■ Save Style from Flash ROM

This allows you to save style data from Flash ROM to disk.

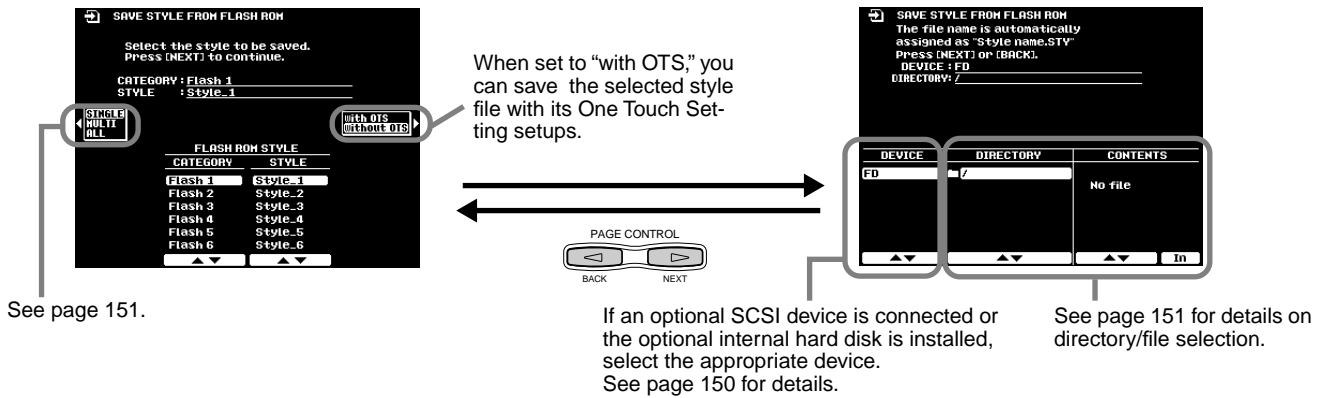

■ Copy Style in Flash ROM

This allows you to copy style data to a different category/number in Flash ROM. Follow the on-screen instructions.

■ Delete Style in Flash ROM

This allows you to delete style data in Flash ROM. Follow the on-screen instructions.

■ Swap Style in Flash ROM

This allows you to exchange the data between files in different categories/numbers. Follow the on-screen instructions.

■ Rename Style in Flash ROM

This allows you to rename the style file name. Follow the on-screen instructions. Name entry is described on page 46.

■ Defragment Flash ROM

If you've used the Style Manager for a while, and/or have loaded and manipulated a number of styles, the Flash ROM may have become "fragmented" (meaning that normally contiguous files have been broken up into several fragments). Defragmenting the Flash ROM increases the contiguous empty space on the disk, allowing you to more effectively use the remaining memory capacity. To defragment the Flash ROM, follow the on-screen instructions.

NOTE

- The 9000Pro can load files containing Registration Memory data created on the PSR-8000, without having to convert them. However, please note that the five Flash styles listed in the left column below should not be deleted or replaced with different styles, since they are used to substitute for the corresponding PSR-8000 styles listed in the right column.

9000Pro Flash Style			PSR-8000	
Category	Number	Name	Category	Name
II	4	Analog Ballad	16 beat	Analog Pop
III	1	6/8 Trance	Disco	Synth Boogie
IV	1	Bebop	Swing & Jazz	Bebop
X	5	Lovely Shuffle	R&B	Pop Shuffle 1, 2
XIII	6	Musette	March & Waltz	Musette

For basic information on using the Music Database feature, refer to page 26 in the “Quick Guide.” This section covers how to create your own Music Database setups. For a list of Music Database setup parameters, refer to page 214.

Creating the Music Database

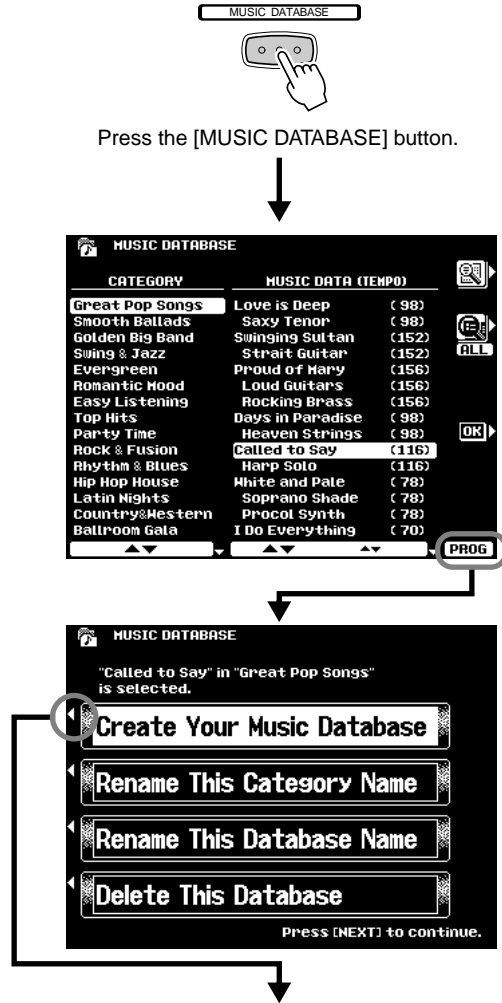

Create the Music Database by following the on-screen instructions.

NOTE

Since all Music Database data is stored to Flash ROM, any data in the selected Music Database location will be erased and replaced by your new settings. This includes all of the factory programmed preset setups. If you've deleted the factory-set data, you can use the Restore function (page 154) to load a copy of it from the included disks (page 6).

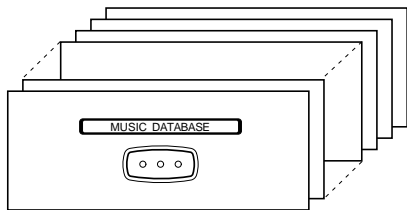

Music Database
setups in Flash ROM
All preset setups can be edited.

For details about Flash ROM, refer to “Memory Structure” on page 54.

This section explains two important functions of the Multi Pads that are not covered in the “Quick Guide.” For basic information on using the Multi Pads, refer to page 34 in the “Quick Guide.”

Turning Chord Match and Repeat On/Off

STOP M.PAD BANK 1-60

Press the [+]/[-] buttons simultaneously.

MULTIPAD

MULTI PAD BANK VIEW [NA-148] [55] 01

001 Live! Tom	006 ArabicPerc 1
002 Live! Crash	007 ArabicPerc 2
003 Live! Kit 1	008 Latin Perc 1
004 Live! Kit 2	009 Latin Perc 2
005 Live! Kit 3	010 Dance Kit

Select "REPEAT" or "CHORD MATCH:"

MULTI PAD BANK VIEW

CURRENT BANK: 01 Live! Tom

REPEAT/CHORD MATCH

	PAD1	PAD2	PAD3	PAD4
1 REPEAT				
2 CHORD MATCH		✓		✓

Select this to store the settings. (Refer to the “CAUTION” note below.)

BANK

01 Live! Tom

02 Live! Crash

03 Live! Kit 1

04 Live! Kit 2

REPEAT

ON	ON	ON	ON
OFF	OFF	OFF	OFF

Turn Repeat of each pad On or Off. Use the same operation to turn Chord Match On/Off.

Select a Bank.

Repeat

Unless the Repeat function is on for the selected pad, playback will end automatically as soon as the end of the phrase is reached. A phrase can be stopped while it is playing by pressing the **MULTI PAD [STOP]** button.

Chord Match

If a Multi Pad is played while Auto Accompaniment is playing and the Chord Match function for that pad is ON, the phrase will be automatically re-harmonized to match the accompaniment chords.

NOTE

Since all Multi Pad data is stored to Flash ROM, all of the factory programmed Multi Pad banks will be replaced by your new settings. If you've deleted the factory-set data, you can use the Restore function (page 154) to load a copy of it from the included disks (page 6).

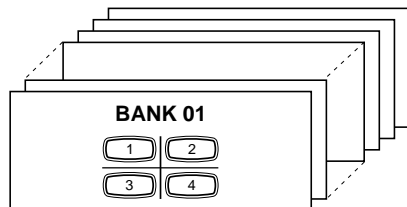

Multi Pad banks
60 banks in Flash ROM
All banks can be replaced by the new created pad data.

For details about Flash ROM, refer to “Memory Structure” on page 54.

CAUTION

The Repeat and Chord Match settings for the Multi Pads are stored together in a group of 58 banks. For this reason, you should be careful when making edits and storing your edits, since all 58 banks will be overwritten with the new data.

NOTE

- Bank #59 (factory preset) of the Multi Pads can be used to send various MIDI messages. This convenient feature lets you control the following MIDI functions of an external device by simply pressing the appropriate Multi Pad.

- Pad 1 All Note Off
- Pad 2 Reset All Controllers
- Pad 3 Start(FA)
- Pad 4 Stop(FC)

- These MIDI messages are output via the MIDI OUT B terminal and are unaffected by the MIDI Transmit settings (page 175).

- Bank #60 (factory preset) of the Multi Pads can be used to call up various settings of the Scale Tuning feature (page 158). This lets you change the tuning of the individual notes by simply pressing the appropriate Multi Pad.

The 9000Pro Song mode allows song data to be played back from a floppy disk, an optional hard disk or an optional SCSI device.

This section explains some important functions of song playback that are not covered in the “Quick Guide.” For basic information on playing songs, refer to page 30 in the “Quick Guide.”

Selecting a Song

The 9000Pro allows you to play back songs from disk, as described in the operation steps below. Keep in mind that steps #2 and #3 are identical to the other disk file selection operations for the instrument.

1 Insert the floppy disk (containing the files shown below) into the floppy disk drive, and press the [SONG I] button.

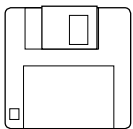

- 01arabe2.mid
- 02sheher.mid
- 03puck.mid
- 04edud15.mid
- 05sylphe.mid
- 06praul6.mid
- 07saraba.mid
- 08dancin.mid
- 09vals12.mid
- 10paspie.mid
- Classic01
 - Classic01a
 - Classic01b
 - 01lente.mid
 - 02g_walk.mid
- Classic02
 - Classic02a
 - Classic02b
- Classic03
 - Classic03a
 - Classic03b

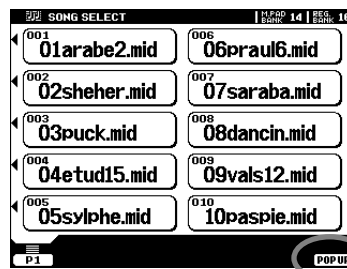

2 This selects the “pop up” page shown below.

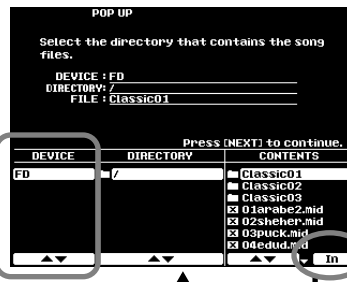

If an optional hard disk has been installed or an optional SCSI device has been connected, the appropriate device must be selected here.

You can return to the next highest level by pressing the [IN] LCD button while the cursor is located at .

3

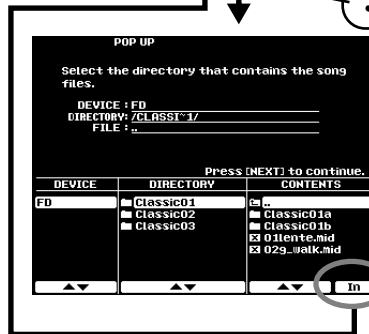

These steps are identical to all other 9000Pro disk file selection operations (for example, see page 151).

NOTE

- In the file selection display, a maximum 250 file or directory names can be displayed. If the number of files or directories exceeds 250, the 251st and beyond (according to alphabetical order) are not shown.

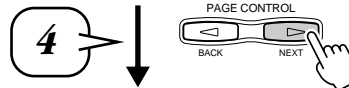

5 Select the desired song.

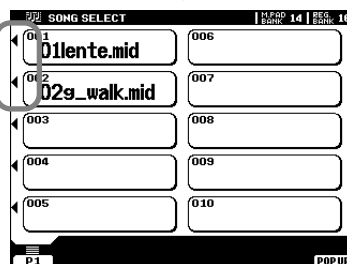

Other Functions: Viewing the Lyrics and Fast Forward/Reverse

Select this to call up the Lyrics display.

Select this during playback to move rapidly forward through the song.

Select this during playback to move rapidly backward through the song.

This button lets you pause playback and then start again from the same point in the song.

Song Setup

This function determines certain playback settings for song data other than note on/off (for example, lyrics).

- When set to SEARCH ON, the 9000Pro reads the lyric data when the song is selected, allowing the lyrics to be displayed immediately after you press the [START/STOP] button.
 - When set to SEARCH OFF, the 9000Pro reads the lyric data after playback is started. This may result in a slight delay before the lyrics are displayed.
 - When set to NEVER DISPLAY, the lyrics will not be shown in the LCD display during playback.
- When the Ultra Quick Start function here is set to ON, the 9000Pro reads all initial non-note data of the song at the highest possible speed, then automatically slows down to the appropriate tempo at the first note of the song. This allows you to start actual song playback as quickly as possible, with a minimum pause for reading of data.
- Press this button to save the microphone and Vocal Harmony settings to the selected song. See below for details.

■ About Vocal Harmony/Microphone Settings for a Song

The Vocal Harmony and Microphone settings can be stored as Song Setup data. When using the Vocal Harmony function with a song, this convenient feature lets you store all relevant Vocal Harmony and Microphone settings with the song, so that they are automatically called up the next time you select the song. The actual settings that can be stored are listed below.

- Vocal Harmony type and parameter settings..... Page 81
- Vocal Harmony Vocoder track settings (keyboard and song) Page 82
- Effect type and parameter settings (for the microphone sound)..... Page 146
- Volume, Pan, Reverb depth, Chorus depth and DSP (8) depth (for the microphone sound)..... Page 145

HINT

- You can use the metronome function during playback. See page 166 for details.

This unique feature incorporates advanced voice-processing technology to automatically produce vocal harmony based on a single lead vocal. An extensive selection of preset Vocal Harmony “types” are provided, each functioning in one of three main “modes” which determine how the harmony notes are applied. In addition to straightforward harmony, the 9000Pro Vocal Harmony feature can change the pitch and timbre of the harmony and/or lead vocal sound to effectively change the apparent gender of the voice. So, for example, if you are a male singer you can have a two-part female vocal backup (the Vocal Harmony feature can add up to two harmony notes to the main lead voice). A full range of parameters is provided to allow detailed editing to produce precisely the type of vocal harmony sound you need.

Setting Up

■ Setting up the microphone

NOTE

Please note the following points :

- A standard dynamic microphone with an impedance of about 250 ohms is recommended. (The 9000Pro does not support phantom-powered condenser microphones.)
- The Yamaha MZ106s microphone is recommended for use with the 9000Pro.
- The level of the microphone sound may vary considerably according to the type of microphone used.
- Placing a microphone which is connected to the 9000Pro too close to those of an external sound system connected to the 9000Pro can cause feedback. Adjust the microphone position and the INPUT VOLUME level or MASTER VOLUME control level if necessary, so that feedback does not occur.

■ Using the “LINE” setting

Normally, since you will be using a microphone, you may never need to use the “LINE” setting. However, this may come in handy if you want to use a pre-recorded source (on CD or cassette tape) with the vocal harmony feature. (For best results, the source should be a single vocal only; any other singers and instruments in the mix could produce unexpected or undesired results.)

CAUTION

- Never use the “MIC” setting with a line level signal (CD player, cassette deck, etc.). Doing this could damage the 9000Pro and its input functions.

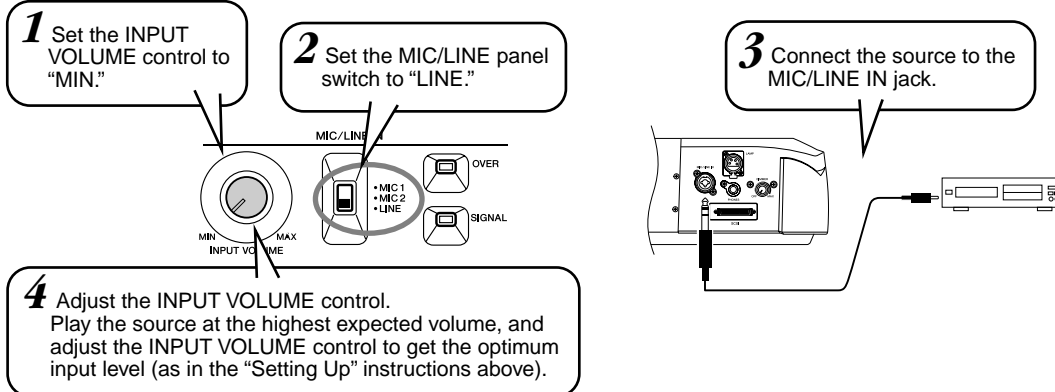

IMPORTANT

- Since the MIC/LINE IN jack is highly sensitive, it may pick up and produce noise when nothing is connected. To avoid this, **always set the INPUT VOLUME to minimum** when nothing is connected to the MIC/LINE IN jack.

Applying the Vocal Harmony Effect

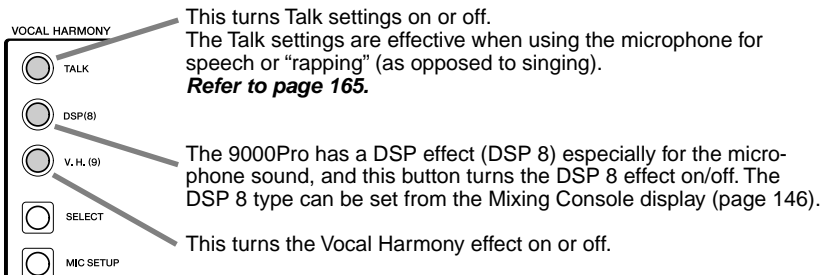

NOTE

- If you experience distorted or out-of-tune sound from the Vocal Harmony feature, your vocal microphone may be picking up extraneous sounds (other than your voice) — the Auto Accompaniment sound from the 9000Pro, for example. In particular, bass sounds can cause mistracking of the Vocal Harmony feature. The solution to this problem is to ensure that as little extraneous sound as possible is picked up by your vocal microphone:
- Sing as closely to the microphone as possible.
- Use a uni-directional microphone.
- Turn down the MASTER VOLUME, ACMP volume or SONG volume control.

Selecting/Producing the Vocal Harmony effect

Basic Procedure

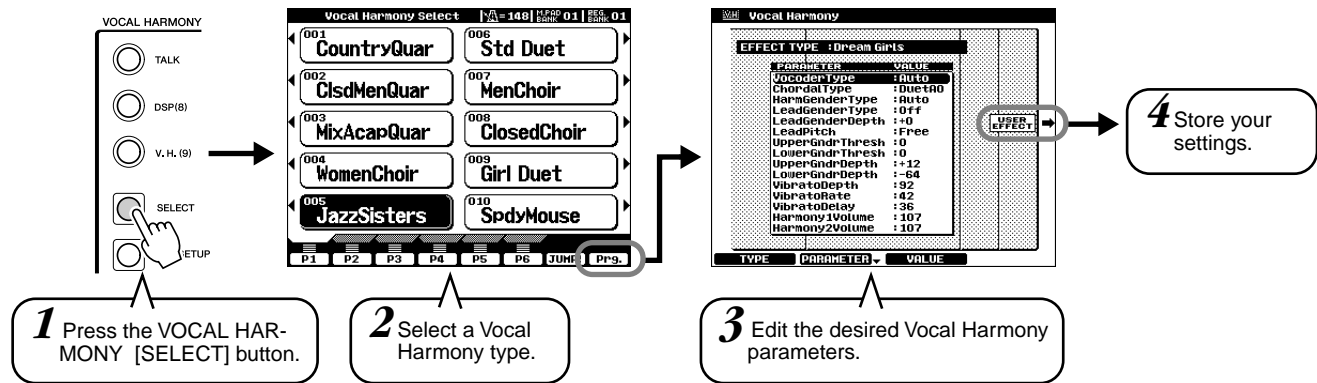

Vocal Harmony Parameters

Chordal Type/Vocoder Type	Determines how the harmony notes are applied.
Harmony Gender Type	Can be set to "Off" or "Auto". When "Auto", the gender of the harmony sound is changed automatically.
Lead Gender Type	Determines whether and how the gender of the lead vocal sound (i.e., the direct microphone sound) will be changed. When "Off" no gender change occurs. When "Unison", "Male" or "Female" is selected the corresponding gender change is applied to the lead vocal. (In this case the number of harmony notes which can be produced in addition to the lead vocal is reduced to one.)
Lead Gender Depth	Adjusts the degree of lead vocal gender change produced when one of the Lead Gender Types (above) is selected.
Lead Pitch Correction	When "Correct" is selected the pitch of the lead vocal is shifted in precise semitone steps. This parameter is only effective when one of the Lead Gender Types is selected.
Auto Upper Gender Threshold	Gender change will occur when the harmony pitch reaches or exceeds the specified number of semitones above the lead vocal pitch.
Auto Lower Gender Threshold	Gender change will occur when the harmony pitch reaches or exceeds the specified number of semitones below the lead vocal pitch.
Upper Gender Depth	Adjusts the degree of gender change applied to harmony notes higher than the Auto Upper Gender Threshold.
Lower Gender Depth	Adjusts the degree of gender change applied to harmony notes lower than the Auto Lower Gender Threshold.
Vibrato Depth	Sets the depth of vibrato applied to the harmony sound. Also affects the lead vocal sound if a Lead Gender Type is selected.
Vibrato Rate	Sets the speed of the vibrato effect.
Vibrato Delay	Specifies the length of the delay before the vibrato effect begins when a note is produced.
Harmony1 Volume	Sets the volume of the first harmony note.
Harmony2 Volume	Sets the volume of the second harmony note.
Harmony3 Volume	Sets the volume of the third harmony note.
Harmony1 Pan	Specifies the stereo (pan) position of the first harmony note. When "Random" is selected the stereo position of the sound will change randomly whenever the keyboard is played.
Harmony2 Pan	Specifies the stereo (pan) position of the second harmony note. When "Random" is selected the stereo position of the sound will change randomly whenever the keyboard is played.
Harmony3 Pan	Specifies the stereo (pan) position of the third harmony note. When "Random" is selected the stereo position of the sound will change randomly whenever the keyboard is played.
Harmony1 Detune	Detunes the first harmony note by the specified number of cents.
Harmony2 Detune	Detunes the second harmony note by the specified number of cents.
Harmony3 Detune	Detunes the third harmony note by the specified number of cents.
Pitch to Note	When "ON" the lead vocal sound "plays" the 9000Pro tone generator system. (However, dynamic changes in the vocal sound do not affect the volume of the tone generator.)
Pitch to Note Part	Determines which of the 9000Pro parts will be controlled by the lead vocal when the Pitch to Note parameter is "ON".

Changing the Vocal Harmony/Microphone Settings

Basic Procedure

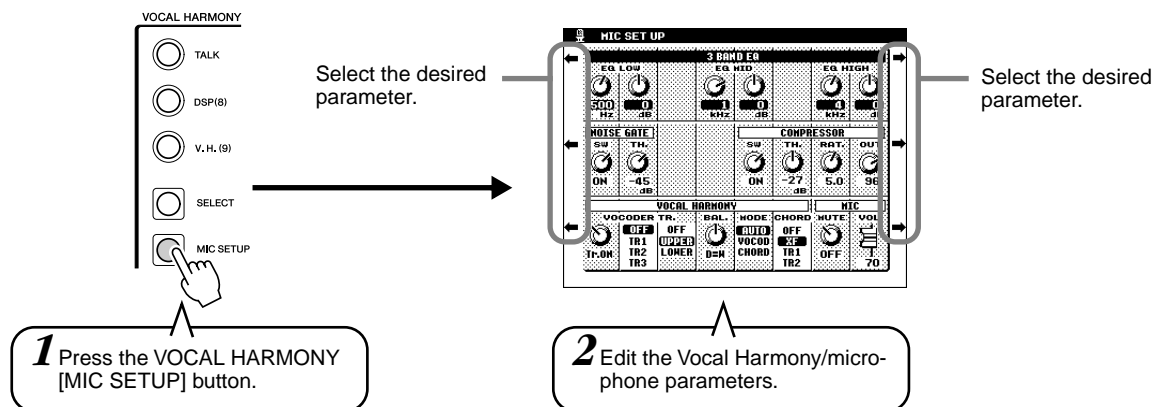

● 3-Band Equalizer

Usually an equalizer is used to correct the sound output from amps or speakers to match the special character of the room. The sound is divided into several frequency bands, allowing you to correct the sound by raising or lowering the level for each band.

The 9000Pro features a high grade three-band digital equalizer function for the microphone sound.

- Hz.....Adjusts the center frequency of the corresponding band.
- dBBoosts (“+” values) or cuts (“-” values) the corresponding band by up to 12 dB.

● Noise Gate

This effect mutes the input signal when the input from the microphone falls below a specified level. This effectively cuts off extraneous noise, allowing the desired signal (vocal, etc.) to pass.

- SW“SW” is the abbreviation of Switch. This turns Noise Gate on or off.
- TH“TH” is the abbreviation of Threshold. This adjusts the input level at which the gate begins to open.

● Compressor

This effect holds down the output when the input signal from the microphone exceeds a specified level. This is useful when recording a signal with widely varying dynamics. It effectively “compresses” the signal, making soft parts louder and loud parts softer.

- SW“SW” is the abbreviation of Switch. This turns Compressor on or off.
- TH“TH” is the abbreviation of Threshold. This adjusts the input level at which compression begins to be applied.
- RAT“RAT” is the abbreviation of Ratio. This adjusts the compression ratio.
- OUTAdjusts the output level from the speaker.

● Vocal Harmony

The following parameters determines how the harmony is controlled.

- VOCODER Track...The Vocal Harmony effect is controlled by the notes. This parameter lets you determine which notes (from the keyboard and/or song data) will control the harmony.

Data dial icon

When set to “MUTE,” the track selected below is muted (turned off) during keyboard performance or song playback.

Keyboard

- OFF Keyboard control over harmony is turned off.
- UPPER Notes played to the right of the split point control the harmony.
- LOWER Notes played to the left of the split point control the harmony.

Song (from disk or external MIDI sequencer)

- OFF Song data control over harmony is turned off.
- TR1-TR16 When playing back a song from disk or external MIDI sequencer, the note data recorded to the assigned song track controls the harmony.

- **Balance** This lets you set the balance between the lead and Vocal Harmony. Raising this value increases the volume of the Vocal Harmony and decreases that of the lead vocal. If it is set to the maximum value of 127, you will hear only the Vocal Harmony from the external speakers; if it is set to 0, only the lead vocal will be heard.
- **Mode** All of the Vocal Harmony types fall into one of three modes which produce harmony in different ways. The harmony effect is dependent on the selected Vocal Harmony Mode and Track, and this parameter determines how the harmony is applied to your voice. The three modes are described below.
 - **VOCODER** The harmony notes are determined by the notes you play on the keyboard (VOICE R1, R2, R3, L) and/or song data which includes Vocal Harmony tracks.
 - **CHORDAL** During accompaniment playback, chords played in the auto accompaniment section of the keyboard control the harmony. During song playback, chords contained in song data control the harmony. (Not available if the song does not contain any chord data.)
 - **AUTO** The harmony notes are produced in either Vocoder or Chordal mode according to the current performance method.
- **Chord** The following parameters specify the song data which will be used for chord detection.
 - **OFF** Chords are not detected.
 - **XF** Chords of XF format are detected.
 - **TR1-TR16** Chords are detected from note data in the specified song track.

● **Microphone**

The following parameters determine how the microphone sound is controlled.

- **Mute** When set to OFF, the microphone sound is turned off.
- **Volume** Adjusts the volume of the microphone sound.

This function lets you record your own sounds via a microphone or line source to be played from the keyboard.

During use, sampled sounds are kept in the internal wave RAM memory. The 9000Pro comes with a 1-megabyte wave memory which can be expanded up to a maximum of 65 megabytes by installing optional SIMM memory modules — see page 185 for details. Sampled wave data can be saved to floppy or hard disk. Wave files in standard WAV or AIFF format produced using other equipment can also be used by the 9000Pro.

Setting up

Use the same operation as in “Vocal Harmony” on pages 32 and 80.

The notes and cautions contained on page 80 in “Vocal Harmony” also apply to Sampling.

Guidelines for Sampling

■ What is sampling ?

Technically, sampling is making a digital recording of a sound. The sound could be your voice or an acoustic instrument (taken from a microphone), or a recorded sound (from a CD or cassette player). Once it is recorded, the resulting “sample” can be played at various pitches from a keyboard.

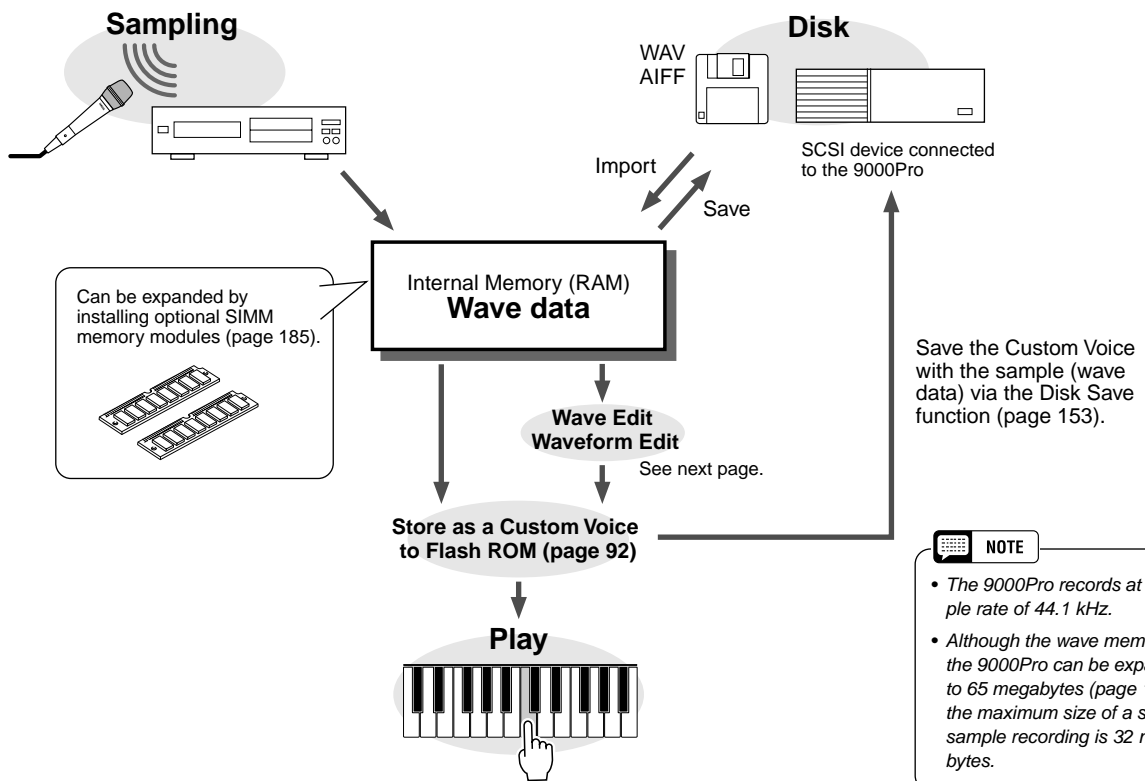

■ Auto Trigger Level

Actually, the 9000Pro does not start sampling immediately when the [START] LCD button is pressed (in step #11 on page 41). Once the [START] LCD button is pressed, the 9000Pro waits for a signal of a suitable level (set by the trigger level). When it hears such a signal, it starts sampling.

The Trigger Level can be set in step #10 on page 40.

The higher the trigger level, the louder the signal must be to start (trigger) sampling.

To better understand how trigger level works, let's look at a specific example — sampling of the phrase “a one and a two.”

In this phrase, “one” and “two” are louder than the other words.

Since the first “a” is lower than the trigger level, the 9000Pro doesn't actually start sampling until the word “one.” If you want the phrase to be sampled from the first word, the trigger level should be set lower.

With this new trigger level setting, the entire phrase will be sampled. Be careful, however, not to set the trigger level too low, or else sampling may start from some accidental or extraneous sound (such as breathing noises, touching the microphone, etc.).

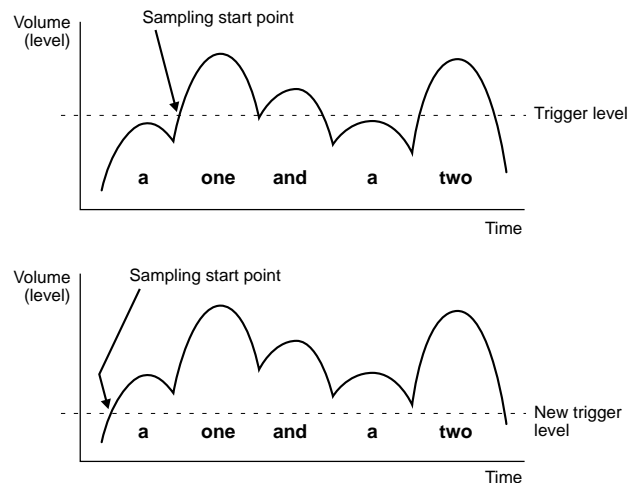

■ Waves & Waveforms

The terms “wave” and “waveform” have distinct meanings in 9000Pro sampling terminology, as follows:

● Wave

A “wave” is the raw audio data created whenever you sample a new sound or import a WAV or AIFF format wave file. The 9000Pro WAVE EDIT mode includes functions which allow you to edit this basic data: e.g. resampling to change the sampling frequency, trimming and looping, normalization for maximum level and minimum noise, etc.

● Waveform

All 9000Pro waves are contained in a “waveform”, which is basically a set of parameters which define the keyboard range over which the wave or waves it contains will play. A waveform can contain one or more waves, and waves can be shared by more than one waveform. Waves in a waveform can be assigned to different ranges of the keyboard, but they cannot be layered (i.e. they will not sound simultaneously when a single key is played). The 9000Pro WAVEFORM EDIT mode lets you add or delete waves from a waveform, and assign the waves to different keyboard ranges.

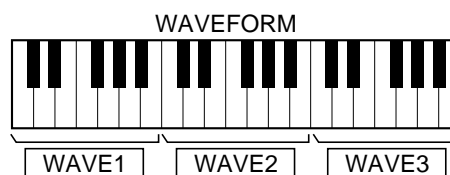
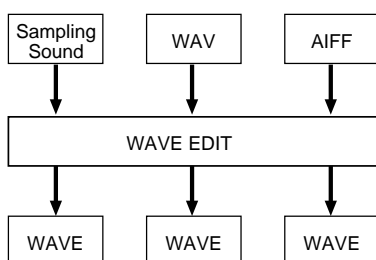

Basic Procedure

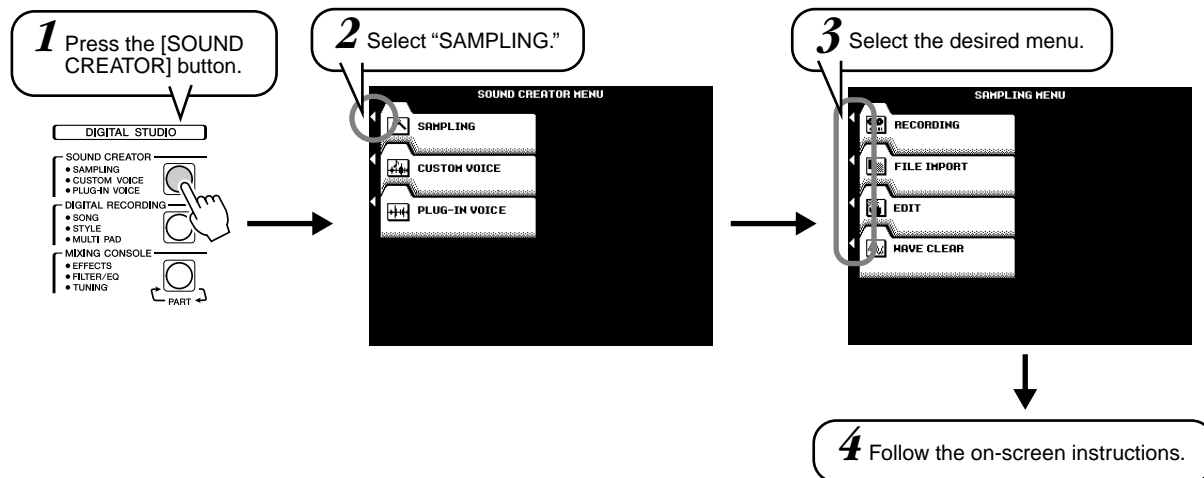

Refer to "Quick Guide" on page 40 for details.

The operations for each function corresponding to step #4 are covered in the following explanations.

Recording a Sample

Quick Guide on page 40

Refer to page 40 for instructions on recording a sample.

The following display will be shown in step #9 on page 40.

RECORDING
Specify the key range. You can also set the range by holding [DIRECT START/END] and pressing the appropriate keys. The pitch will not be changed if [FIXED PITCH] is on. Press [NEXT] to continue.

C4 C5 C6 C7 C8

DIRECT START KEY
DIRECT END KEY

START KEY: C-2 END KEY: G8 FIXED PITCH: ON/OFF

You can set the START/END KEY by pressing the desired key while holding either of the LCD buttons.

Set this parameter to ON if you want the sample to play back at the same pitch over the entire key range of the 9000Pro.

Set the key range to which the new sample will be assigned.

When FIXED PITCH above is set to OFF, the new recorded sample will be assigned to C3. Notice that the pitch and speed of the sample "follows" the keyboard: Playing keys lower than the original results in a lower pitch and slower speed; playing higher keys results in higher pitch and faster speed.

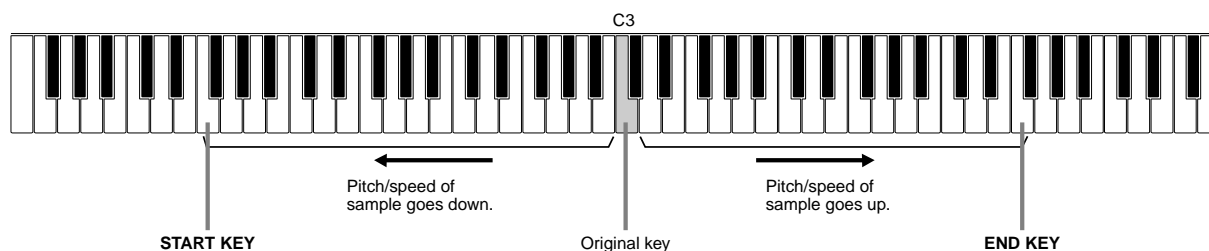

■ Pre Effect

You can set up a maximum of three DSP effects to be applied to the source sound as it is sampled. The DSP blocks are connected in series as shown below. The following display will be shown in step #10 on page 40.

DSP 1-3 are applied to the audiosignal. Adjust the settings as desired. Press [NEXT] or [BACK].

Select the desired DSP block.

Select the desired type of the selected DSP block.

TYPE	PARAMETER	VALUE	WET/DRY
OD+2RotSP	HPF Cutoff		127
Amp+2RotSP	Drive	16.0KHZ	
HmEnhance1	Mix Level		
PitchCh91			

Select the parameter and adjust the value of the selected parameter. Note that the contents of the parameter may be different depending on the selected DSP type.

Press this button to switch between the currently selected wave and the currently selected panel voice.

Select this to call up the storing display.

Change the balance between the direct (dry) and effect (wet) sound.

Importing Wave Files from Disk

To import previously saved waveform files via the PSR-8000 or standard WAV or AIFF format files from disk, insert the appropriate disk into the 9000Pro floppy disk drive, then press the [FILE IMPORT] LCD button in step #3 in "Basic Procedure" on page 86.

Select this and press the [NEXT] button to call up the display that imports the WAV or AIFF format file.

Select this and press the [NEXT] button to call up the display that imports the wave data sampled via the PSR-8000.

Clearing Wave Data

The explanations here apply to step #4 of the Basic Procedure on page 86.

Press this button to switch between the currently selected wave and the currently selected panel voice.

Select this to execute the Clear operation.

CUSTOM VOICE	HAVE FORM	HAVE
Voice01	1	HAVE001
Voice02	2	HAVE002
Voice03	3	HAVE003
Voice04	4	HAVE004

Editing Wave data

The illustration below applies to step #4 of the Basic Procedure on page 86.

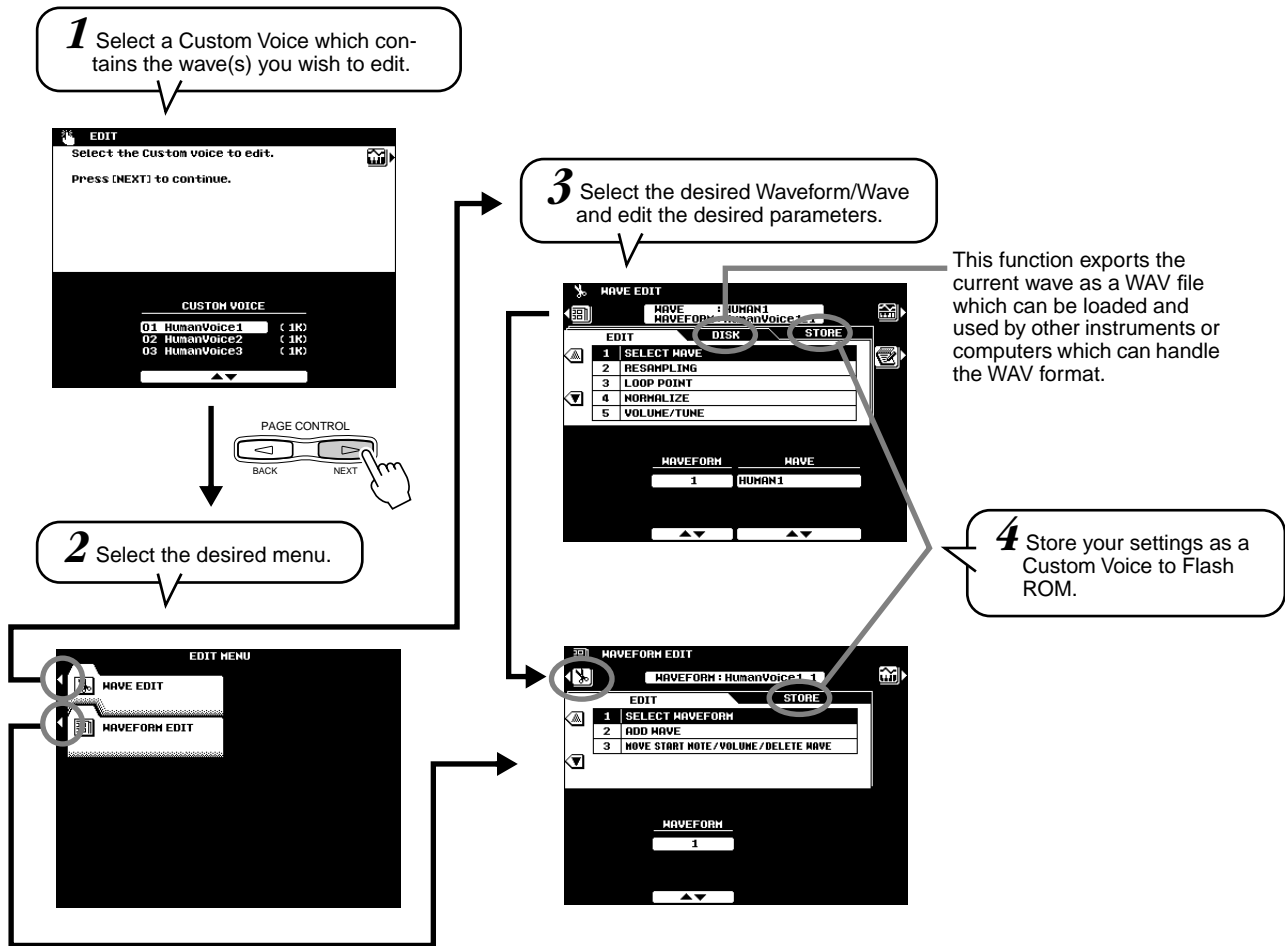

Wave Edit

Resampling

The 9000Pro originally records waves at 44.1 kHz. WAV and AIFF files are also imported as 44.1 kHz waves. The RESAMPLING function lets you reduce the sampling frequency of waves, thus reducing the amount of memory they occupy. Please note, however, that reducing the sampling frequency also reduces the sound quality.

Press this to hear how the resampled wave will sound before actually resampling the wave.

Press this to actually resample the selected wave.

NOTE

- Resampling can cause the loop points (see Loop Point, below) to shift, resulting in unwanted noise. If this happens use the Loop Point function to readjust the loop points.

Select the desired resampling frequency. Only resampling frequencies which are lower than the original sampling frequency will be available.

● Loop Point

This display determines how your sampled waves play back.
Your sampled waves can be played back in three different ways as follows:

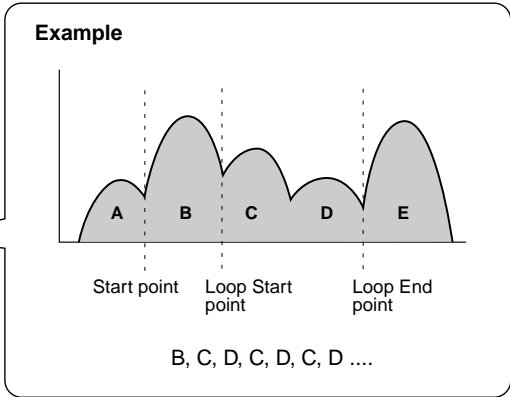
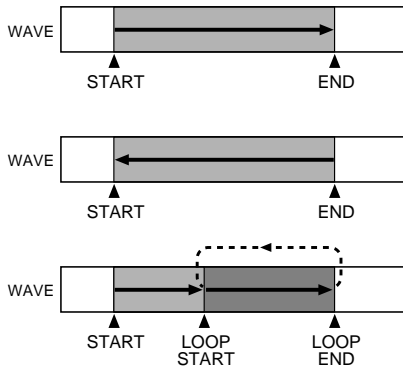

Press this to actually edit the selected wave.

The LEVEL indicators the right of each address show the signal level at the current address — the longer the bar, the higher the signal level. This makes it easier to locate zero-level points for noise-free trimming and looping.

See above.

When the ONE SHOT or REVERSE is selected, select either the Start or End address of the wave.
When the LOOP is selected, select the Start, Loop Start or Loop End address of the wave.

Press this to automatically remove all data prior to the specified Start point and after the End or Loop End point of your sample. See the illustration below.

When this is turned ON, the LOOP ADDRESS LCD buttons will automatically only select points in the wave corresponding to, or adjacent to, zero level points.

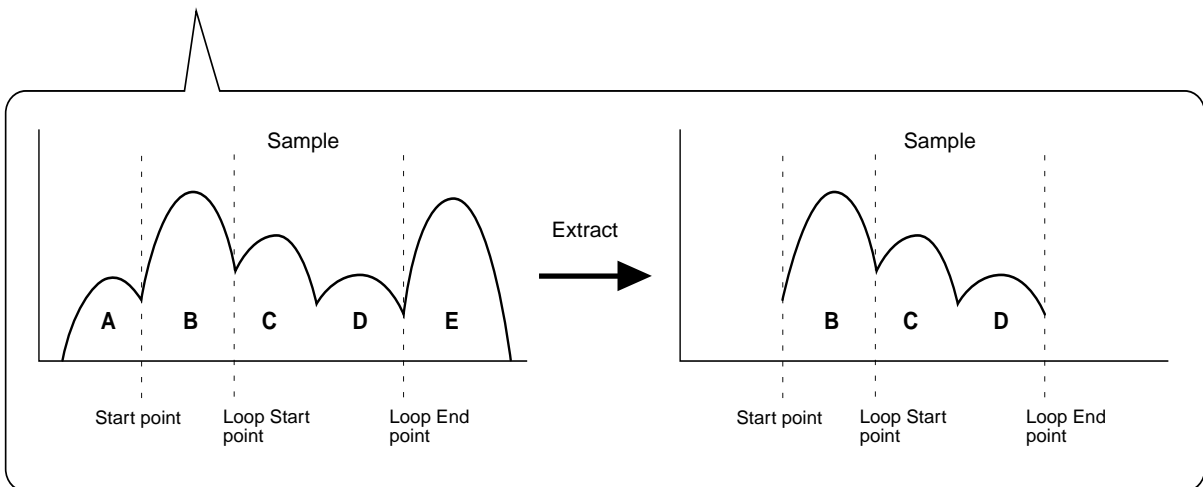

● Normalize

This function increases the overall level of the selected wave to ensure that it uses the full range of digital values. Press the EXECUTE LCD button to normalize the selected wave. No change will occur if the selected wave already uses the full range of digital values.

● Volume/Tune

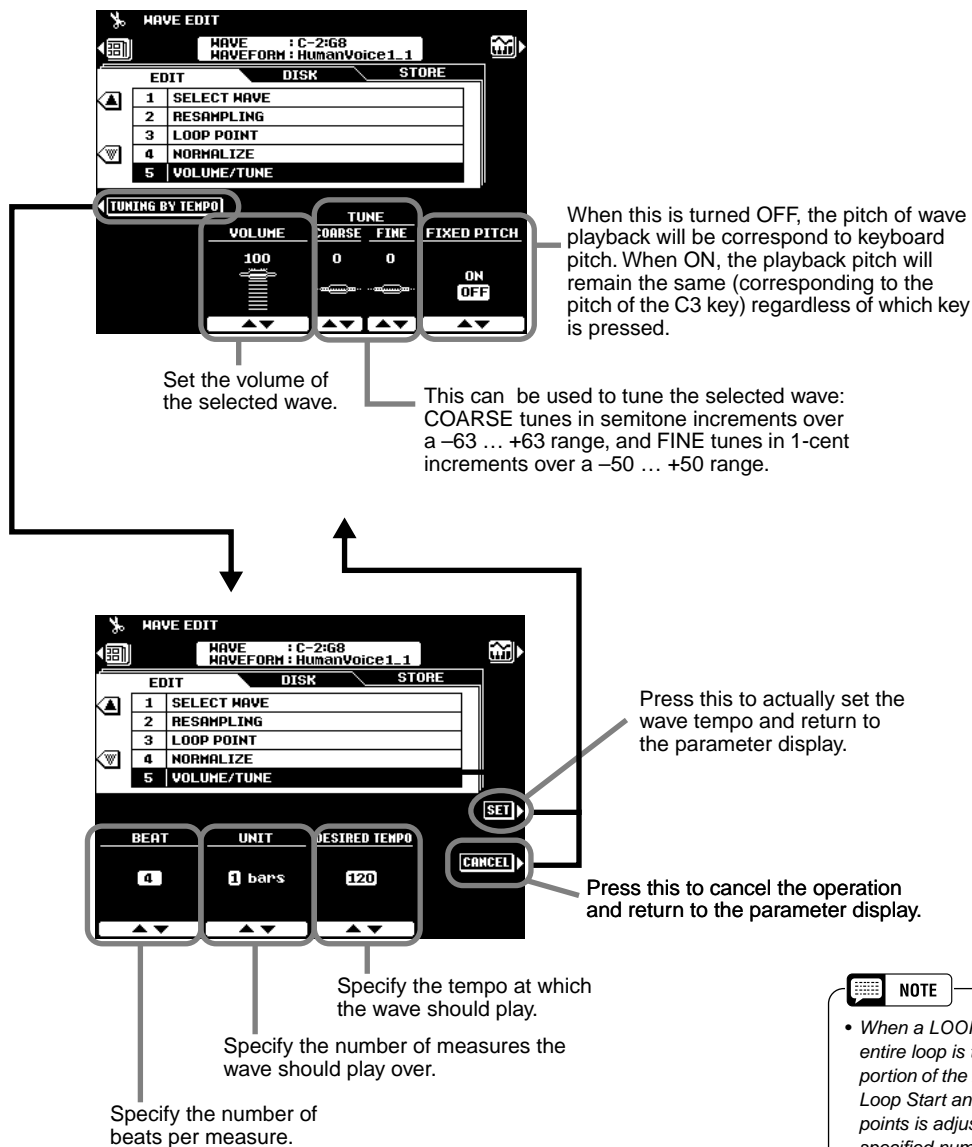

This display can be used to “tune” the wave to fit a specified playback tempo. In other words, the wave is stretched (tuned down) or compressed (tuned up) so that it plays back over the specified number of measures at the specified time signature and tempo. This capability is particularly useful when the sample is a phrase rather than a simple sound. The wave will only play back at the specified tempo, however, when played at its original pitch (usually the pitch played by the C3 key).

To ensure smooth looping, adjust the Loop Start/Stop point before using this function.

Waveform Edit

● Add Wave

This function can be used to add a wave from a different waveform to the currently selected waveform. When a waveform contains two or more waves, the individual waves must be assigned to different areas of the keyboard (the waves cannot be “layered”).

The Start Note at right in the display can also be specified by pressing the appropriate key on the keyboard while holding this button.

Press this to actually add the selected wave.

Select the source wave to be added.

Specify the note from which the added wave will begin playing. For example, if you select C3 as the Start Note, the original wave will play up to B2, and the added waveform will play from C3 up.

NOTE

- The same wave cannot be added for use in multiple keyboard ranges.

● Wave Start Note/Volume/Delete Wave

The Start Note can also be changed by pressing the appropriate key on the keyboard while holding this button.

Select a wave to be edited.

Adjusts the volume of the selected wave in relation to other waves in the waveform.

Deletes the selected wave from the waveform. When a wave is deleted, the range of the next lowest wave will expand to include the range originally covered by the deleted wave. If the deleted wave is the lowest in the waveform (i.e. its START NOTE is C-2) the range of the next highest wave will expand downward to include the range of the deleted wave. The last wave in the waveform cannot be deleted.

Move the start note of the selected wave (see “Add Wave”, above). The Start Note of the lowest wave in the waveform (i.e. the wave starting at C-2) cannot be changed. When the Start Note of a wave is changed, the range of the next lowest wave in the waveform will expand or contract accordingly.

The 9000Pro has a Custom Voice Creator feature that allows you to create your own voices. Once you've created a voice, you can store it to a Custom voice location for future recall.

Basic Procedure

1 Press the [SOUND CREATOR] button.

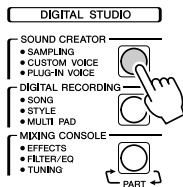

2 Select "CUSTOM VOICE."

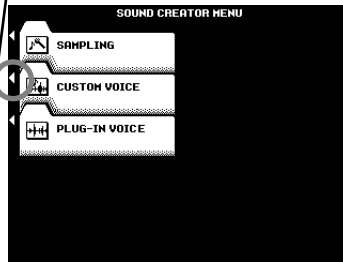

4 Press this button.

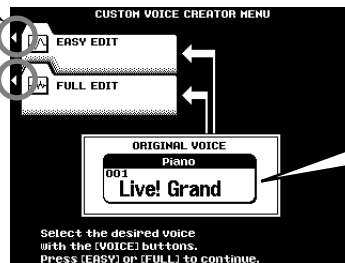

3 Select a Preset voice. The Custom Voice Creating mode makes it possible to create new voices by editing some parameters of the preset voices. After selecting a voice, press the [EXIT] button to return back to this display.

NOTE

- The following voices cannot be edited via the Custom Voice Creator.
 - Organ Flutes
 - Live! StdKit
 - Live! FunkKt
 - Arabic Kit
 - SFX Kit1
 - SFX Kit2
 - Plug-in Voice
- Drum or Percussion voices cannot be edited via Easy Edit.
- Keep in mind that adjustments made to the parameters may not make much change in the actual sound, depending on the original settings of the voice.

5 Edit the voice parameters.

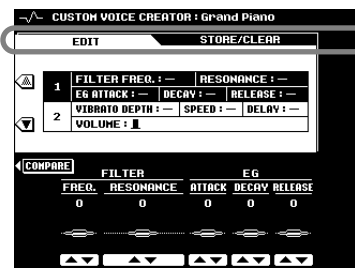

Select the desired menu by pressing the [NEXT]/[BACK] button.

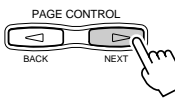
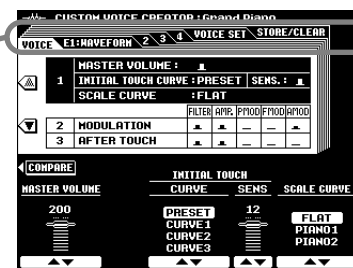

6 Store the edited voice to Flash ROM by following the on-screen instructions.

7 Press the [CUSTOM VOICE] button to select the edited voice and play the keyboard.

The operations for each function corresponding to step #5 are covered in the following explanations.

Easy Editing

Parameters

FILTER	Determines the timbre of the voice. See below for details.
EG	The EG (Envelope Generator) parameters affect the volume envelope of the voice. See below for details.
VIBRATO	Sets up the vibrato effect. See below for details.
VOLUME	Determines the volume of the voice.

● FILTER (FREQ. and RESONANCE)

These settings determine the overall timbre of the sound by boosting or cutting a certain frequency range. In addition to making the sound either brighter or more mellow, Filter can be used to produce electronic, synthesizer-like effects.

- **FREQ.** Determines the cutoff frequency or effective frequency range of the filter. (See diagram below.) Higher values result in a brighter sound.

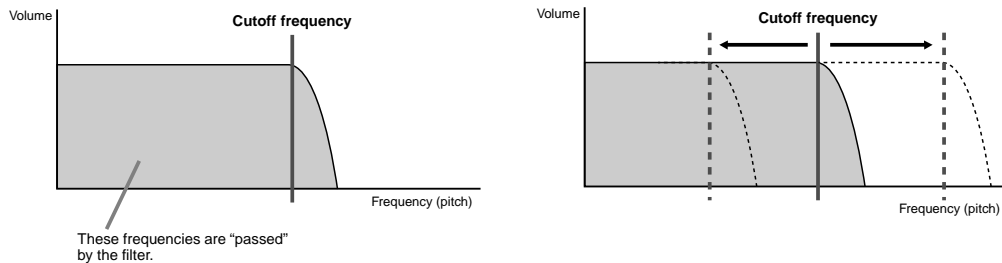

- **RESONANCE** . Determines the emphasis given to the cutoff frequency, set in Cutoff above. (See diagram below.) Higher values result in a more pronounced effect.

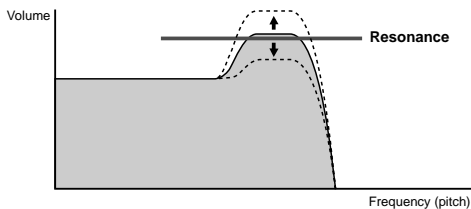

● EG

The EG (Envelope Generator) settings determine how the level of the sound changes in time. This lets you reproduce many sound characteristics of natural acoustic instruments — such as the quick attack and decay of percussion sounds, or the long release of a sustained piano tone.

- **ATTACK**..... Determines how quickly the sound reaches its maximum level after the key is played. The higher the value, the quicker the attack.
- **DECAY** Determines how quickly the sound reaches its sustain level (a slightly lower level than maximum). The higher the value, the quicker the decay.
- **RELEASE** Determines how quickly the sound decays to silence after the key is released. The higher the value, the shorter the release.

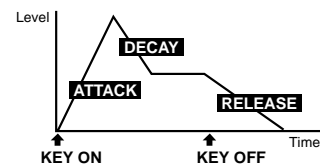

● VIBRATO

- **DEPTH**..... Determines the intensity of the Vibrato effect (see diagram). Higher settings result in a more pronounced Vibrato.
- **SPEED**..... Determines the speed of the Vibrato effect (see diagram).
- **DELAY** Determines the amount of time that elapses between the playing of a key and the start of the Vibrato effect (see diagram). Higher settings increase the delay of the Vibrato onset.

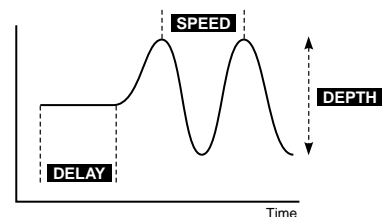

Full Editing

■ Element selection

Each 9000Pro voice can have up to eight separate “elements.” These elements are the basic sonic building blocks of the sound — with each element having its own waveform, envelope generator settings, and other parameters.

When editing in the E1:WAVEFORM, E2:EG, E3:FILTER, or E4:LFO pages you can select the element to be edited, set the maximum number of elements to be used by the voice, and mute individual elements via the ELEMENT page accessed by this button.

You can select the desired element by pressing these buttons.

Sets the element to be edited when you return to the editing pages.

Sets the maximum number of elements to be used by the voice.

These parameters individually turn the corresponding elements ON or OFF. The circular indicators next to the element numbers in the upper section of the display indicate the mute status for each element.

Element	COARSE TUNE	FINE TUNE	VOLUME	KEY ON DELAY	PAN
1	0	0	183	0	L63
2					
3					

Element	Name	Mute Status
1	Grand Piano_1	ON
2	Grand Piano_2	ON
3		OFF
4		OFF
5		OFF
6		OFF
7		OFF
8		OFF

■ Parameters

● VOICE

Select the desired menu.

Can be used during editing to compare the sound of the original voice with the edited voice.

Sets the amount of Filter, Amplitude and LFO modulation types (PMOD, FMOD, AMOD) applied via the MODULATION wheel and via keyboard After Touch response. See page 98 for details about LFO.

Sets the overall volume of the current edited voice.

Selects the desired scale (pitch) curve to be used by the current edited voice for the 9000Pro keyboard.

The CURVE LCD button provides a choice of four keyboard initial touch sensitivity curves, and the SENS LCD buttons adjust initial touch sensitivity.

Parameter	Value
MASTER VOLUME	200
INITIAL TOUCH CURVE	PRESET
INITIAL TOUCH SENS	12
SCALE CURVE	FLAT

● E1: WAVEFORM

See page 85 for details about Waveform.

NOTE LIMIT specifies the note range over which the voice will sound, and VELOCITY LIMIT sets the maximum velocity range for the voice.

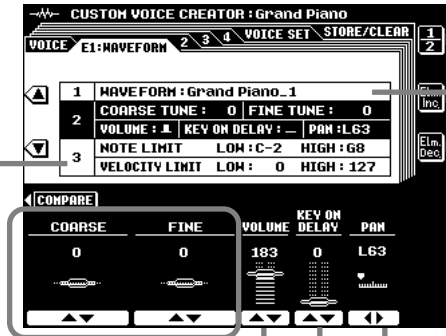

Use the CATEGORY, VOICE, and WAVEFORM LCD buttons to select the waveform for the custom voice. (This is the “raw” sound on which the voice is based.) Waveforms created by the SAMPLING feature (page 84) are also available for selection in the “SAMPLING” CATEGORY.

NOTE

- When a Drum Kit is selected, the WAVEFORM parameter is replaced by the INSTRUMENT parameter, and individual instruments can be selected rather than waveforms.

These parameters adjust the pitch of the voice. COARSE tunes in semitone steps and FINE tunes in 1-cent steps (a cent is 1/100th of a semitone).

Sets the position of the voice in the stereo field.

Sets the amount of delay before the sound is heard — in other words, the time between when the key is pressed and when the envelope begins. The higher the value the longer the delay.

Sets the waveform volume.

• Example for NOTE LIMIT

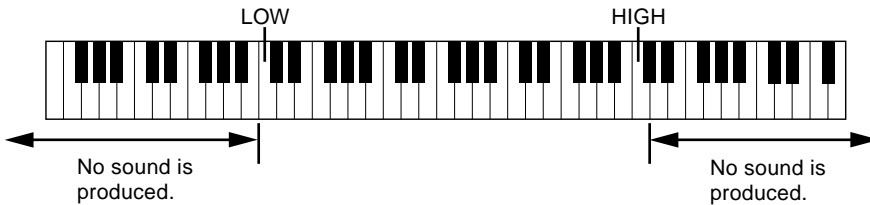

NOTE

- When the voice OCTAVE is set to a value other than “0”, the range specified by the NOTE LIMIT parameters is shifted by the corresponding amount and some notes may not sound. If this happens check the R1 OCTAVE setting in the MIXING CONSOLE TUNE display.
- NOTE LIMIT and VELOCITY LIMIT are not available for the Drum Kits.

• Example for VELOCITY LIMIT

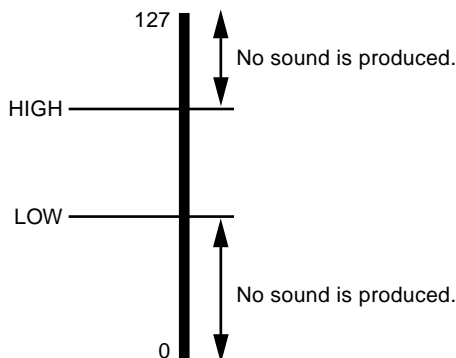

● E2: EG

An acronym for Envelope Generator, a block that modifies the level of the tone generator from the moment that a note is played until the sound decays to silence. The Amplitude EG controls the volume level, the Pitch EG controls the pitch, and the Filter EG controls the filter cutoff frequency.

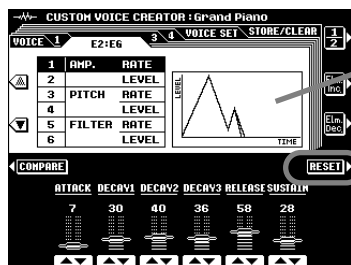

Indicates the EG settings as a diagram.

Resets the currently selected EG parameters to their most basic settings.

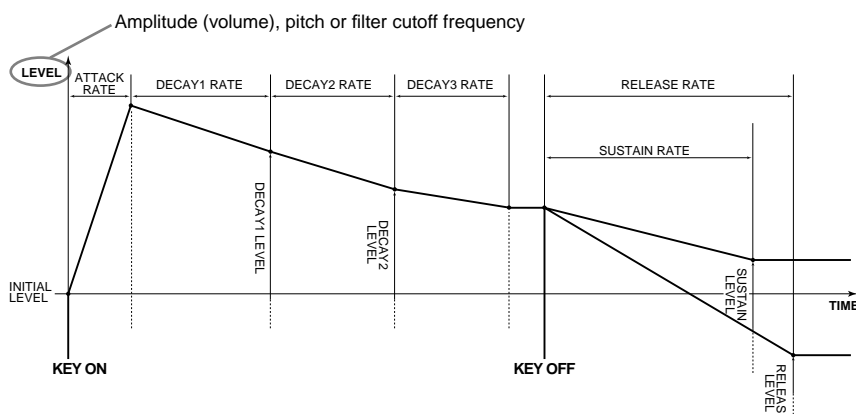

* Higher rate values produce faster variation.

• AMP. RATE and AMP. LEVEL (Amplitude EG settings)

The AMP. RATE parameters are time-related; they determine how long it takes for the sound volume to change from level to level (as set in AMP. LEVEL).

The AMP. LEVEL parameters are volume-related; they determine how loud or soft the volume changes are over time (as set in AMP. RATE).

AMP.RATE	ATTACK	Sets the rate of variation from key-on to the maximum attack level.
	DECAY1 DECAY2 DECAY3	Set the rate of variation between the maximum attack level and the levels set by the AMP LEVEL DECAY1 and DECAY2 parameters and the final level, respectively.
	RELEASE	Sets the rate of variation from the level at key-release to level 0 when SUSTAIN is off.
	SUSTAIN	Sets the rate of variation from the level at key-release to level 0 when SUSTAIN is on.
AMP.LEVEL	INITIAL	Sets the initial level of the envelope.
	DECAY1 DECAY2	Set the levels following the elapsed time of DECAY 1 and DECAY 2, respectively.

• PITCH RATE and PITCH LEVEL (Pitch EG settings)

The PITCH RATE parameters are time-related; they determine how long it takes for the sound's pitch to change from level to level (as set in PITCH LEVEL).

The PITCH LEVEL parameters are pitch-related; they determine how much the sound deviates from normal pitch over time (as set in PITCH RATE).

PITCH RATE	DECAY1 DECAY2 DECAY3	Set the rate of variation between the initial pitch envelope level and the levels set by the PITCH LEVEL DECAY1, DECAY2, and DECAY3 parameters, respectively.
	RELEASE	Sets the rate of variation from the level at key-release to the level set by the PITCH LEVEL RELEASE parameter.
PITCH LEVEL	INITIAL	Sets the initial pitch of the envelope.
	DECAY1 DECAY2 DECAY3	Set the amounts of pitch change following the elapsed time of DECAY 1 and DECAY 2, respectively.
	RELEASE	Sets the final pitch of the envelope; the pitch goes to this point (at the RELEASE rate) after the key is released.

• **FILTER RATE and FILTER LEVEL (Filter EG settings)**

The FILTER RATE parameters are time-related; they determine how long it takes for the sound's timbre to change from level to level (as set in FILTER LEVEL).

The FILTER LEVEL parameters are filter-related; they determine how much the sound changes in timbre over time (as set in FILTER RATE). A setting of "0" is the default value.

FILTER RATE	INITIAL	Sets the length of time the initial filter envelope level will be maintained. Higher values correspond to shorter time.
	DECAY1 DECAY2 DECAY3	Set the rate of variation between the initial filter envelope level and the levels set by the FILTER LEVEL DECAY1, DECAY2, and DECAY3 parameters, respectively.
	RELEASE	Sets the rate of variation from the offset at key-release to the offset set by the FILTER LEVEL RELEASE parameter when SUSTAIN is off.
	SUSTAIN	Sets the rate of variation from the offset at key-release to the offset set by the FILTER LEVEL SUSTAIN parameter when SUSTAIN is on.
FILTER LEVEL	INITIAL	Sets the initial timbre of the envelope.
	DECAY1 DECAY2 DECAY3	Set the amounts of timbre change following the elapsed time of DECAY 1, DECAY 2, and DECAY 3, respectively.
	SUSTAIN	When SUSTAIN is on, this sets the final timbre of the envelope; the filter setting changes to this point (at the RELEASE rate) after the key is released.

● **E3: FILTER**

The 9000Pro features two independent filters. (For basic information about the filters, see page 93.)

Sets the amount of peak resonance applied to FILTER 1. Higher values produce more resonant emphasis.

The TYPE parameters specifies the touch-sensitivity curve to be applied to the dynamic filters, and the SENS parameters sets the sensitivity of the filters to touch control. Higher values produce higher sensitivity.

Resets the currently selected EG parameters to their most basic settings.

Sets the cutoff frequency of Filter2.

Selects the type of Filter2.

Sets the cutoff frequency of Filter1.

Selects the type of Filter1.

Filter types

LPF (Low Pass Filter)

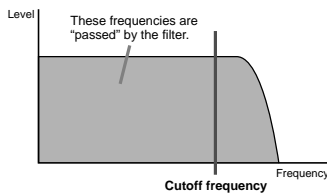

HPF (High Pass Filter)

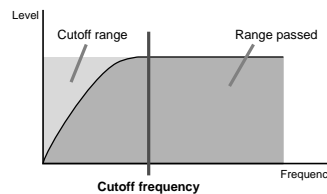

BPF (Band Pass Filter)

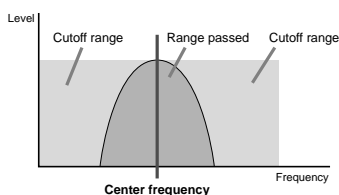

BEF (Band Elimination Filter)

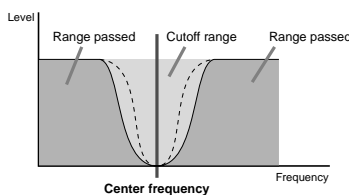

Custom Voice Creating

● E4: LFO

An acronym for Low Frequency Oscillator, a block that produces a low frequency signal. The LFO can be used to modulate pitch, filter cutoff frequency, or amplitude to create a wide range of modulation effects.



Vibrato effect based on LFO modulation, with a variable delay between the time a key is played and the beginning of the vibrato effect.
See the diagram below.

See the diagram below.

Selects the LFO wave. Various kinds of modulated sounds can be created depending on the selected wave.
See the diagram below.

See the diagram below.

Sets the speed of LFO variation.

Abbreviation for "Amplitude Modulation." This determines how greatly the LFO will affect the output level. Larger values widen the range of the volume change.

Abbreviation for "Filter Modulation." This determines how greatly the LFO will affect the filter cutoff frequency. Larger values widen the range of change in the cutoff frequency.

Abbreviation for "Pitch Modulation." This determines how greatly the LFO will affect the pitch. Larger values widen the range of the change in pitch.

• TYPE (LFO wave type)

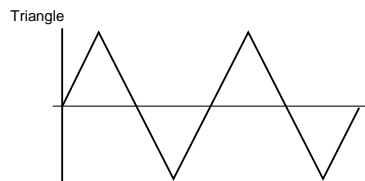
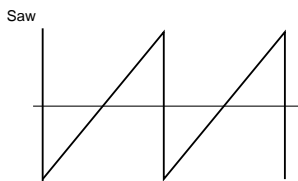

• DELAY TIME

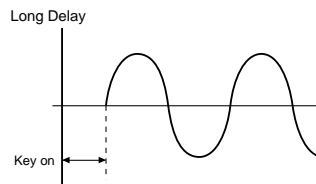
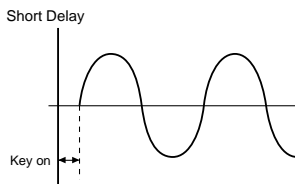

• DELAY RATE

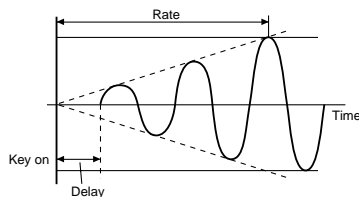

● VOICE SET

See page 163 for details about the Voice Set function.
 You can specify the Voice Set data to the Custom Voice.



Creating Plug-in Custom Voices

Just as with the preset voices, you can use the voices of the Plug-in Board as basic material for crafting your own original Plug-in voices. Once you've created a voice, you can store it to a Plug-in Custom voice location for future recall.

Guidelines

■ Memory Structure of the Plug-in Voices

The illustration below is basically same as the one on page 64.

The illustration on page 64 describes the relationship between each menu of the Plug-in Manager function and the voice data on the Flash ROM/board. The illustration below, however, shows the relationship between each menu of the Plug-in Custom Voice Creator function (explained in this chapter) and the voice data on the Flash ROM/board.

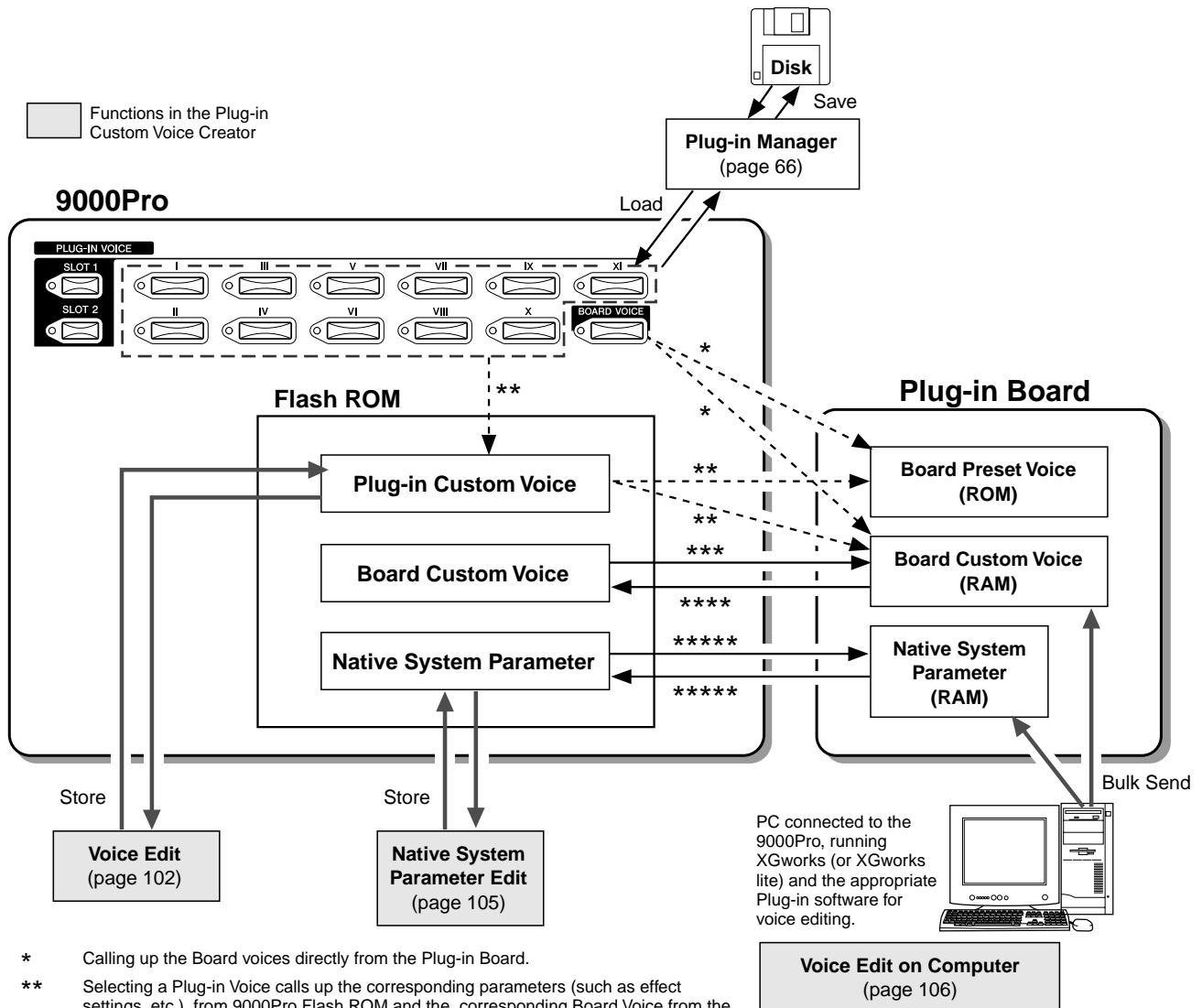

Basic Procedure

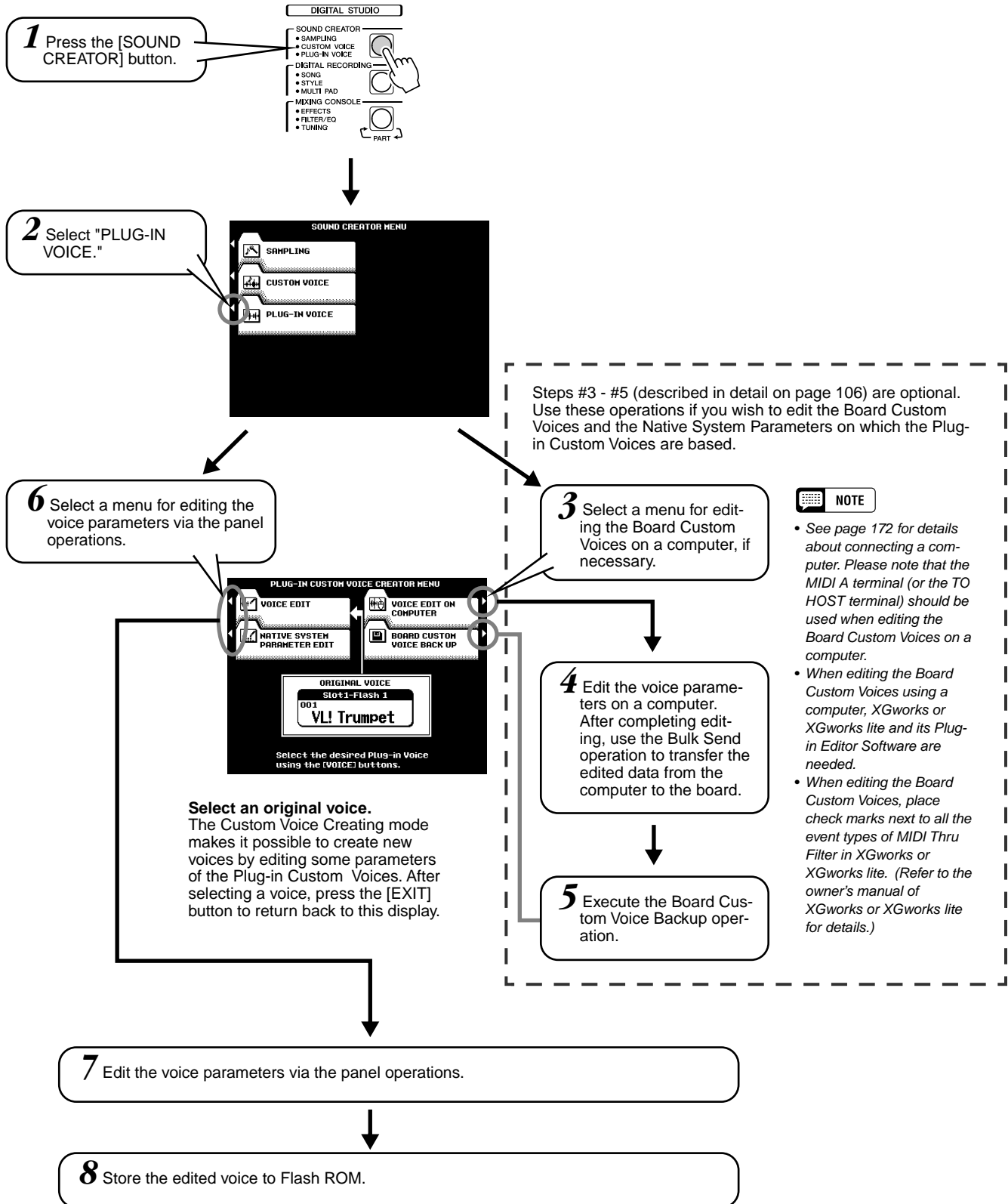

Editing operations (corresponding to step #4 or #7) are covered in the following explanations.

Voice Editing

Board Voice selection

The explanations here apply to step #7 on page 101.

Select the desired menu and edit the voice parameters.

Can be used to compare the sound of the originally selected voice with the changed voice.

Select this to store the edited voice parameters to Flash ROM (step #8 on page 101).

Select the Board Voice.

NOTE

- Keep in mind that some of your editing may have little to no effect on the actual sound, depending on the particular board and the particular parameter being edited.

Before entering the Plug-in Custom Voice Creator function, you have already called up a specific voice for editing. Selecting a Board voice here lets you determine the basic sound source, letting you select a variation sound for the voice.

Parameters

The explanations here apply to step #7 on page 101.

● E1: EG/VIB

The explanations of each parameter are same as Easy Editing in the Custom Voice Creating section on page 93.

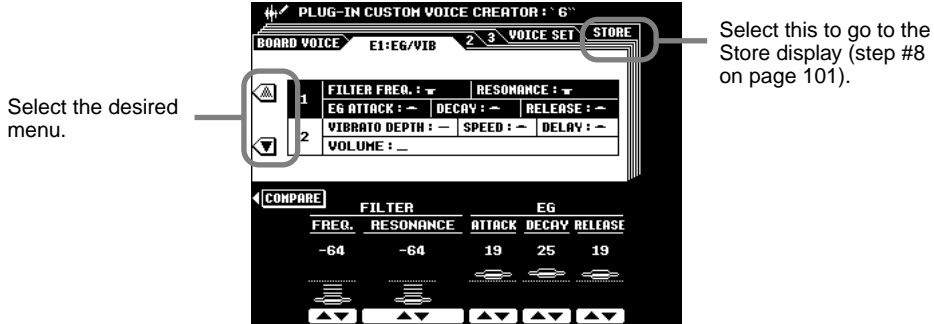

● E2: CTRL (Control)

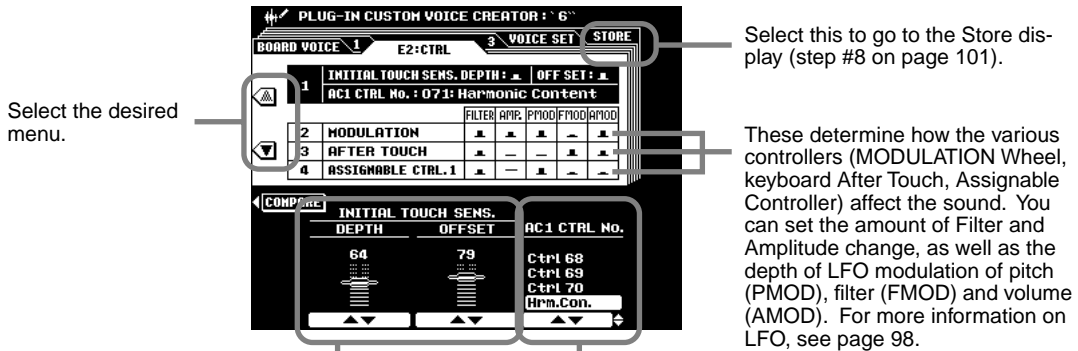

Sets the depth and the offset of the Initial Touch Sensitivity.

This determines which Control Change number will be used for Assignable Controller 1. This function is available only for Plug-in Boards that support the Assignable Controller (AC1).

HINT

In this example, the PLG150-AN is installed to the 9000Pro and the MODULATION Wheel is used to change the sound of the Plug-in voice. Make the following settings on the 9000Pro:

- 1) Set the AC1 CTRL No. to Mod.
- 2) Select the desired AC1 Control Parameter (e.g., P:34) in the Native Part Parameter display.
- 3) Adjust the AC1 Control Depth in the Native Part Parameter display.

When you play the keyboard and move the MODULATION Wheel, the sound of the Plug-in voice changes according to the AC1 Control parameter you selected in step #2.

Creating Plug-in Custom Voices

● E3: NATIVE PRM. (Native Part Parameter)

The word “native” here describes the parameters that are exclusive to each of the Plug-in Boards. Because of this, the editing screens displayed on the 9000Pro will differ depending on the particular Plug-in Board being used. For example, when editing Plug-in voices of the PLG150-DX, parameter names such as “Carrier” and “Modulator” which are unique to the FM Synthesis system are displayed, as shown below on the left. Likewise, when editing Plug-in voices of the PLG150-VL, the 9000Pro displays parameters unique to the VL tone generation system such as “Brth Mode” (Breath Mode) and “Emb CC No.” (Embouchure Control Change Number), as shown below on the right.

• When editing a DX plug-in voice:

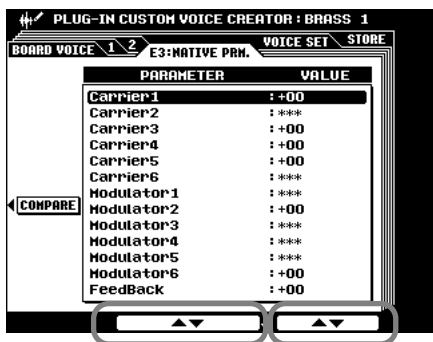

Select the desired parameter.

Specify the value.

• When editing a VL plug-in voice:

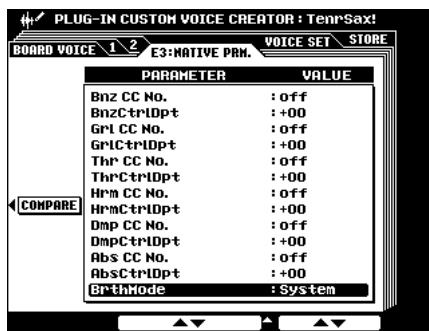

For details about Native Part Parameters, refer to the Owner's Manual of your Plug-in Board.

● VOICE SET

See page 163 for details about the Voice Set function.

You can specify the Voice Set data to the Plug-in Custom Voice.



Native System Parameter Editing

The word “native” here describes the parameters that are exclusive to each of the Plug-in Boards. Because of this, the editing screens displayed on the 9000Pro will differ depending on the particular Plug-in Board being used. For example, when editing Plug-in voices of the PLG150-VL, parameter names such as “WX Lip” and “Brth Curv” (Breath Curve) which are unique to the VL tone generation system are displayed, as shown below on the right.

The illustration below applies to step #7 of the Basic Procedure on page 101.

You can store the settings in this display to Flash ROM by using this button.

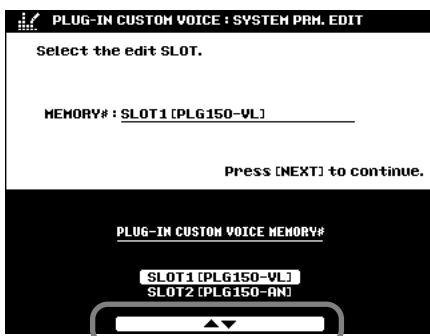

Select the desired Board.

When the same (or same type) of Plug-in Boards (e.g., the PLG100-DX and the PLG150-DX) have been installed in the two slots, only SLOT 1 is available.

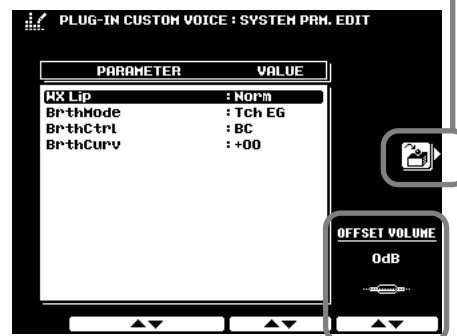
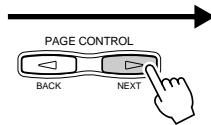

This lets you change the volume output from the Plug-in Board and adjust the relative balance among the 9000Pro preset voices and the Plug-in voices.

Please note the following points.

- The volume balance of the song using the Plug-in voices is changed by adjusting this value.
- When the same (or same type) of Plug-in Boards have been installed in the two slots, only the value set for SLOT 1 is available.

Voice Editing on a Computer

You can edit Board Custom Voices and Native System Parameters from your computer, using special plug-in software for the XGworks (or XGworks lite) program.

- ▶ **1 Connect your personal computer to the 9000Pro.**
See page 172 for details about connecting a computer. Please note that the MIDI A terminal (or the TO HOST terminal) should be used when editing the Board Custom Voices on a computer.
- ▶ **2 Install the software to the computer.**

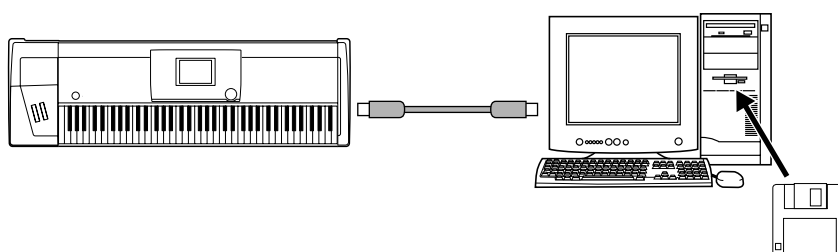

The following software is required.

- **XGworks or XGworks lite**

Please see the readme.txt file that can be found in the XGworks lite folder.

- **CBX driver for Windows or USB driver**

Please see the readme.txt file that can be found in the CBX driver folder or in the USB driver folder.

- **Plug-in Editor Software for XGworks (lite)**

For installation instructions, refer to the Owner's Manual of your particular Plug-in Board.

	Plug-in Editor Software
PLG100-VL, PLG150-VL	VL Visual Editor
PLG100-DX, PLG150-DX	DX Easy Editor, DX Simulator
PLG150-AN	AN Easy Editor, AN Expert Editor
PLG150-PF	PF Easy Editor

Place check marks next to all the event types of MIDI Thru Filter in XGworks or XGworks lite, when editing the Board Custom Voices.

- ▶ **3 If necessary, save any important voice data (Board Custom Voice and Native System Parameter data in Flash ROM) by using the Plug-in Manager function (page 68).**

- ▶ **4** Load the appropriate files to both the 9000Pro and your computer.

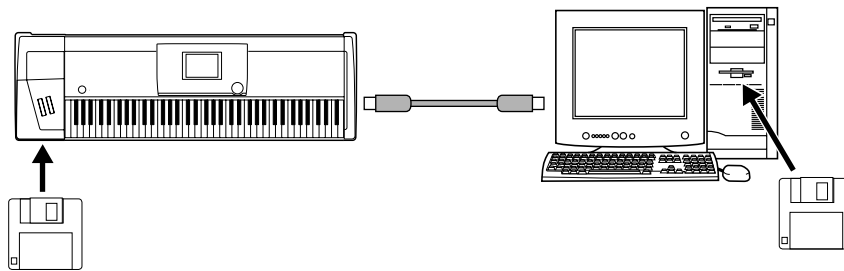

● **When editing voices on an installed Plug-in Board for the first time:**

Make sure to load the appropriate files (on the floppy disk included with the 9000Pro) to the 9000Pro as follows. For the PLG150-AN board only, you'll need to also load the appropriate file (below) to your computer.

	File name to be loaded	
	to the 9000Pro	to the PC
PLG150-AN	150AN CsVce.xvc	150AN CsVce.ANS
PLG150-PF	150PF CsVce.xvc	—
PLG150-DX	150DX CsVce.xvc	—
PLG150-VL	150VL CsVce.xvc	—

● **When editing voices on an installed Plug-in Board in subsequent editing sessions:**

Before starting to make additional edits to a previously edited voice, also make sure to load the same edited data (the data that you saved in steps #7 and #8) to both the Flash ROM (on the 9000Pro) and the computer.

- ▶ **5** Use the same operation as in Steps #1 - #5 of the "Basic Procedure" on page 101, paying attention to the following points.

- In step #4 of "Basic Procedure," the following display appears on the 9000Pro's LCD.

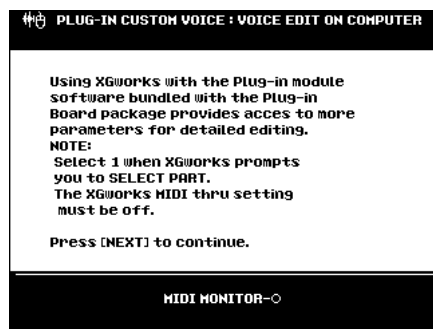

- As described in step #4 of "Basic Procedure," use the Bulk Send operation (XGworks or XGworks lite) to transfer the edited data from the computer to the board.
- As described in step #5 of "Basic Procedure," execute the Board Custom Voice Backup operation.

- ▶ **6** Execute the Store operation in the Native System Parameter display (page 105).
- ▶ **7** Save the edited voice to a disk via the Plug-in Manager function (page 68).
- ▶ **8** Save the edited voice to the PC.

Board Custom Voice Backup

Any editing you do to the Board Custom Voices (via computer connected to the 9000Pro) is lost when you turn off the power of the 9000Pro. If you want to keep your original voice data, you can use the Board Custom Voice Backup function to back up the edited Board Custom Voices to Flash ROM.

The illustration below applies to step #5 of the Basic Procedure on page 101.

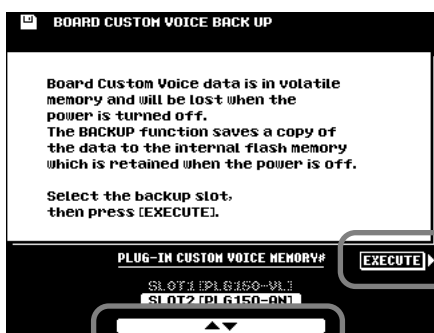

Select the desired board.

Press this to execute the Backup operation.

NOTE

• Some Plug-in Boards (e.g., the PLG100-DX and the PLG100-VL) do not support this function, even though the Board Custom Voices are available.

Troubleshooting when using the Plug-in Boards

General information on how to use the Plug-in Voices is given on pages 42, 43, 64 - 69, and 100 - 108. This section explains some important details concerning the Plug-in Boards that are not covered in these pages.

■ Using the VL Plug-in voices with Harmony function (page 164)

If you are using one of the VL Plug-in Boards (or a monophonic Plug-in voice), the Harmony effect cannot be used as normal. It is because this type of voice cannot be played polyphonically.

For example, when the Plug-in voice using the PLG150-VL board is selected as the Right 1 voice and Harmony Assign is set to R1, the following problem happens.

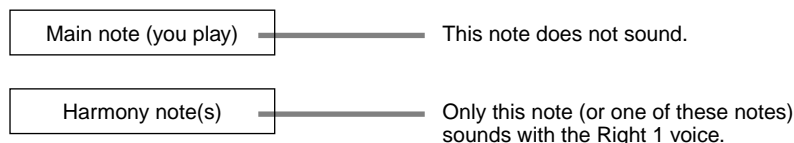

An alternate solution for this is to assign a different voice to the Harmony part, as shown in the example settings below.

- Right 1 Plug-in voice using the PLG150-VL board (e.g., Tenor Sax)
- Right 2 9000Pro preset voice (e.g., Miller Night)
- Part R1 and R2..... ON
- ASSIGN..... R2

This workaround lets you play the monophonic Plug-in voice for the melody, and use a different, yet complementary sound for the Harmony part.



■ **Using the Plug-in voices in Song Creator**

See page 125.

■ **Differences between the PLG150 and PLG100 series (Single Part Plug-in Boards)**

If you intend to use Single Part Plug-in Boards, Yamaha recommends that you use the PLG150 series boards exclusively. For this reason, the included floppy disk features voice data for PLG150 series Plug-in Boards. However, you can use the PLG100 series if you keep in mind the following points and anomalies.

● **Poly Expansion (page 69)**

If you have installed a PLG150 Board to SLOT 1 and a PLG100 Board to SLOT 2 (or, in other words, installed a higher level board of the same type to SLOT 1), and have set POLY EXPANSION to ON, you may experience certain problems when playing the voices.

When you have installed a PLG150-DX to SLOT 1 and a PLG100-DX to SLOT 2:

No problem should result when using the installed voices in both boards; however, if you try to play voices that do not exist on the PLG100-DX (SLOT2), the sound may drop out periodically. Make sure to use only those voices that are common to the two boards.

When you have installed a PLG150-VL to SLOT 1 and a PLG100-VL to SLOT 2:

If the Breath Mode of the PLG150-VL Native Part parameters (a parameter that does not exist on the PLG100-VL) is set to a value other than "System," the volume and timbre of the played voice changes every other note. Make sure to set the Breath Mode to "System" in this case.

● **Data compatibility**

The Board Custom Voices are not available in PLG100 series boards. As a result, data related problems will occur when loading the voice data from disk to Flash ROM with the Plug-in Manager function.

When you install the PLG100 series voice data with a PLG150 Board installed:

The Plug-in Voice using the Board Custom Voice may not sound appropriately, if the Board Custom Voice has been edited and Board Custom Backup has been executed. This is because the PLG100 series voice data does not contain the Board Custom Voice data.

When you install the PLG150 series voice data with a PLG100 Board installed:

- The Board Custom Voice data loaded from disk is not used. Therefore, voices using this data may sound different than expected or than originally programmed.
- If a PLG100-DX board is installed and you select a voice based on a voice that does not exist on the PLG100-DX board, no sound results.
- The Breath Mode setting of the PLG150-VL Native Part parameters is ignored, and the Breath Mode setting of the PLG100-VL Native System parameters is available.

■ **Setting the Unison Switch of the PLG150-AN board to on**

Plug-in Voices of the PLG150-AN for which Unison Switch (of the Native System parameters) has been set to on, cannot be played polyphonically — even if the 9000Pro's POLY/MONO button is set to POLY. Note that many of the Plug-in Custom Voices in the included disk are deliberately set to Unison On, to effectively recreate popular monophonic synthesizer sounds.

With the powerful and easy-to-use song creating features, you can record your own keyboard performances to a floppy disk as a User song, and create your own complete, fully orchestrated compositions. Each User song lets you record up to sixteen independent tracks. These include not only the voices for the keyboard performance (R1, R2, R3, L), but also the auto accompaniment parts and Vocal Harmony effect.

Guidelines for Song Creating

● Song Tracks

The tracks which can be recorded to the songs are organized as shown in the chart below.

Track	Default Part	Parts that can be set
1	Right1	VOICE R1, R2, R3, L, Accompaniment Style track, Multi Pad 1-4, Vocal Harmony, MIDI
2	Right1	
3	Right1	
4	Right1	
5	Right1	
6	Right1	
7	Right1	
8	Right1	
9	Accompaniment Style RHYTHM1 (Sub)	
10	Accompaniment Style RHYTHM2 (Main)	
11	Accompaniment Style BASS	
12	Accompaniment Style CHORD1	
13	Accompaniment Style CHORD2	
14	Accompaniment Style PAD	
15	Accompaniment Style PHRASE1	
16	Accompaniment Style PHRASE2	

● Multi Track Recording/Quick Recording

• Multi Track Recording

In Multi Track Recording, you determine the track assignments (as shown above) before recording. Several tracks can be recorded simultaneously. In addition to being able to record to empty tracks, you can also re-record tracks that already contain recorded data.

• Quick Recording

In Quick Recording, you can quickly record without having to worry about the track assignments above. Quick Recording automatically makes track assignments according to the simple rules below.

When "MANUAL" tracks are set to REC, your keyboard performances (VOICE R1, R2, R3, L) and Multi Pads playback are recorded to tracks 1-8 as listed below.

When "ACMP" tracks are set to REC, the auto accompaniment parts are recorded to tracks 9 ~ 16 as listed below.

Track	Part
1	Right1
2	Right2
3	Right3
4	Left
5	Multi Pad 1
6	Multi Pad 2
7	Multi Pad 3
8	Multi Pad 4

Track	Part
9	Accompaniment Style RHYTHM1
10	Accompaniment Style RHYTHM2
11	Accompaniment Style BASS
12	Accompaniment Style CHORD1
13	Accompaniment Style CHORD2
14	Accompaniment Style PAD
15	Accompaniment Style PHRASE1
16	Accompaniment Style PHRASE2

● Realtime Recording/Step Recording

• Realtime Recording

This method records performance data in real time, overwriting any data already present in the destination track. The new data replaces the previous data.

Basic information on recording a new song, refer to the "Quick Guide" on pages 36 and 38.

• Step Recording

This method lets you compose your performance by "writing" it down one event at a time. This is a non-realtime, step recording method - similar to writing music notation onto paper.

The Song Creator offers two different step recording types: Chord Step (available for Quick Recording) and Step Recording (available for Multi Track Recording).

Basic Procedure

1 Press the [DIGITAL RECORDING] button.

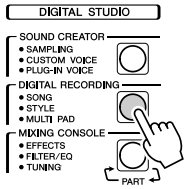

2 Select "SONG CREATOR."

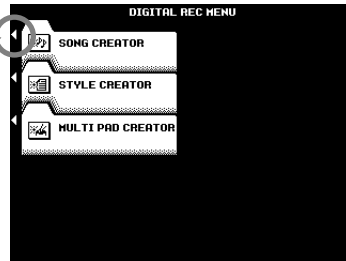

3 Select the desired menu.

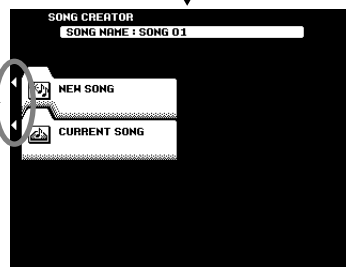

4 Select the Record method.



NOTE
 • If an optional hard disk has been installed or an optional SCSI device has been connected, you can also save the recorded song data to these in step #7.

When selecting "MULTI TRACK RECORD."

When selecting "QUICK RECORD."

5 Set up for the recording. — See page 112

● Multi Track Recording

Select the desired menu by pressing the [NEXT] or [BACK] button.

Select the part for the corresponding track.

Set the desired track to "REC."



Select this to call up the Step Recording display.

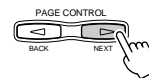

● Quick Recording

This screen appears only when selecting "CURRENT SONG" in step #3.

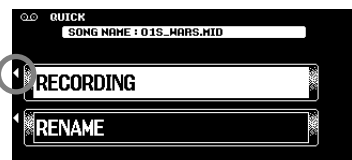

Select this to call up the Chord Step display.



6 Record your performance or edit the selected song.

7 Save the song to disk.

Track Setting for Recording (Multi Track Recording)

The explanations here apply to step #5 on page 111.

See page 125.

See "Part Selecting/ Record Selecting" on page 113.

Select the part for the corresponding track.

Select the desired menu.

Press [NEXT] when settings are ready. Press [START] to begin Rehearsal recording.

1 2 3 4 5 6 7 8 9 10
No data
Muted track
Play track
Record track

See "Delete" on page 113.

Set the desired track to "REC."

Select "REC MODE" which appears when selecting "CURRENT SONG" in step #3.

Select this to return to the TRACK main display.

Set the related parameter. For details, see below

REPLACE PUNCH IN 2

PUNCH IN TRIGGER FIRST KEYON FOOT SM1 FOOT SM2 AUTO SET 3 5

Available when "PUNCH IN TRIGGER" is set to "AUTO SET."

Record Mode

- Replace..... Follow the normal recording procedure described in the previous section. The only difference is that recording will begin from the measure specified at the MEASURE SET, and all data from that point to the end of the song will be replaced by the newly-recorded material.
- Punch In..... This function allows you to selectively re-record a portion of a song track (the measures between the specified punch-in and punch-out points).

HINT

• *Punch In recording has another exceptionally convenient advantage — it automatically records any panel settings you've made, allowing you to have various settings (such as voice, volume, pan, etc.) change instantly and automatically right before the Punch In point!*

In the eight-measure example below, measures 3 through 5 are re-recorded.

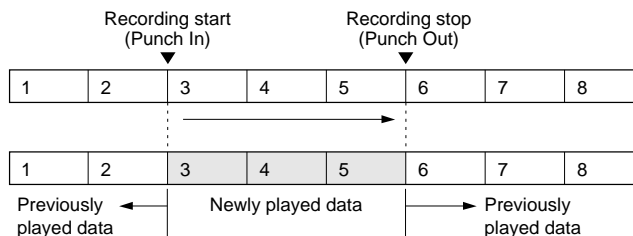

Measure Set

- When the RECORD MODE is set to "REPLACE," this parameter specifies the measure you want to start recording from.
- When the RECORD MODE is set to "PUNCH IN," this parameter specifies the first playback measure. Be sure to give yourself a few measures "lead-in" prior to the actual punch-in point.

■ Punch In Trigger

- First Key On When FIRST KEY ON is selected, recording will begin when the first key is played on the keyboard.
- Footswitch 1/2... When FOOT SW 1 or FOOT SW 2 is selected, recording will begin when a footswitch connected to the corresponding rear-panel FOOT SWITCH jack is pressed.
- Auto Set When AUTO SET is selected, the punch-in and punch-out measures are specified by the IN and OUT buttons (i.e., recording begins automatically at the IN measure and ends at the OUT measure).

■ Part Selecting/Record Selecting

The default part for each track is displayed above the REC setting. The parts can be changed as required by pressing the [PART SEL.] LCD button (the part names for each track will be highlighted), selecting the desired parts via the corresponding buttons. When the parts have been changed, press the [REC SEL.] LCD button (the PART SEL. LCD button will have changed to the [REC SEL.] LCD button) again to return to the normal track setup display.

■ Delete

When the [DEL.] LCD button is pressed DELETE will appear for tracks which contain data. Select DELETE via the corresponding LCD buttons while holding the [DEL.] button to delete all data in the corresponding tracks. The data is actually deleted when the [DEL.] LCD button is released.

■ Song Save/Delete

- Save This function saves the edited song to the disk.
- Delete This function deletes the specified song file from the disk.

Track Setting for Recording (Quick Recording)

The explanations here apply to step #5 on page 111.

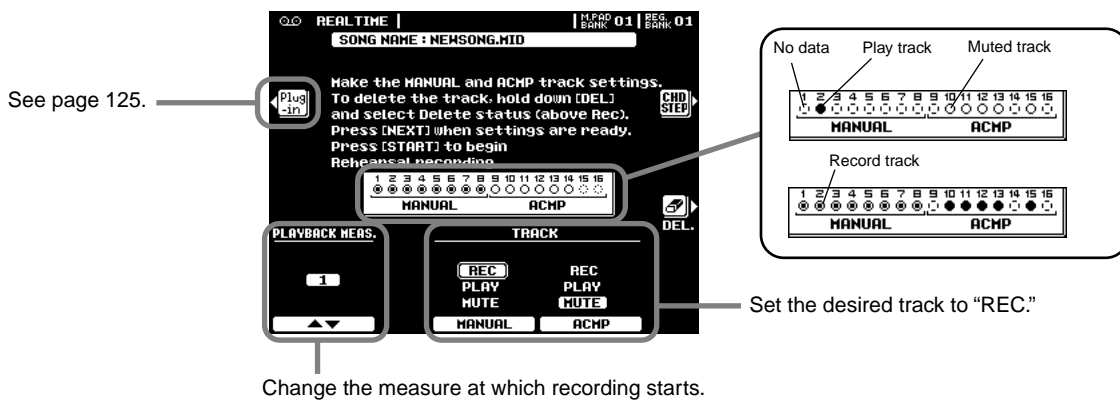

■ Delete

When the [DEL.] LCD button is pressed DELETE will appear for tracks which contain data. Select “DELETE” via the corresponding LCD buttons while holding the [DEL.] button to delete all data in the corresponding tracks. The data is actually deleted when the [DEL.] LCD button is released.

Song Edit Functions (Multi Track Recording)

The explanations here apply to step #6 on page 111.

■ Quantize

Quantize lets you “clean up” or “tighten” the timing of a previously recorded track.

For example, the following musical passage has been written with exact quarter-note and eighth-note values.



Even though you think you may have recorded the passage accurately, your actual performance may be slightly ahead of or behind the beat (or both!). Quantize allows you to align all the notes in a track so that the timing is absolutely accurate to the specified note value.

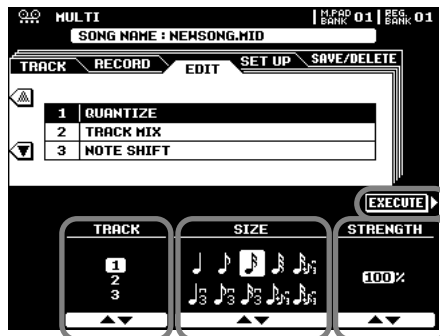

Press this to quantize the data.

This determines how “strongly” the notes will be quantized. If a value less than “100%” is selected, notes will be moved toward the specified quantization beats only by the specified amount.

Select the track to be quantized.

Select the Quantize size (resolution). See below for details.

● About Quantize size

Set the Quantize size to correspond to the smallest notes in the track you are working with. For example, if the data was recorded with both quarter notes and eighth notes, use 1/8 for the quantize value. If the quantize function is applied in this case with the value set to 1/4, the eighth notes would be moved on top of the quarter notes.

One measure of 8th notes before quantization



After quantization



The quantize sizes are :

1/4 note	1/8 note	1/16 note	1/32 note
1/16 note + 1/8 note triplet *	1/4 note triplet	1/8 note triplet	1/16 note triplet
1/8 note + 1/8 note triplet *	1/16 note + 1/16 note triplet *		

HINT

The three Quantize settings marked with asterisks (*) are exceptionally convenient, since they allow you to quantize two different note values at the same time, without compromising the quantization of either one. For example, if you have both straight 1/8 notes () and 1/8 note triplets () recorded to the same track, and you quantize to straight 1/8 notes (), all notes in the track are quantized to straight 1/8 notes — which completely eliminates any triplet feel in the rhythm! However, if you use the 1/8 note + 1/8 note triplet setting (), both the straight and triplet notes will be quantized correctly.

Track Mixing

This function allows data from two tracks can be mixed and the results placed in a different track, or data to be copied from one track to another.



Specify the tracks to be mixed.

Select the track into which the results will be placed.

To simply copy from the SOURCE1 track to the DESTINATION track select COPY via the SOURCE2 LCD buttons.

Press this to execute the Track Mix operation. After execution the this button changes to an UNDO button which can be used to undo the copy/mix operation if the results are not satisfactory (the "UNDO" button will only remain active until the next operation is performed).

NOTE

All data other than the mixed note data is derived from the SOURCE1 track.

NOTE

The Part Assign parameters of the Plug-in Voice are not copied to the destination part even if the Track Mix operation is executed. Therefore, set the Part Assign parameter (in the System Exclusive - XG parameters) to the corresponding Part number in the Event List display (page 120) after executing the Track Mix operation. For details about the Part Assign parameters, refer to the Owner's Manual of your Plug-in Board.

Note Shift

This allows tracks which contain data to be individually transposed up or down by a maximum of two octaves in semitone increments.

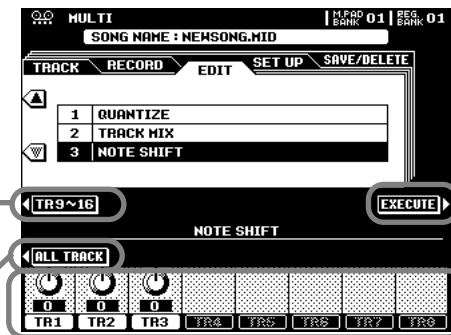

The TR1-8/TR9-16 LCD button can be used to switch between tracks 1 through 8 and tracks 9 through 16.

Adjust any track while holding this button to set the note shift for all tracks simultaneously.

Set the desired amount of transposition for each track (note-shift controls will only appear for tracks which contain data).

Press this to execute the Note Shift operation. After execution this button changes to an UNDO button which can be used to undo the Note Shift operation if the results are not satisfactory (the "UNDO" button will only remain active until the next operation is performed).

Song Setup (Multi Track Recording)

This function lets you assign the DSP effect block (4~7) to any of the current song's tracks. Other parameters can be modified up as required via the MIXING CONSOLE display (page 144).

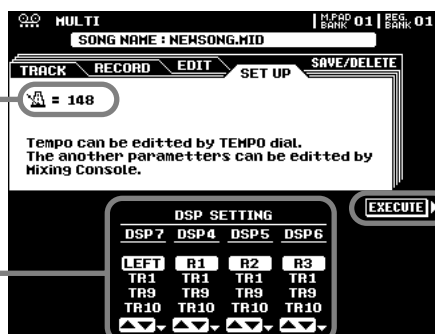

The tempo of the song can be set as required via the Data dial, and all other available parameters can be modified as required via the MIXING CONSOLE displays.

Assign the DSP effect block (4~7) to any of the current song's tracks.

Press this to record the settings to the current song.

NOTE

Only one of the Setup parameters can be recorded to each track, and any parameter changes made in the middle of the song will be cancelled. However, in the case of Volume and Tempo data, any Volume and Tempo changes in the middle of the song are applied as an offset to the initial Setup Data setting.

Step Recording (Multi Track Recording)

The Step Recording feature makes it possible to record notes with absolutely precise timing.

The explanations here apply to step #5 on page 111.

■ Entering the Note Event

This section explains how to step-record notes, using three specific examples.

• Example 1



1 Call up the Step Recording display by pressing the [STEP REC] button.

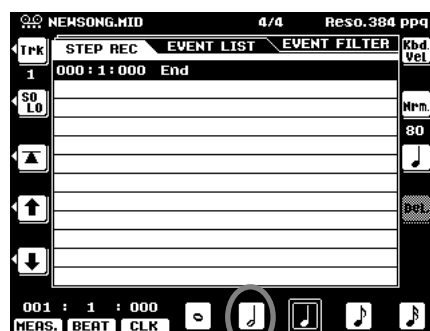

Make sure this is selected.

2 Play the keys C, D, E, F, G, A, B and C in order.

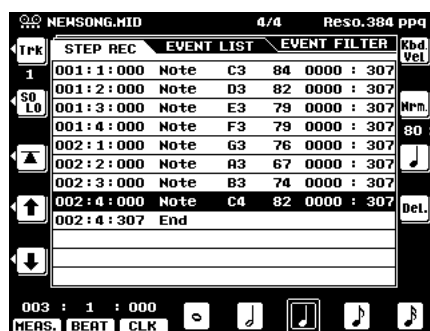
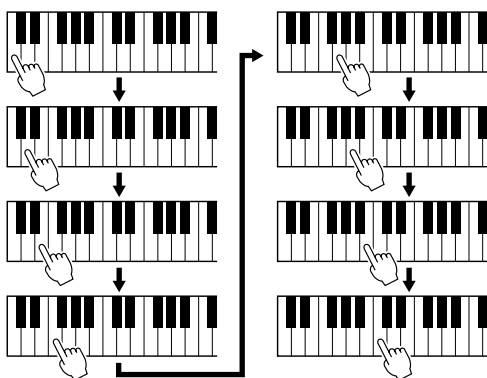

3 Press the [START/STOP] button to hear your newly recorded notes.



• Example 2

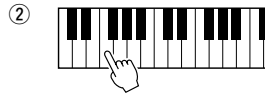
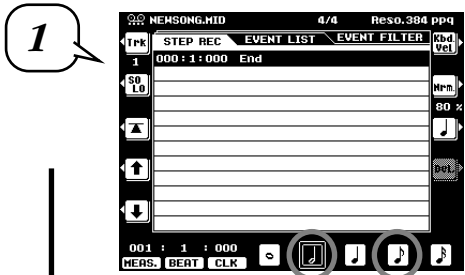

③ Press this while holding F.
① Select this resolution.

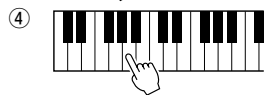
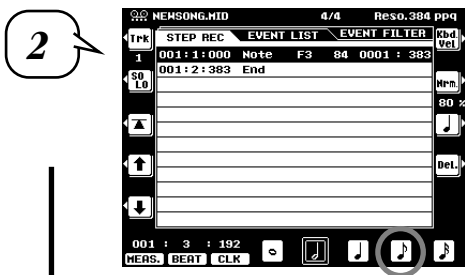

① Select this resolution.

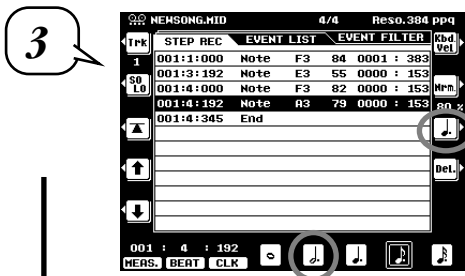

① Press this button, repeatedly if necessary, to enable the dotted note selectors at the bottom of the display. (Pressing the button alternately switches the note selectors among three basic note values: normal, dotted and triplet.)

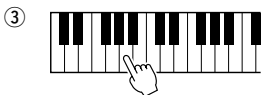

② Select this resolution.

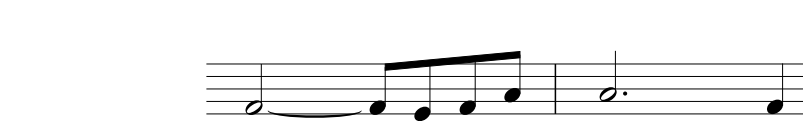
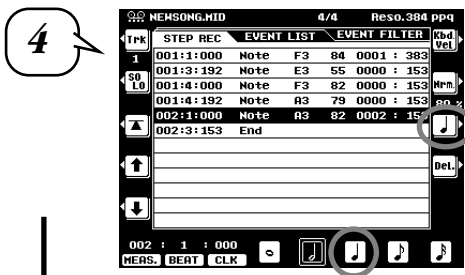

① Press this button, repeatedly if necessary, to re-enable the normal note selectors.



② Select this resolution.

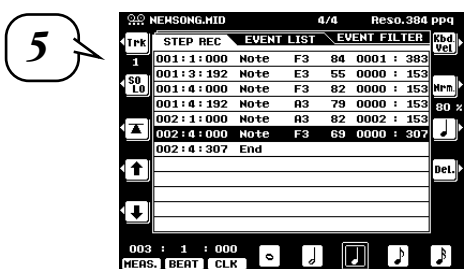

Press the [START/STOP] button to move the cursor to the beginning of the song and press the [START/STOP] button to hear your newly recorded notes.

• Example 3



1

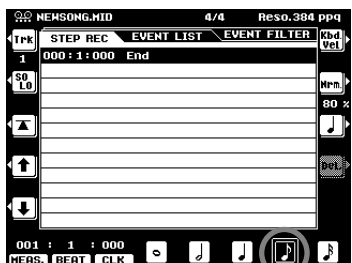

2



Press and hold C3.



① Select this resolution. ③ Press this again while holding C3.

2

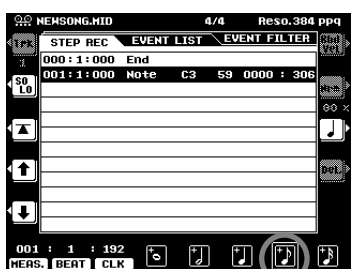

1



Press and hold C3 and E3.



② Press this while holding C3 and E3.

3

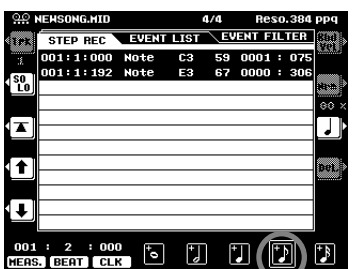

1



Press and hold C3, E3 and G3.



② Press this while holding C3, E3 and G3.

4

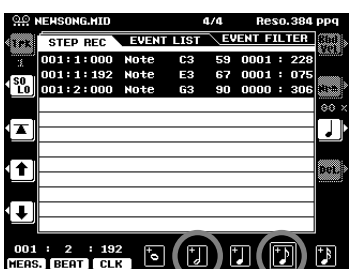

1



Press and hold C3, E3, G3 and C4.



② Press this while holding C3, E3, G3 and C4.

③ Press this while holding C3, E3, G3 and C4, and release the four keys.

5

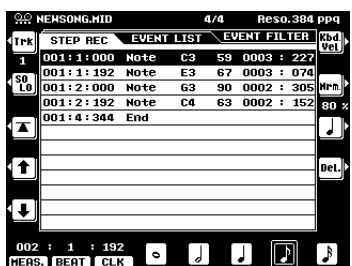

Press the [START/STOP] button to move the cursor to the beginning of the song and press the [START/STOP] button to hear your newly recorded notes.

The functions of each menu item in the display are explained below.

When this is set to on (highlighted), you can play only the currently displayed track.

Select the track to be recorded.

This specifies the velocity for the next note to be entered. See "Velocity settings" below.

This sets the note length (time that the note is actually sounded), as a percentage of the step time. See "Gate time settings" below.

Pressing the button alternately switches the note selectors (at the bottom of the display) among three basic note values: normal, dotted and triplet..

Press this to actually delete the event at the current cursor position.

The "size" of the current recording step time for the next note to be entered. This determines to what position the pointer will advance after a note has been entered.

This shows the current position at which you enter the note.
 Clock: 384 clocks per 1/4-note.
 Beat: 1 - 4 (for 4/4 time)
 Measure number

Moves the cursor up/down.

Instantly returns to the first beginning of the current recorded song (i.e. the first beat of the first measure).

● About Measure/Beat/Clock

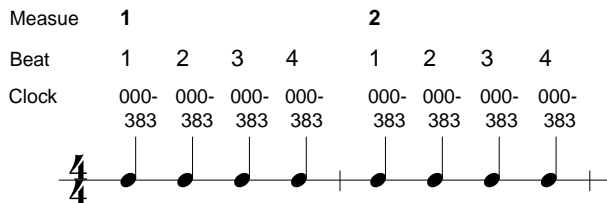

● Velocity settings

The following parameters are available.

- Kbd. Vel When this is selected, the strength at which you play the keyboard determines the recorded velocity values.
- fff The velocity of the entered note is set to 127.
- ff The velocity of the entered note is set to 111.
- f The velocity of the entered note is set to 95.
- mf The velocity of the entered note is set to 79.
- mp The velocity of the entered note is set to 63.
- p The velocity of the entered note is set to 47.
- pp The velocity of the entered note is set to 33.
- ppp The velocity of the entered note is set to 15.

● Gate time settings

The following parameters are available.

- Normal 80%
- Tenuto 100%
- Staccato 40%
- Staccatissimo.. 20%
- Manual When this is selected, you can specify the Gate time as a percentage manually.

■ Entering other events (Event List)

In addition to Note on/off, the following events can be recorded in the Event List display.

● Conductor Track:

- Tempo
- Time Signature
- End Mark
- System Exclusive (XG parameters)
- System Exclusive (others) *
- Meta Event *

* These are displayed only and cannot be edited.

● Tracks 1 through 16:

- Note on/off Messages which are generated when the keyboard is played. Each message includes a specific note number which corresponds to the key which is pressed, plus a velocity value based on how hard the key is played.
- Control Change..... Controller settings such as volume, pan (edited via the Mixing Console), etc.
- Program Change..... Voice selecting
- Pitch Bend Bends the pitch of notes up or down.
- Channel Aftertouch Applies aftertouch to all notes.
- Polyphonic Aftertouch..... Applies aftertouch to a single note.

When this is set to on (highlighted), you can play only the current recorded track.

Select the track to be edited.

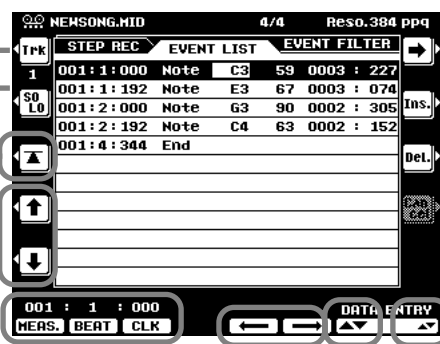

Press this to add a new event to the Event List.

Press this to actually delete the event at the current cursor position.

If the value at the cursor has been changed, pressing this restores the original value.

Adjust the event value finely.

Adjust the event value coarsely.

Moves the cursor leftward/rightward. Keep in mind that moving the cursor away from the just-edited value automatically enters that value.

This shows the current position at which you edit the event.

Clock: 384 clocks per 1/4-note.
Beat: 1 - 4 (for 4/4 time)
Measure number

Moves the cursor upward/downward. Keep in mind that moving the cursor away from the just-edited value automatically enters that value.

Instantly returns to the first beginning of the current recorded song (i.e. the first beat of the first measure).

NOTE

- To actually enter an edited value, move the cursor away from the value or press the [START/STOP] button to start playback.

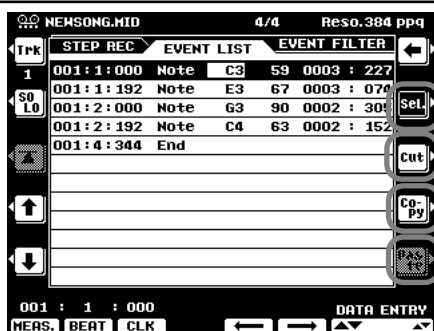

Determines the method of event selection: single or multiple.

Press this to cut all the selected events and copy them to the clipboard.

Press this to copy all the selected events to the clipboard.

Press this to paste all the event data that is currently contained in the clipboard.

■ About Multiple Event Selection

This convenient feature lets you select several events together, making it possible to change the values of many different events at once, or easily and quickly copy many events to another location.

• Changing the values of multiple events

In the example explanation below, we'll increase the velocity of the selected note data by 20.

- ① Using the [**▲**] button, move the cursor to the first event at the top of Event List, and select the velocity value.
- ② Press the [SEL] button to enable multiple event selection.
- ③ Use the [**▼**] button to determine the range to be selected. Each successive event that you scroll through in this way is selected.
- ④ Use the data dial to change the value. All values for the selected events are changed simultaneously.
- ⑤ To actually enter the changes, press the [SEL] button again to return to single event selection.

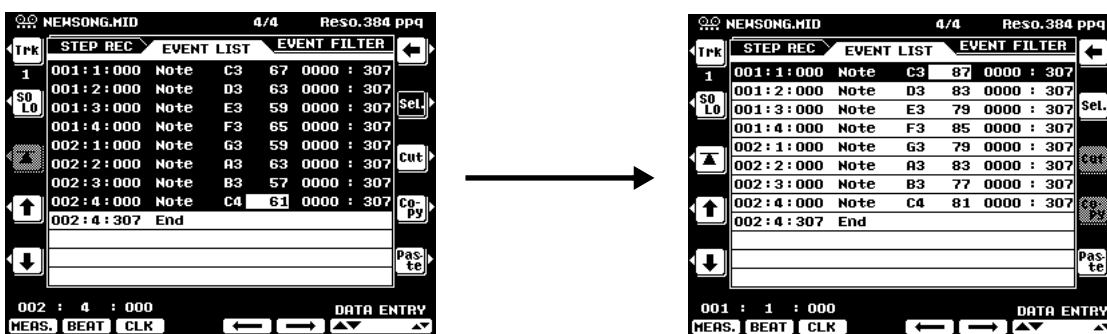

• Copying and pasting multiple events

In the example explanation below, we'll copy the events of the second measure in song data and paste them to the third measure.



- ① Use the [**▼**] or [**▲**] buttons to move the cursor to the beginning of the second measure.
- ② Press the [SEL] button to enable multiple event selection.
- ③ Use the [**▼**] button to determine the range to be selected. For this example, scroll to the last event in the measure so that all events in measure 2 are selected.
- ④ Press the [COPY] button.
- ⑤ Press the [SEL] button to change to single event selection.
- ⑥ Set the destination (the top of measure 3, in this case) by using the [MEAS], [BEAT] and [CLK] buttons.
- ⑦ Press the [PASTE] button.

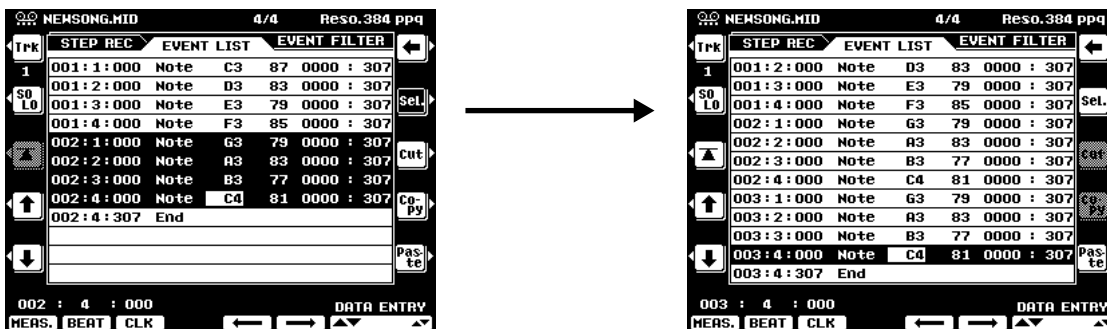

The diagram below illustrates how the 9000Pro handles the copy/paste operation.

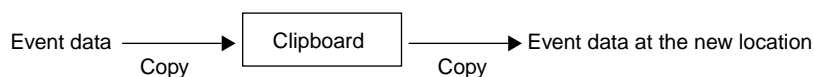

The clipboard is a temporary “holding place” for the copied data (as done in Steps #3 and #4 above). Once the data is in the clipboard, and as long as no other data has been copied there, the data can be pasted to other locations — as many times as desired. Keep in mind that copying data automatically erases whatever data was originally in the clipboard. (The data at the original location in the song remains intact.)

Event Filter

This function lets you select the event types that appear on the editing displays. To select an event for display, place a checkmark in the box next to the event name. To filter out an event type (so that it does not appear on the list), remove the checkmark so that the box is empty. See below for details.

Chord Step (Quick Recording)

The Chord Step recording feature makes it possible to record Auto Accompaniment chord (page 70) changes one at a time with precise timing. Since the changes don't have to be entered in real time, it is easy to create even complex chord changes and accompaniment before recording the melody.

The explanations here apply to step #6 on page 111.

Entering the Chord/Section (Chord Step)

For example, the following chord progression can be entered by the procedure described below.

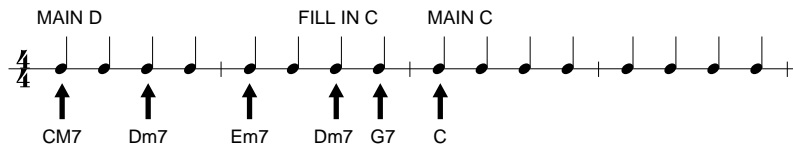

1 Press the [MAIN D] button to specify the section and enter the chords as shown at right.

ACCOMPANIMENT CONTROL: A, B, C, D (MAIN VARIATION)

NEMSONG.MID 4/4 Reso.2 ppq

STEP REC	EVENT LIST	EVENT FILTER
001:1:000	Sty P1 01	Heart Beat
001:1:000	Sect M D	Main D : 4
001:1:000	Chord C	CC
001:1:000	Tempo	148
003:1:000	End	

Select this resolution and play chords as shown at right.

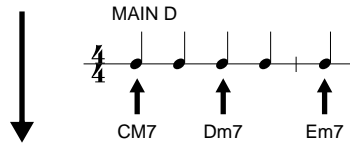

2 Press the [FILL] button to specify the section "FILL IN C" and enter the chords as shown at right.

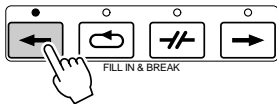

STEP	REC	EVENT LIST	EVENT FILTER
001:1:000	Sty	P1 01	Heart Beat
001:1:000	Sect	M D	Main D : 4
001:1:000	Chord	C M7	
001:1:000	Tempo	148	
001:3:000	Chord	D m7	
002:1:000	Chord	E m7	
002:3:000	Sect	F C	Fill In C : 1
004:1:000	End		

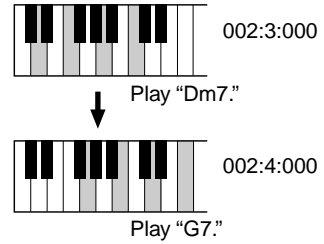

Select this resolution and play chords as shown at right.

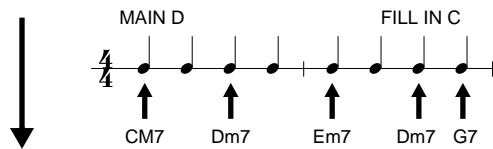

3 The [MAIN C] section is automatically selected.

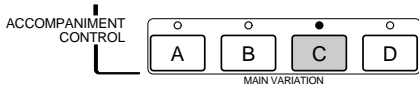

STEP	REC	EVENT LIST	EVENT FILTER
001:1:000	Sty	P1 01	Heart Beat
001:1:000	Sect	M D	Main D : 4
001:1:000	Chord	C M7	
001:1:000	Tempo	148	
001:3:000	Chord	D m7	
002:1:000	Chord	E m7	
002:3:000	Chord	D m7	
002:3:000	Sect	F C	Fill In C : 1
002:4:000	Chord	G 7	
003:1:000	Sect	M C	Main C : 4
004:1:000	End		

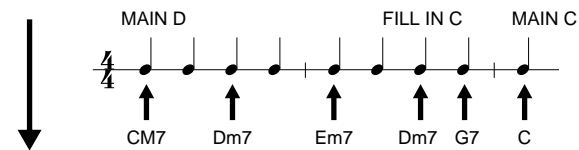
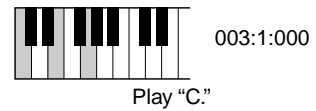

4

STEP	REC	EVENT LIST	EVENT FILTER
001:1:000	Sty	P1 01	Heart Beat
001:1:000	Sect	M D	Main D : 4
001:1:000	Chord	C M7	
001:1:000	Tempo	148	
001:3:000	Chord	D m7	
002:1:000	Sect	F C	Fill In C : 1
002:1:000	Chord	E m7	
002:3:000	Chord	D m7	
002:4:000	Chord	G 7	
003:1:000	Chord	C	
003:1:000	Sect	M C	Main C : 4
005:1:000	End		



Press the [START/STOP] button to move the cursor to the beginning of the song and press the [START/STOP] button to hear the Auto Accompaniment performance of your newly recorded data.

“END MARK” is shown in the display, indicating the end of the song data. The End Mark position for Chord Step is automatically determined according to the section that is input at the end of the song.

- Intro..... The End Mark is automatically recorded to a point following the Intro data (however many measures it is from the position of the last input to the end of the Intro data).
- Main The End Mark is automatically recorded two measures following the position of the last input.
- Fill The End Mark is automatically recorded one measure following the position of the last input.
- Ending..... The End Mark is automatically recorded to a point following the Ending data (however many measures it is from the position of the last input to the end of the Ending data).

The End Mark can be freely set to any position desired, if the automatically assigned position doesn't suit you.

The functions of each menu item in the display are explained below.

Instantly returns to the beginning of the current recorded song (i.e. the first beat of the first measure).

Moves the cursor upward/downward.

Press this to actually delete the event at the current cursor position.

The "size" of the current recording step. This determines to what position the pointer will advance after a chord has been entered.

This shows the current position at which you enter the chord.
 Clock: 384 clocks per 1/4-note (selectable 000 or 192)
 Beat: 1 - 4 (for 4/4 time)
 Measure number

STEP REC	EVENT LIST	EVENT FILTER
001 : 1 : 000	Sty P1 01	Heart Beat
001 : 1 : 000	Sect M D	Main D : 4
001 : 1 : 000	Chord C	M7
001 : 1 : 000	Tempo	148
001 : 3 : 000	Chord D	m7
002 : 1 : 000	Sect F C	Fill In C : 1
002 : 1 : 000	Chord E	m7
002 : 3 : 000	Chord D	m7
002 : 4 : 000	Chord G	?
003 : 1 : 000	Chord C	
003 : 1 : 000	Sect H C	Main C : 4
005 : 1 : 000	End	

■ Entering other events (Event List)

In addition to the Chord/Section, the following events can be recorded in the Event List display. All menu items in the display are the same as in Step Recording (page 120).

- Tempo
- Accompaniment Volume
- Accompaniment Part Volume
- Accompaniment Part on/off
- Style number
- Section
- Chord

STEP REC	EVENT LIST	EVENT FILTER
001 : 1 : 000	Sty P1 01	Heart Beat
001 : 1 : 000	Sect M D	Main D : 4
001 : 1 : 000	Chord C	M7
001 : 1 : 000	Tempo	148
001 : 3 : 000	Chord C	M7
002 : 1 : 000	Sect F C	Fill In C : 1
002 : 1 : 000	Chord E	m7
002 : 3 : 000	Chord D	m7
002 : 4 : 000	Chord E	m7
003 : 1 : 000	Chord C	
003 : 1 : 000	Sect H C	Main C : 4
005 : 1 : 000	End	

001 : 3 : 000 DATA ENTRY
 MEAS. BEAT CLK

■ Event Filter

This function lets you select the event types that appear on the editing displays. To select an event for display, place a checkmark in the box next to the event name. To filter out an event type (so that it does not appear on the list), remove the checkmark so that the box is empty.

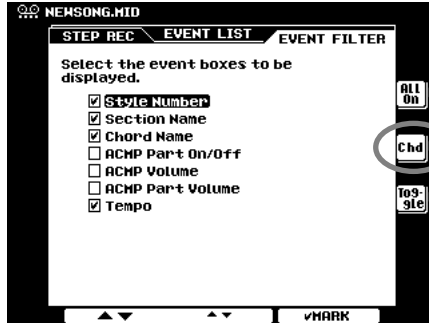

Selects only chord data; checkmarks for all other boxes are removed.

NOTE
 • Style Number, Section Name, Chord Name, and Tempo are on (checked) by default.

Using the Plug-in voices in Song Creator

Keep in mind that a single Plug-in Board can only sound one part (one Plug-in voice) at a time. For this reason, you may run into the following problems when using certain Song Creator functions with the Plug-in voices:

● When you stop recording (step #9 on pages 37 and 39), with a Plug-in voice:

For example, when recording the R1 voice (when that is assigned to a Plug-in voice), the R1 part button automatically turns off when the [STOP] button is pressed. This happens in order that the you can hear the recorded song properly with the Plug-in Voice (step #10 on pages 37 and 39).

When you stop recording, the connection with the Plug-in Board automatically switches to the Song Creator.

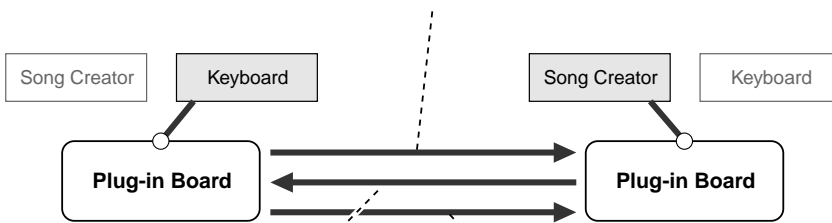

The connection with the Plug-in Board can be switched to the keyboard part by pressing the PART ON/OFF button.



The connection with the Plug-in Board can be switched to the Song part by pressing the [Plug-in] LCD button.



● When you use the Song Player to play back a song recorded with the Plug-in voices:

If any one of the parts of the Plug-in voice (R1, R2, R3, or L) is set to ON, the part in the song corresponding to the Plug-in voice will automatically be muted. Therefore, if you want to properly play back a song using Plug-in voices, make sure that the corresponding parts (R1, R2, R3, or L) are set to OFF before selecting the song.

NOTE
 • The explanations above apply only to the Song Creator and Song Player functions. They do not apply to the Style Creator and Multi Pad Creator, since the Plug-in voices cannot be used with those functions.

Style Creator

The 9000Pro lets you create original styles which can be used for auto accompaniment in the same way as the preset styles.

Guidelines for Style Creating

When creating a song (page 110), you record your keyboard performance to the 9000Pro as MIDI data. Creating of styles, however, is done in a different way.

The Style Creator provides two basic ways: assembling and recording.

■ Assembling styles Page 129

The Style Creator provides two basic ways to assemble styles:

● Easy Edit

This method lets you assemble styles based on the preset/flash style that is most similar to the style you wish to create.

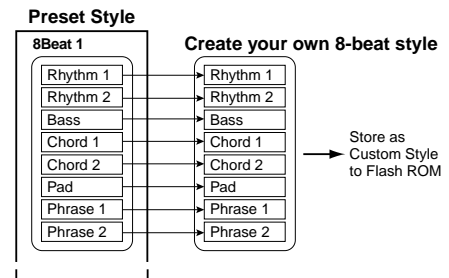

● New Style Assembly

The 9000Pro allows you to create “composite” styles by combining various patterns from the internal Preset and Flash styles.

For example, in creating your own 8-beat style, you could take the rhythm pattern from the “8 Beat 1” style, use the bass pattern from the “8 Beat 2” style, and take the chord pattern from the “Pop Rock” style — combining the various elements to create one style.

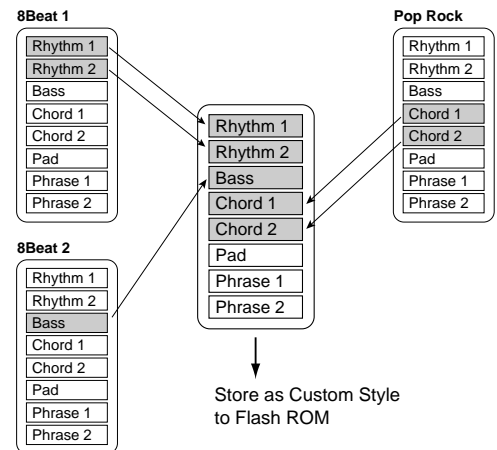

■ Recording styles (Full Edit page 132)

When recording a song, you record your keyboard performance to the 9000Pro as MIDI data. Recording styles, however, is done in a different way. Here are some of the aspects in which style recording differs from song recording:

● Using Preset Styles

As shown in the chart at right, when you select the preset/flash style that is the closest to the type of style you wish to create, the preset style data will be copied to a special memory location for recording.

You create (record) your new, original style by adding or deleting data from the memory location. All parts (with the exception of the rhythm track) of preset styles must be cleared before recording (page 133).

● Loop Recording

Auto accompaniment repeats the accompaniment patterns of several measures in a “loop,” and style recording is also done using loops. For example, if you start recording with a two-measure main section, the two measures are repeatedly recorded. Notes that you record will play back from the next repetition (loop), letting you record while hearing previously recorded material.

● Overdub Recording

This method records new material to a track already containing recorded data, without deleting the original data. In style recording, the recorded data is not deleted, except when using functions such as Clear and Drum Cancel (page 132).

For example, if you start recording with a two-measure main section, the two measures are repeated many times. Notes that you record will play back from the next repetition, letting you overdub new material to the loop while hearing previously recorded material.

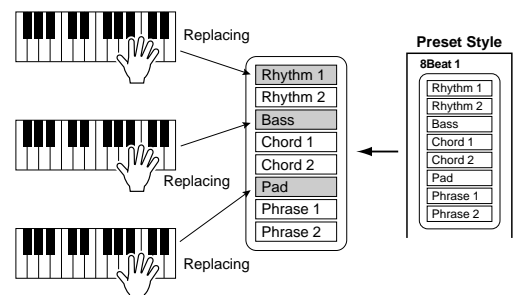

The following functions are also available:

- RevoiceDetermines the basic volume, tempo, and Part on/off settings for your original style.
- Groove & DynamicsThis gives you a comprehensive variety of tools for changing the rhythmic "feel" of your original style. Specifically, it allows you to alter the timing for each section and velocity of notes for each track.
- SetupThis can be used to change the voices assigned to any of the current selected section/part.
- Edit.....The six editing features that contain "Quantize" allow you to edit already recorded style data.
- Parameter Edit.....Determines various parameters of the Style File Format. See below for details about Style File Format.

■ Style File Format

The Style File Format (SFF) combines all of Yamaha's auto accompaniment know-how into a single unified format. By using the Parameter Edit function, you can take advantage of the power of the SFF format and freely create your own styles.

The chart below indicates the process by which the accompaniment is played back. (This does not apply to the rhythm track.)

The source pattern in the chart is the original style data. As explained on page 132, in style recording this source pattern is recorded.

As shown in the chart below, the actual output of the accompaniment is determined by various parameter settings and chord changes (playing chords in the auto accompaniment section of the keyboard) entered to this source pattern.

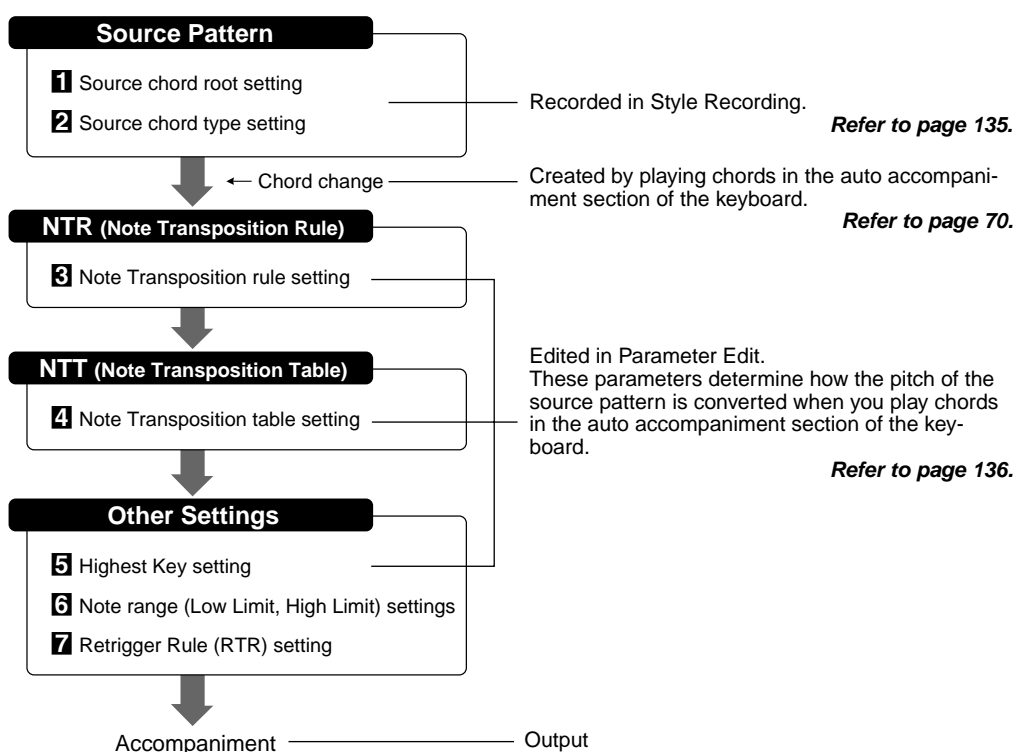

NOTE

Since newly created style data is stored to Flash ROM, any pre-programmed data in the selected style location will be erased and replaced by your new settings. This includes the factory programmed Flash style data (Flash styles I through VIII). If you've deleted the factory-set data, you can use the Restore function (page 154) to load a copy of it from the included disks (page 6).

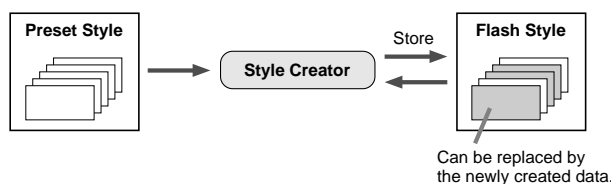

For details about Flash ROM, refer to "Memory Structure" on page 54.

Basic Procedure

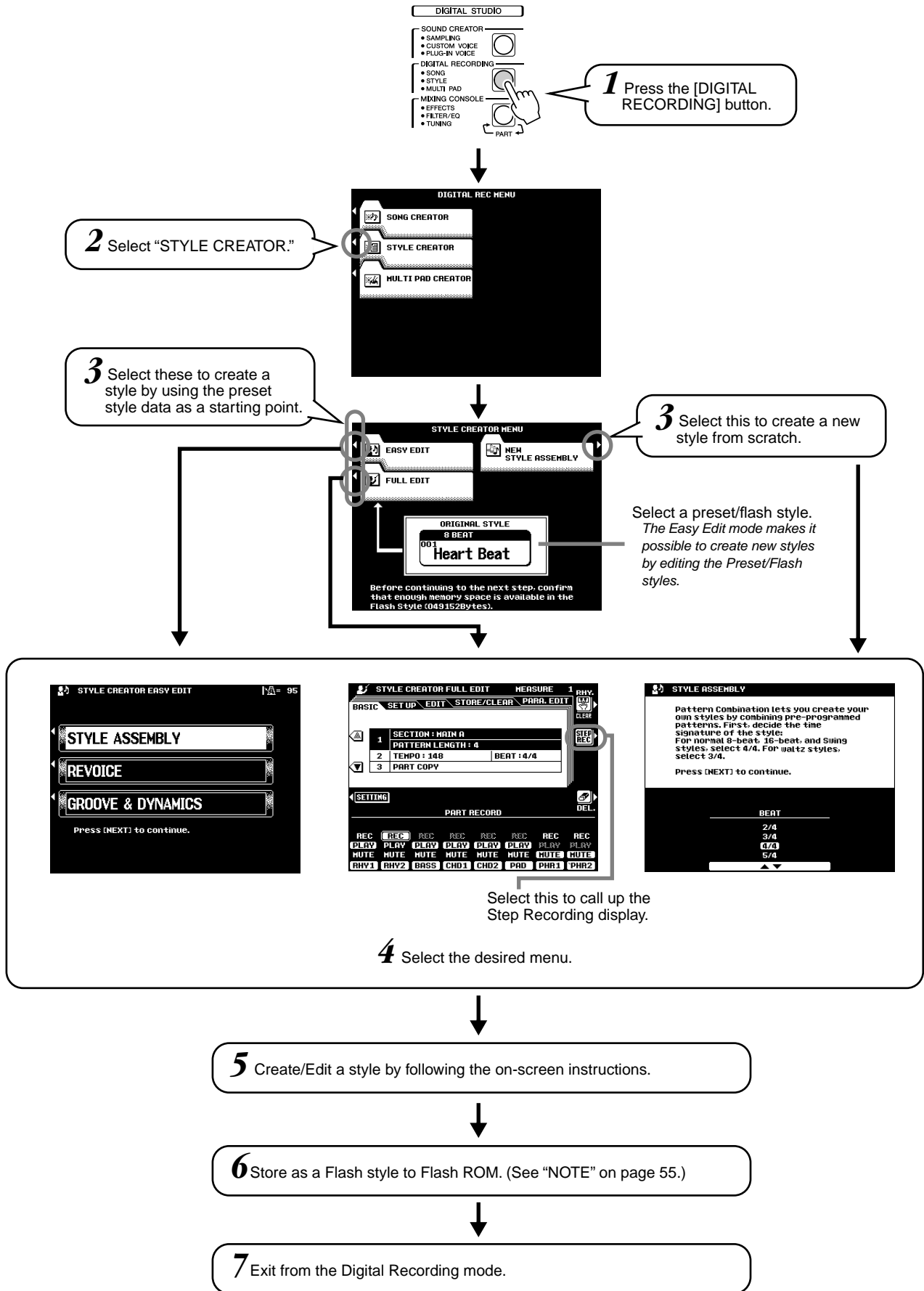

Style Assembly — Creating a Style

This operation lets you create the patterns (rhythm, bass and chords) that will make up your original style.

The explanations here apply to step #5 of the Basic Procedure on page 128.

● Set up for creating a style.

Select the section you want to create, and set the length (in bars) of the Pattern. Generally, this will be 2 bars or 4 bars. Press [NEXT] to continue.

SECTION: MAIN A, MAIN B, MAIN C, MAIN D

PATTERN LENGTH: 1, 2, 3, 4

Set the Pattern Length of the selected section.

Select a section to be created.

PAGE CONTROL: BACK, NEXT

NOTE

- The length in measures for all sections (excepting Fill In and Break) can be set from this display. The Fill In and Break sections are limited to one measure.
- You can return to this display by pressing the [BACK] button and redo the settings.

● Assign the pattern for each track.

Indicates the selected track.

Select a pattern for RHYTHM1. Using Category, Style, Section and Part, you can access all of the pre-programmed patterns. Press [START] to audition the pattern. Play Type lets you solo or mute the current pattern. Press [NEXT] to continue.

CATEGORY	STYLE	SECTION	PART	PLAY TYPE
8 Beat	Hear4 Beat	MAIN A	RHV1	SOLO
16 Beat	8Beat 1	MAIN B	RHV2	PLAY
DANCE	8Beat 2	MAIN C	CHV1	MUTE
SHINGS:JAZZ	8Beat 3	MAIN D	CHV2	

Select a play type.

SOLO	Mutes (turns off) all other tracks.
PLAY	Turns the selected track on.
MUTE	Mutes (turns off) the selected track.

Select a style, section and part to be assembled.

[BACK] [NEXT]

NOTE

- Keep in mind that any track data for which the Play Type is set to "MUTE" is not stored to Flash ROM.

RHYTHM 2

BASS

Phrase2

[NEXT] [BACK]

[BACK] [NEXT]

● Store as a Flash style to Flash ROM by following the on-screen instructions.

Revoice (Easy Edit)

The Revoice parameters let you determine the basic volume, tempo, and Part on/off settings for your original style.

The explanations here apply to step #5 of the Basic Procedure on page 128.

● **Select the Style and the Section to be revoiced.**

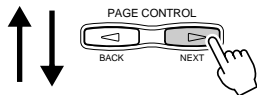
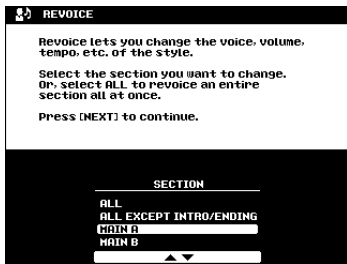

● **Edit the Revoice parameters.**

The 9000Pro Revoice function lets you change the following parameters for each track.

- Total Volume, Tempo
- Voice number
- Part Volume
- Part on/off

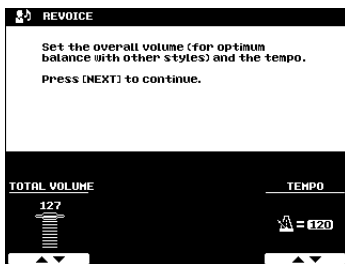

NOTE

- Keep in mind that any track data which is set to off is not stored to Flash ROM.

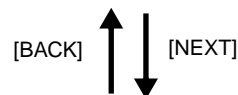
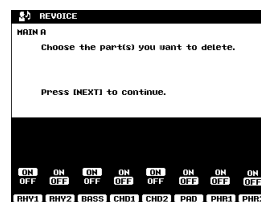
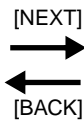
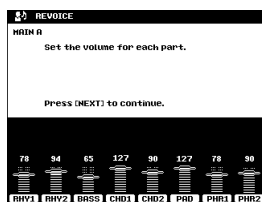
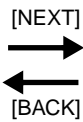
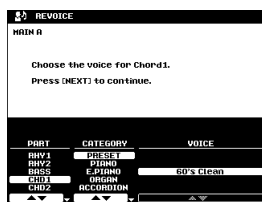

● **Store as a Flash style to Flash ROM by following the on-screen instructions.**

Groove & Dynamics (Easy Edit)

The Groove and Dynamics parameters give you a comprehensive variety of tools for changing the rhythmic “feel” of your original style.

The explanations here apply to step #5 of the Basic Procedure on page 128.

● Select the Style and the Section.

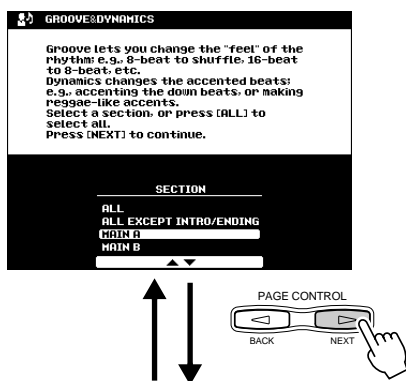

● Edit the Groove parameters.

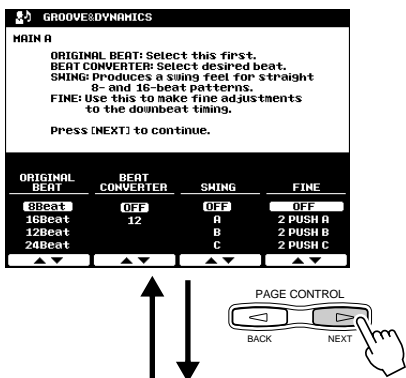

● Edit the Dynamics parameters.

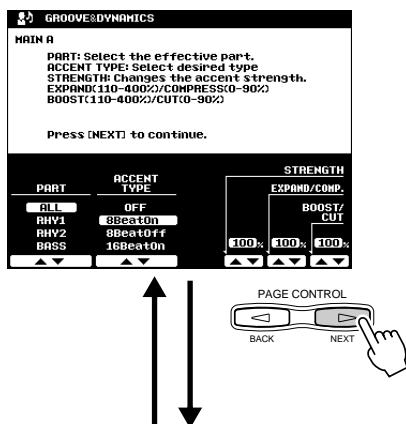

● Store as a Flash style to Flash ROM by following the on-screen instructions.

Groove parameters

Beat	Specifies the beats to which groove timing is to be applied (i.e., if “8” is selected, groove timing is applied to 8th notes in the selected section; or if “12” is selected groove timing is applied to 8th-note triplets).
Beat Converter	Actually changes the timing of the beats specified by the Beat to the specified value. The available Beat Converter settings change according to the selected Beat. With a Beat setting of “8” and a Beat Converter setting of “12”, for example, all 8th notes in the section are shifted to 8th-note triplet timing. The “16A” and “16B” Beat Converter settings which appear when Beat is set to “12” are variations of the “16” setting.
Swing	Produces a “swing” feel by shifting the timing of “back beats,” as specified by the Beat parameter. For example, if the specified Beat value is 8th notes, then the swing parameter will delay the 2nd, 4th, 6th, and 8th beats of each measure to create a swing feel. The “A” through “E” settings produce different degrees of swing feel, with “A” being the most subtle and “E” being the strongest.
Fine	Selects a range of “groove templates” to be applied to the current section. “PUSH” settings cause certain beats to be played early, while “HEAVY” settings delay the timing of certain beats. The number — “2”, “3”, “4”, or “5” — determines which beats are to be affected. All beats up to the specified beat, but not including the first beat, will be played early or delayed: e.g., the 2nd and 3rd beats if “3” is selected. In all cases “A” types produce minimum effect, “B” types produce medium effect, and “C” types produce the maximum effect.

Dynamics parameters

Accent Type	Selects the type of accent template to be applied to the selected section/part.
Strength	Determines how “strongly” the selected Accent Type will be applied. Higher values produce a stronger effect.
Expand/Compression	Expands or compresses the range of velocity values in the selected section, based on a “central” velocity value of “64.” Values higher than 100% expand the dynamic range, and values lower than 100% compress the dynamic range.
Boost/Cut	Boosts or cuts all velocity values in the selected section/part. Values above 100% boost the overall velocity and values below 100% reduce the overall velocity.

Style Recording (Full Edit)

This section explains how to record all parts by playing the keyboard. The explanations here apply to step #5 of the Basic Procedure on page 128.

Basic Setting for Recording

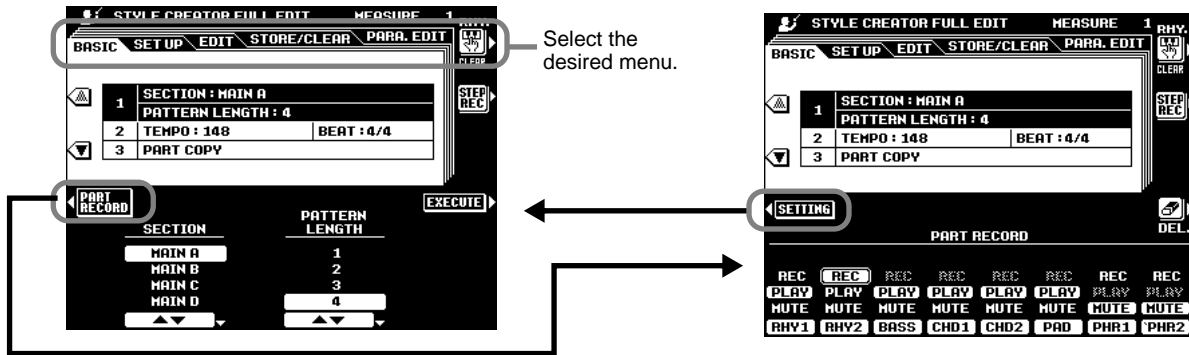

- Section Select the section you want to program.
- Pattern Length Select the desired number of measures (1-32) for the selected section (except for FILL IN sections, which are fixed at 1 measure).
- Beat Select a different time signature: 2/4, 3/4, 4/4, or 5/4. Please note that the time signature can only be changed if all sections of the current style have been cleared. If any data remains in any section, the alert message will appear. A new time signature can be selected after clearing all sections of the current selected style.
- Tempo Set the default tempo for the new style.
- Part Copy Instead of starting with all the sections and/or parts from the selected original style, you can copy specific parts from other sections/parts of the same style, or from other styles as required.

Also, in some cases it may not be possible to copy from other parts. In such a case the EXECUTE LCD button will appear in gray and will not be available.

Style Recording – Rhythm Tracks

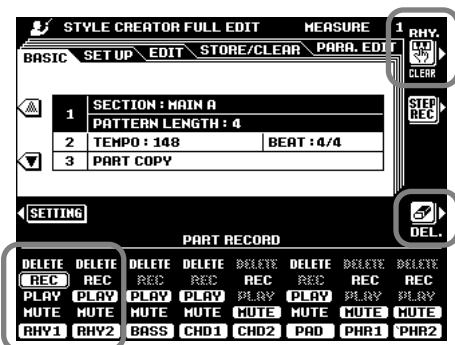

You can also delete certain percussion sounds while recording. While holding this button, press the key on the keyboard corresponding to the instrument you want to cancel.

When this button is pressed, DELETE will appear for parts which contain data. Set the desired part to "DELETE" while holding this button to delete all data in the corresponding parts. The data is actually deleted when this button is released.

NOTE

- Only DRUM KIT/SFX KIT and DRUM KIT custom voices can be selected for the RHY2 part.
- All voices except the ORGAN FLUTE voice can be selected for the RHY1 part.
- You can also start recording by pressing [SYNC START] button and playing a key on the keyboard.

1 Set one of Rhythm parts to "REC."

2 Press the [START/STOP] button to start recording.

The selected section of the current style will begin playing (only the metronome will sound if the rhythm parts have been cleared). The style will loop (play) continuously to allow convenient recording and overdubbing. Since the rhythm pattern plays back repeatedly, you can record by overdubbing — listening to the pattern and playing the desired keys. Look at the icons printed under the keys indicating the percussion sounds that are assigned to each key.



3 Press the [START/STOP] button again to stop recording.

■ Style Recording – Bass/Chord Tracks/Pad/Phrase

Recording of the bass, phrase, pad and chord tracks is unlike recording of the rhythm (drum) parts in that you have to clear the track data of the original style before recording.

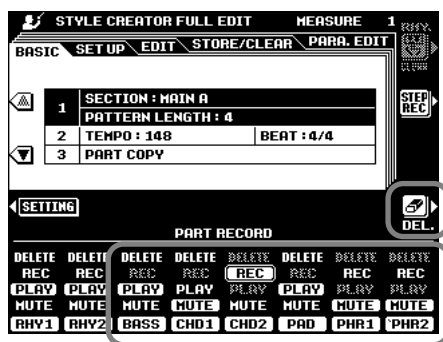

1 When this button is pressed, DELETE will appear for parts which contain data.

2 Set the desired part to "DELETE" while holding this button to delete all data in the corresponding parts. The data is actually deleted when this button is released.

3 Set the desired parts to "REC."

4 Start recording.

You can start recording with one of the following ways:

- Press the [START/STOP] button.
- Press the [SYNC START] button to enable synchronized standby (page 20), then play a key on the keyboard.

The recording repeats indefinitely (until stopped) in a loop. Notes that you record will play back from the next repetition, letting you record while hearing previously recorded material.

5 Stop recording.

NOTE

- The ORGAN FLUTES voices and DRUM KIT voices cannot be selected for these parts.

Observe the following rules when recording the MAIN and FILL sections:

- Use only the CM7 scale tones when recording the BASS and PHRASE tracks (i.e. C, D, E, G, A, and B).
- Use only the chord tones when recording the CHORD and PAD tracks (i.e. C, E, G, and B).

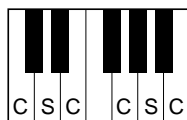

C = chord tone
C, S = scale tones

Any appropriate chord or chord progression can be used for the INTRO and ENDING sections.

The basic chord for the accompaniment is called the source chord. The default source chord is set as CM7, but you can change it to whatever chord is easy for you to play. For details, see "Style File (Auto Accompaniment) Format" (page 127) and "Parameter Edit" (page 135).

Style Editing (Full Edit)

This section explains various parameters, other than the basic ones. The explanations here apply to step #5 of the Basic Procedure on page 128.

■ Setup

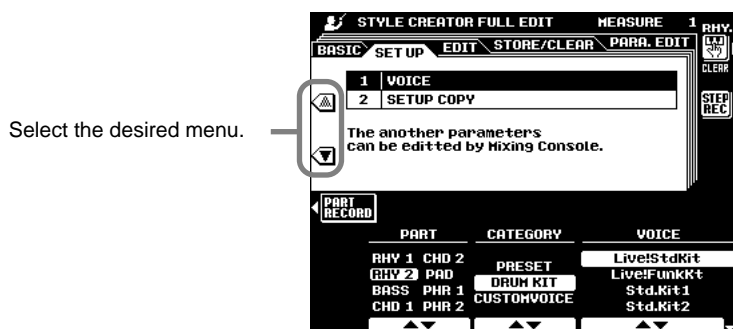

● Voice

This function can be used to change the voices assigned to any of the current style's parts. While the SETUP display is selected, all other available parameters can be modified as required via the MIXING CONSOLE displays.

● Setup Copy

Instead of starting with all the sections and/or parts from the selected original style, you can copy specific parts from other sections/parts of the same style, or from other styles as required.

■ Edit

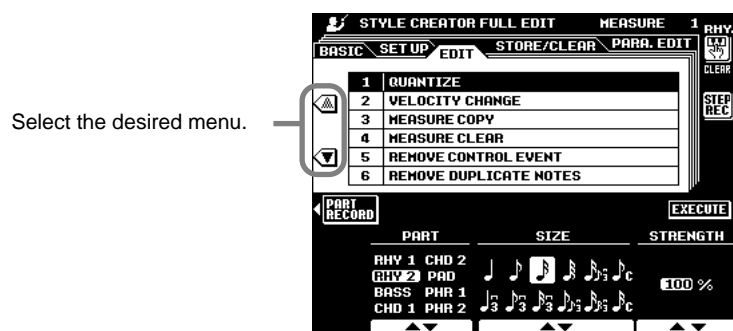

- Quantize Refer to page 114.
- Velocity Change Boosts or cuts the velocity of all notes in the specified part by the specified percentage.
- Measure Copy..... This function allows data to be copied from one measure or group of measures to another location within the same part. Use the TOP and LAST LCD buttons to specify the first and last measures in the region to be copied. Use the DEST LCD button to specify the top of the measure to which the data is to be copied. If the copy destination falls outside the number of measures actually in the part, the corresponding source measures will not be copied.
- Measure Clear This function clears all data from the specified range of measures within the specified part. Use the TOP and LAST LCD buttons to specify the first and last measures in the range to be cleared.
- Remove Control Event..... This function can be used to remove all occurrences of a specified type of control event from a specified part. Use the EVENT LCD buttons to select the type of event to be removed.
- Remove Duplicate Notes .. Removes all duplicate notes from a specified part.

Parameter Edit



Source Root/Source Chord

These settings determine the original key of the source pattern (i.e. the key used when recording the pattern). The default, CM7 (the source root is “C” and the source chord type is “M7”), is automatically selected whenever the preset data is deleted prior to recording a new style, regardless of the source root and chord included in the preset data.

When you change the chord of the source pattern from the default CM7 to others, the chord notes and scale notes will change depending on the currently selected chord type. See page 133 for information on chord notes and scale notes.

NOTE

- When NTR is set to ROOT FIXED and NTT (also above) is set to BYPASS, the SOURCE ROOT and SOURCE CHORD parameter names change to PLAY ROOT and PLAY CHORD. In this case it is possible to change chords and hear how the results sound for all parts.

[ex.] Source Chord Root of “C”

CM [Maj] 	CM6 [Maj6] 	CM7 [Maj7] 	CM7(#11) [M7#11] 	CM add9 [(9)]
C7(9) [M7(9)] 	C6(9) [6(9)] 	Caug [aug] 	Cm [min] 	Cm6 [min6]
Cm7 [min7] 	Cm7 b5 [m7b5] 	Cm(9) [m(9)] 	Cm7(9) [m7(9)] 	Cm7(11) [m7_11]
CmM7 [mM7] 	CmM7(9) [mM7_9] 	Cdim [dim] 	Cdim7 [dim7] 	C7 [7th]
C7sus4 [7sus4] 	C7 b5 [7b5] 	C7(9) [7(9)] 	C7(#11) [7#11] 	C7(13) [7(13)]
C7(b9) [7(b9)] 	C7(b13) [7b13] 	C7(#9) [7(#9)] 	CM7aug [M7aug] 	C7aug [7aug]
C1+8 [1+8] 	C1+5 [1+5] 	Csus4 [sus4] 	C1+2+5 [1+2+5] 	

● NTR (Note Transposition Rule)

Two settings are available:

- **ROOT TRANS**..... When the root note is transposed, the pitch relationship between notes is maintained. For example, the notes C3, E3, and G3 in the key of C will become F3, A3, and C4 when transposed to F. Use this setting for parts that contain melodic lines.



- **ROOT FIXED** The note is kept as close as possible to the previous note range. For example, the notes C3, E3, and G3 in the key of C will become C3, F3, and A3 when transposed to F. Use this setting for chordal parts.



● NTT (Note Transposition Table)

This sets the note transposition table to be used for source pattern transposition. Six table types are available:

- **BYPASS** No transposition.
- **MELODY** Suitable for melody line transposition. Use for melody parts such as PHRASE 1 and PHRASE 2.
- **CHORD** Suitable for chord transposition. Use for the CHORD 1 and CHORD 2 parts when they contain piano or guitar-like chordal parts.
- **BASS** Suitable for bass line transposition. This table is basically similar to the MELODY table, but recognizes “on-bass” chords allowed in the FINGERED 2 fingering mode. Use primarily for bass lines.
- **MELODIC MINOR** This table lowers the third scale degree by a semitone when changing from a major to a minor chord, or raises the minor third scale degree a semitone when changing from a minor to a major chord. Other notes are not changed.
- **HARMONIC MINOR** This table lowers the third and sixth scale degrees by a semitone when changing from a major to a minor chord, or raises the minor third and flattened sixth scale degrees a semitone when changing from a minor to a major chord. Other notes are not changed.

● Highest Key

This sets the highest key (upper limit of the octaves) of the note transposing for the Source Chord Root setting. The notes designated higher than the highest key will actually be played back in the octave just below the highest key.

This setting is effective only when the NTR parameter (above) is set to ROOT TRANS.

Example) When highest key is “F”.

Root change → CM C#M . . . FM F#M . . .
 Notes played → C3-E3-G3 C#3-F3-G#3 F3-A3-C4 F#2-A#2-C#3



● **Note Limit**

This sets the note range (low and high limits) for the voices recorded on user style tracks. By setting the note range, you can prevent unrealistic notes (such as high notes from a bass or low notes from a piccolo) from being produced and have them shifted to an octave within the note range.

Example: When low limit is “C3” and high limit is “D4.”

Root change → CM C#M . . . FM . . .

Notes played → E3-G3-C4 F3-G#3-C#4 F3-A3-C4

● **RTR**

This sets how notes held through chord changes will be handled. Six settings are available:

- Stop The note is stopped, and resumes sounding from the next note data.
- Pitch Shift..... The pitch of the note will bend without attack to match the type of the new chord.
- Pitch Shift To Root..... The pitch of the note will bend without attack to match the root of the new chord.
- Retrigger The note is retriggered with attack at a new pitch matching the new chord type.
- Retrigger To Root..... The note is retriggered with attack at a new pitch matching the new chord root.



Custom Style Recording via an External Sequence Recorder

You can create custom styles for the 9000Pro using an external sequencer (or personal computer with sequencing software), instead of using the 9000Pro's STYLE CREATOR function.

■ Connections

- Connect the 9000Pro MIDI OUT to the sequencer MIDI IN, and the sequencer MIDI OUT to the 9000Pro MIDI IN.
- Make sure that the sequencer "ECHO" function is ON, and the 9000Pro LOCAL ON/OFF (page 175) is turned OFF.

■ Creating the Data

- Record all sections and parts using a CM7 (C major seventh) chord.
- Record the parts on the MIDI channels listed below, using the 9000Pro's internal tone generator. Optimum compatibility with other instruments which are both XG and SFF (Style File Format) compatible can be achieved by using only the XG voices.

Part	MIDI Ch.
Rhythm1	9
Rhythm2	10
Bass	11
Chord1	12
Chord2	13
Pad	14
Phrase1	15
Phrase2	16

- Record the sections in the order listed below, with a Marker Meta-event at the top of each section. Enter the Marker Meta-events exactly as shown (including upper/lower case characters and spaces).
- Also include an "SFF1" Marker Meta-event, "SInt" Marker Meta-event and style name Meta-event at 1|1|000 (the top of the sequence track), and the GM on Sys/Ex message (F0, 7E, 7F, 09, 01, F7). ("Timing" in the chart is based on 480 clocks per quarter note. "1|1|000" is clock "0" of the first beat of the first measure).
- The data from 1|1|000 through 1|4|479 is the "Initial Setup", and 2|1|000 through the end of Ending B is the "Source Pattern".
- The timing of the Fill In AA and subsequent Marker Meta-events will depend on the length of each section.

Timing	Marker Meta-Event	Contents	Comments		
1 1 000 1 1 000	SFF1	Style Name (Sequence/Track Name Meta-Event) GM on Sys/Ex Initial Setup Events			
1 1 000 1 1 000 1 2 000 ⋮ 1 4 479	SInt				
2 1 000 ⋮ 3 4 479	Main A			2 bars Main Pattern (up to 255 bars)	Corresponds to MAIN A
4 1 000 ⋮ 4 4 479	Fill In AA			1 bar Fill In Pattern	Corresponds to FILL IN A
5 1 000 ⋮ 6 4 479	Intro A	2 bars Intro Pattern (up to 255 bars)	Corresponds to INTRO I		
7 1 000 ⋮ 8 4 479	Ending A	2 bars Intro Pattern (up to 255 bars)	Corresponds to ENDING I		
9 1 000 ⋮ 10 4 479	Main B	2 bars Intro Pattern (up to 255 bars)	Corresponds to MAIN B		
11 1 000 ⋮ 11 4 479	Fill In BA	1 bar Fill In Pattern	Corresponds to BREAK		
12 1 000 ⋮ 12 4 479	Fill In BB	1 bar Fill In Pattern	Corresponds to FILL IN B		
13 1 000 ⋮ 14 4 479	Intro B	2 bars Intro Pattern (up to 255 bars)	Corresponds to INTRO II		
15 1 000 ⋮ 16 4 479	Ending B	2 bars Intro Pattern (up to 255 bars)	Corresponds to ENDING II		
17 1 000 ⋮ 18 4 479	Main C	2 bars Main Pattern (up to 255 bars)	Corresponds to MAIN C		
19 1 000 ⋮ 19 4 479	Fill In CC	1 bar Fill In Pattern	Corresponds to FILL IN C		
20 1 000 ⋮ 21 4 479	Intro C	2 bars Intro Pattern (up to 255 bars)	Corresponds to INTRO III		
22 1 000 ⋮ 23 4 479	Ending C	2 bars Intro Pattern (up to 255 bars)	Corresponds to ENDING III		
24 1 000 ⋮ 25 4 479	Main D	2 bars Main Pattern (up to 255 bars)	Corresponds to MAIN D		
26 1 000 ⋮ 26 4 479	Fill In DD	1 bar Fill In Pattern	Corresponds to FILL IN D		

Initial Setup

Source Pattern

A template which is handy for creating style data is included on the supplied floppy disk (TEMP-PLATE.MID).

- The Initial Setup area from 1|2|000 through 1|4|479 is used for voice and effect settings. Do not include note event data.
- The Main A data begins at 2|1|000. Any number of measures from 1 to 255 can be used. All measures must have one of the following time signatures: 2/4, 3/4, 4/4, or 5/4.
- Fill In AA begins from the top of the measure following the last measure of the Main A pattern. In the chart this is 4|1|00, but this is only an example and the actual timing will depend on the length of Main A. Please note that all Fill Ins can be only 1 measure in length (refer to the Section/Length chart below).

Section	Length
Intro	255 measures max.
Main	255 measures max.
Fill In	1 measure
Ending	255 measures max.

- The following charts indicate the valid MIDI events for both the Initial Setup data and the Pattern data. Make sure to **NOT** enter any events marked with a dash (—), nor any events not listed here.

Channel Message

Event	Initial Setup	Source Pattern
Note Off	—	OK
Note On	—	OK
Program Change	OK	OK
Pitch Bend	OK	OK
Control#0 (Bank Select MSB)	OK	OK
Control#1 (Modulation)	OK	OK
Control#6 (Data Entry MSB)	OK	—
Control#7 (Master Volume)	OK	OK
Control#10 (Pan)	OK	OK
Control#11 (Expression)	OK	OK
Control#32 (Bank Select LSB)	OK	OK
Control#38 (Data Entry LSB)	OK	—
Control#71 (Harmonic Content)	OK	OK
Control#72 (Release Time)	OK	—
Control#73 (Attack Time)	OK	—
Control#74 (Brightness)	OK	OK
Control#84 (Portamento Control)	—	OK
Control#91 (Reverb Send Level)	OK	OK
Control#93 (Chorus Send Level)	OK	OK
Control#94 (Variation Send Level)	OK	OK
Control#98 (NRPN LSB)	OK	—
Control#99 (NRPN MSB)	OK	—
Control#100 (RPN LSB)	OK	—
Control#101 (RPN MSB)	OK	—

RPN & NRPN

Event	Initial Setup	Source Pattern
RPN (Pitch Bend Sensitivity)	OK	—
RPN (Fine Tuning)	OK	—
RPN (Null)	OK	—
NRPN (Vibrato Rate)	OK	—
NRPN (Vibrato Delay)	OK	—
NRPN (EG Decay Time)	OK	—
NRPN (Drum Filter Cutoff Frequency)	OK	—
NRPN (Drum Filter Resonance)	OK	—
NRPN (Drum EG Attack Time)	OK	—
NRPN (Drum EG Decay Time)	OK	—
NRPN (Drum Instrument Pitch Coarse)	OK	—
NRPN (Drum Instrument Pitch Fine)	OK	—
NRPN (Drum Instrument Level)	OK	—
NRPN (Drum Instrument Pan)	OK	—
NRPN (Drum Instrument Reverb Send Level)	OK	—
NRPN (Drum Instrument Chorus Send Level)	OK	—
NRPN (Drum Instrument Variation Send Level)	OK	—

System Exclusive

Event	Initial Setup	Source Pattern
Sys/Ex GM on	OK	—
Sys/Ex XG on	OK	—
Sys Ex XG Parameter Change (Effect1)	OK	—
Sys Ex XG Parameter Change (Multi Part)	—	—
DRY LEVEL	OK	OK
Sys Ex XG Parameter Change (Drum Setup)	—	—
PITCH COARSE	OK	—
PITCH FINE	OK	—
LEVEL	OK	—
PAN	OK	—
REVERB SEND	OK	—
CHORUS SEND	OK	—
VARIATION SEND	OK	—
FILTER CUTOFF FREQUENCY	OK	—
FILTER RESONANCE	OK	—
EG ATTACK	OK	—
EG DECAY1	OK	—
EG DECAY2	OK	—

Step Recording (Full Edit)

The Step Recording features lets you record notes with absolutely precise timing. The procedure is essentially the same as that for Song Recording, with the exception of the points listed below:

- Recording resolution for the Style Creator is 96 ppq (parts per quarter-note); for Song Recording it is 384 ppq.
- In Song Recording, the End Mark position can be changed freely; in the Style Creator, it cannot be changed. This is because the length of the style is automatically fixed, depending on the selected section. For example, if you create a style based on a section of four measures length, the End Mark position is automatically set to the end of the fourth measure, and cannot be changed in the Step Recording display.
- Tracks can be changed in Song Recording; however, they cannot be changed in the Style Creator.



Select this to call up the Step Recording display.

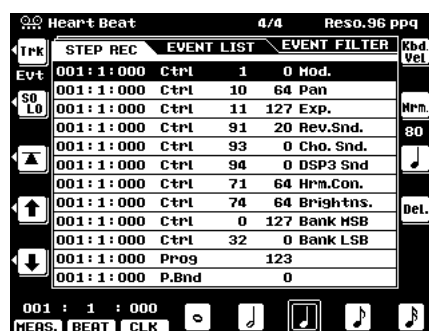

Multi Pad Creator

The 9000Pro has 58 recordable banks that you can use to store your own Multi Pad phrases. These original Multi Pads can be played and used in the same way as the presets. Multi Pad data can also be saved to and loaded from disk.

Basic Procedure

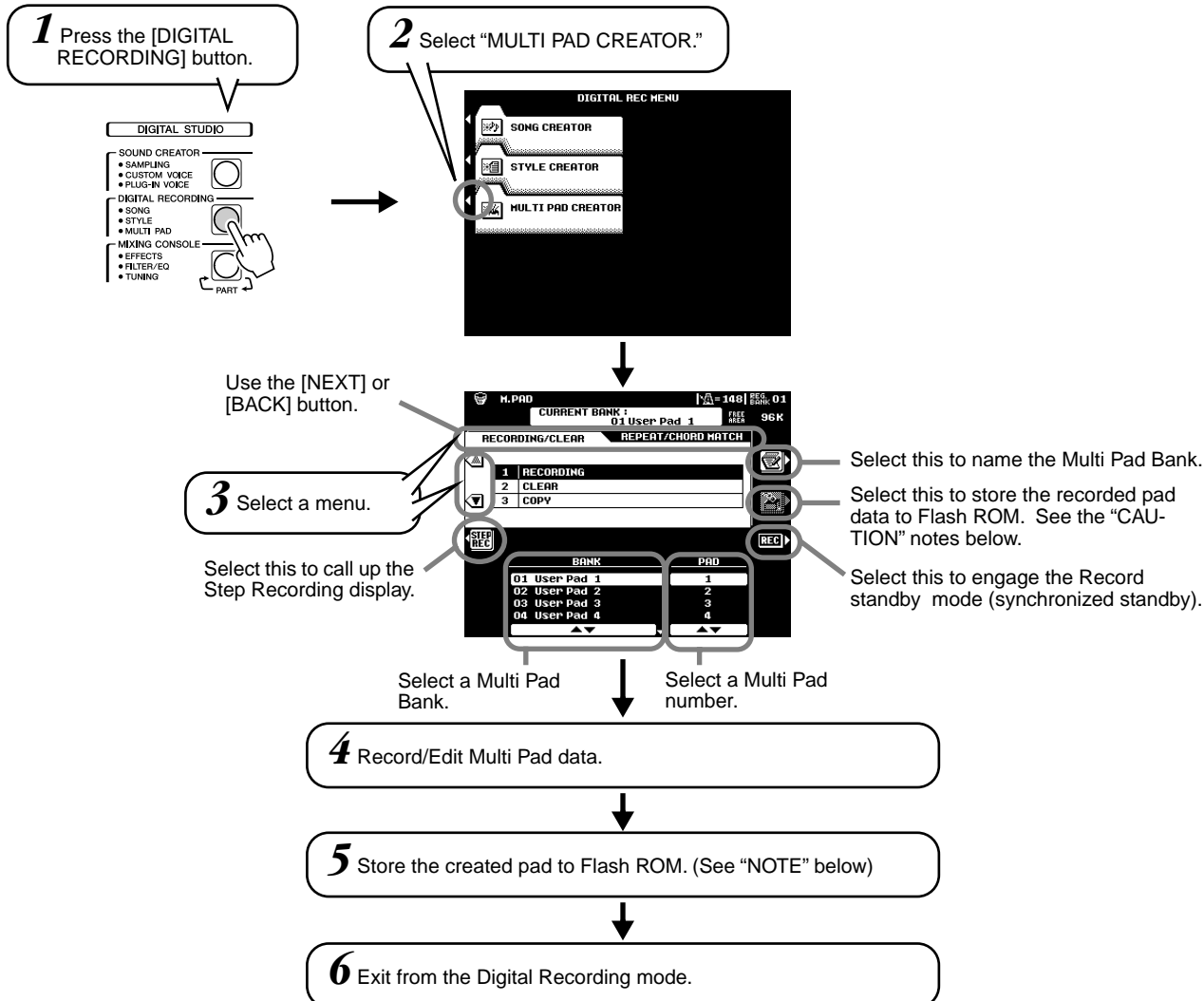

The operations for each function corresponding to step #4 are covered in the following explanations.

NOTE

Since newly created Multi Pad data is stored to Flash ROM, any pre-programmed data in the selected Multi Pad location will be erased and replaced by your new settings. This includes all of the factory programmed Multi Pad banks. If you've deleted the factory-set data, you can use the Restore function (page 154) to load a copy of it from the included disks (page 6).

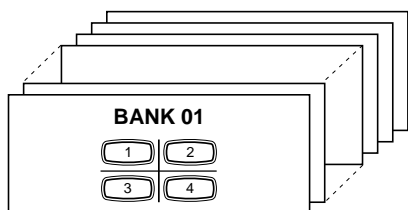

Multi Pad banks
60 banks in Flash ROM
58 banks can be replaced by the new created pad data.

For details about Flash ROM, refer to "Memory Structure" on page 54.

CAUTION

The recorded data of the Multi Pads is stored together in a group of 58 banks in the Flash ROM. For this reason, you should be careful when making edits and storing your edits, since all 58 banks will be overwritten with the new data.

NOTE

Multi Pad banks #59 and #60 contain specially programmed presets for sending MIDI control messages (page 77) and changing the Scale Tuning settings (page 158), respectively. You cannot store your custom Multi Pad data to these banks.

Multi Pad Recording

The explanations here apply to step #4 of the Basic Procedure on page 141.

● Start recording.

Recording begins automatically as soon as you play on the keyboard.

If Chord Match is set to on for the Multi Pad to be recorded, you should record using the notes of the C major seventh scale (C, D, E, G, A and B).

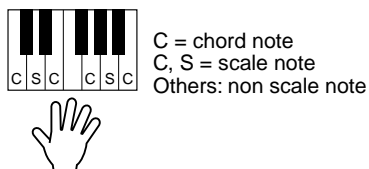

NOTE

- Other notes besides those of the C major seventh scale can be recorded; however, this may result in the recorded phrase not matching the chord when being played back.
- The rhythm part of the currently selected style is used as a rhythmic guide (in place of a metronome), playing back during recording. However, it is not recorded to the Multi Pad.

● Stop recording.

Press the [STOP] LCD button or the panel MULTI PAD [STOP] button to stop recording when you've finished playing the phrase.

Clear

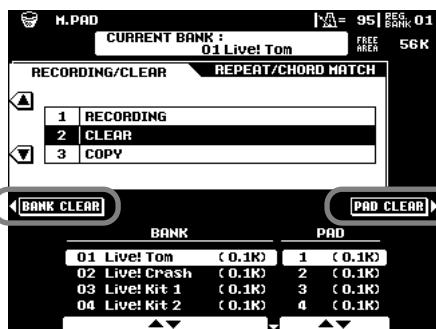

Clears all four pads in the currently selected bank.

Clears only the currently selected pad.

Copy

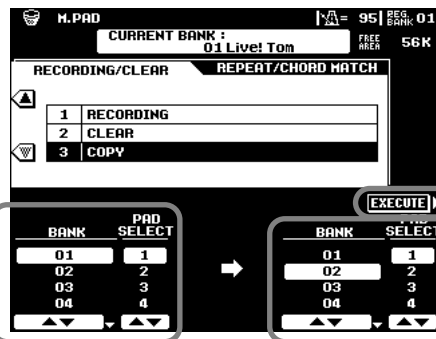

Select the source pad.

Execute the Copy operation.

Select the destination pad. Banks #59 and #60 cannot be selected.

Turning Chord Match and Repeat On/Off

Use the same operation as on page 77.

Step Recording

The Step Recording features lets you record notes with absolutely precise timing. The procedure is essentially the same as that for Song Recording, with the exception of the points listed below:

- Recording resolution for the Multi Pad Creator is 96 ppq (parts per quarter-note); for Song Recording it is 384 ppq.
- Just as with Song Recording, the End Mark position can be changed freely in the Multi Pad Creator. This allows you to finely adjust the phrase length for the Pad. This would be convenient, for example, in synchronizing repeat playback of a Pad (set to Repeat On) with the keyboard and auto accompaniment playback.
- Since the Multi Pads have only one track, the track cannot be changed.

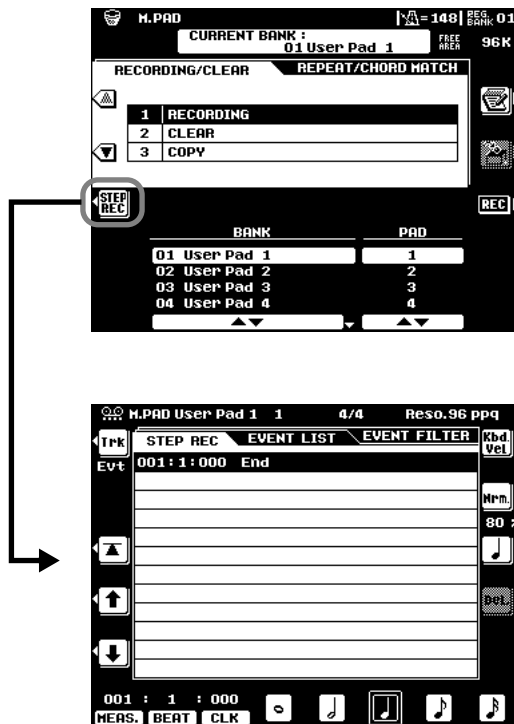

Mixing Console

A full-screen mixing console which provides access to a wide range of controls for each main and accompaniment part can be selected by pressing the [MIXING CONSOLE] button.

A simpler mixing console is available via the [MAIN MIXER] and the [PART ON/OFF] buttons described in “Quick Guide” on pages 24 and 31.

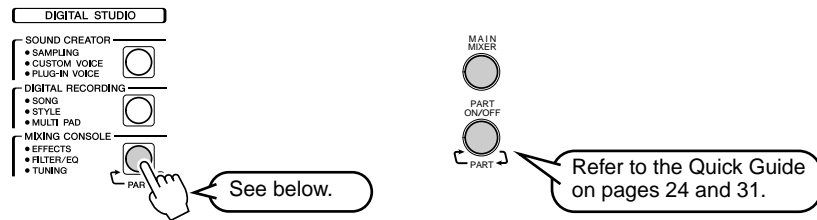

Basic Procedure

1 Press the [MIXING CONSOLE] button several times until the desired parts are displayed.

Pressing the [MIXING CONSOLE] button alternates among the displays as listed below.

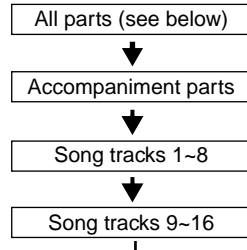

2 Adjust the desired parameter.

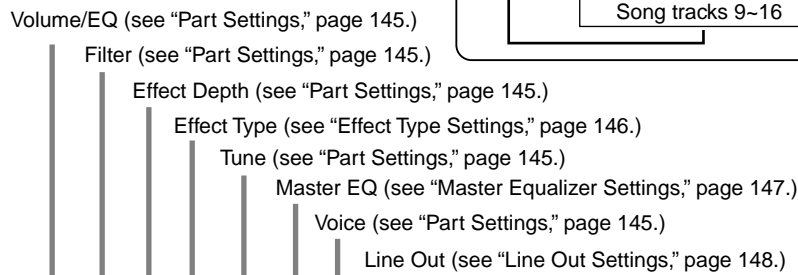

Select the desired menu.

Select the desired menu.

Select the desired parameter.

Select the desired parameter.

Adjust the parameter for each part.

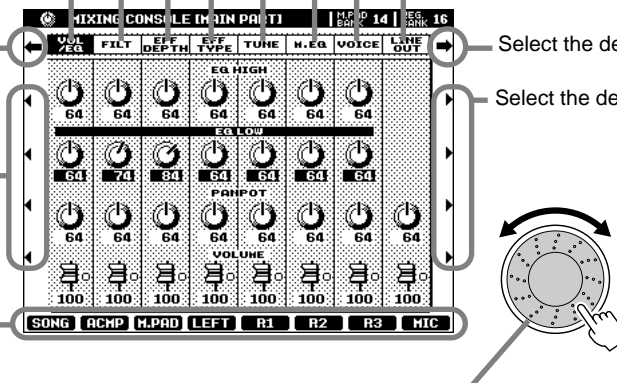

You can use the data dial to adjust the parameter. First, select the desired part by pressing the any of the [1]–[8] buttons and then rotate the data dial to adjust the parameter.

NOTE

- You can also select the desired menu by pressing the [NEXT] or [BACK] button.
- You can change the value of all parts simultaneously. To do this, press any of the LCD [1]–[8] buttons or rotate the data dial while holding the corresponding LCD button ([A]–[J]).

The operations for each parameter corresponding to step #2 are covered in the following explanations.

Part Settings

In addition to the keyboard-played voices, the 9000Pro features many different instrumental “parts,” including those contained in the auto accompaniment, song playback, and vocal harmony. See the next page for details.

		Volume/EQ				Filter		Effect Depth								Tune				VOICE	
		VOLUME	PAN-POT	EQ LOW ***	EQ HIGH ***	BRIGHTNESS	HARMONIC CONTENT	REVERB (1)	CHORUS (2)	DSP (3)	DSP (4)	DSP (5)	DSP (6)	DSP (7)	DSP (8)	TRANSPPOSE *	TUNING	OCTAVE **	PITCH BEND RANGE		PORTAMENTO TIME
Master	Overall	-	-	-	-	-	-	-	-	-	-	-	-	-	-	0	-	-	-	-	-
Keyboard	All Voices	-	-	-	-	-	-	-	-	-	-	-	-	-	-	0	-	-	-	-	-
	VOICE R1	0	0	0	0	0	0	0	0	-	0	-	-	-	-	0	0	0	0	0	-
	VOICE R2	0	0	0	0	0	0	0	0	-	-	0	-	-	-	-	0	0	0	0	-
	VOICE R3	0	0	0	0	0	0	0	0	-	-	-	0	-	-	-	0	0	0	0	-
	VOICE L	0	0	0	0	0	0	0	0	-	-	-	-	0	-	-	0	0	0	0	-
Auto Accompaniment (Style)	All Tracks	0	0	0	0	-	-	0	0	0	-	-	-	-	-	-	-	-	-	-	-
	RHYTHM 1	0	0	0	0	0	0	0	0	0	-	-	-	-	-	-	-	-	-	-	0
	RHYTHM 2	0	0	0	0	0	0	0	0	0	-	-	-	-	-	-	-	-	-	-	0
	BASS	0	0	0	0	0	0	0	0	0	-	-	-	-	-	-	-	-	-	-	0
	CHORD 1	0	0	0	0	0	0	0	0	0	-	-	-	-	-	-	-	-	-	-	0
	CHORD 2	0	0	0	0	0	0	0	0	0	-	-	-	-	-	-	-	-	-	-	0
	PAD	0	0	0	0	0	0	0	0	0	-	-	-	-	-	-	-	-	-	-	0
	PHRASE 1	0	0	0	0	0	0	0	0	0	-	-	-	-	-	-	-	-	-	-	0
	PHRASE 2	0	0	0	0	0	0	0	0	0	-	-	-	-	-	-	-	-	-	-	0
Multi Pad	Multi Pad 1-4	0	0	0	0	-	-	0	0	-	-	-	-	-	-	-	-	-	-	-	-
Song	All Tracks	0	0	0	0	-	-	0	0	0	-	-	-	-	-	0	-	-	-	-	-
	TRACK 1	0	0	0	0	0	0	0	0	0	-	-	-	-	-	-	-	-	-	-	0
	TRACK 2	0	0	0	0	0	0	0	0	0	-	-	-	-	-	-	-	-	-	-	0
	•	•	•	•	•	•	•	•	•	•	•	•	•	•	•	•	•	•	•	•	•
	TRACK 16	0	0	0	0	0	0	0	0	0	-	-	-	-	-	-	-	-	-	-	0
Microphone Sound	MIC	0	0	-	-	-	-	0	0	-	-	-	-	-	0	-	-	-	-	-	-

O : available
 * Same as the [TRANSPPOSE] button (pages 61 and 162)
 ** Same as the [UPPER OCTAVE] button (page 18)
 *** Cannot be applied to the part using the Plug-in voice from the PLG150-PF. If you wish to adjust them from the PLG150-PF, use the Native Part Parameter settings display (Frequency/Gain) in the Plug-in Custom Voice Creator function.

● Volume/EQ

- Volume This lets you change the volume of each part and adjust the relative balance among all the parts.
- Panpot..... Positions the sound of the specified voice or track from left to right in the stereo sound field.
- Equalizer The EQ High and EQ Low controls function in the same way as the treble and bass controls on a sound system, boosting or cutting the high or low frequency ranges by the specified amount.

● Filter

- Brightness..... This increases or decreases the brightness of the sound.
- Harmonic Content.. This increases or decreases the harmonic content, giving the sound more or less “punch.”

● Effect Depth

This parameter sets the effect depth for the corresponding part. See the next page for details about Effects.

● Tune

- Transpose..... Allows the pitch to be transposed up or down in semitone increments (pages 61 and 162).
- Tuning..... Sets the pitch for the corresponding part.
- Octave..... Shifts the pitch of the specified part up or down by one or two octaves. The value of this parameter is added to the value set via the [UPPER OCTAVE] button (page 18).
- Pitch Bend Range.. Sets the range of the PITCH BEND wheel for the corresponding part. The range is from “0” to “12” with each step corresponding to one semitone.
- Portamento Time.... Sets the portamento time for the corresponding part only when the part is set to “MONO” (page 60). The higher the value the longer the portamento time. The portamento effect (a smooth slide between notes) is produced when the notes are played legato: i.e., a note is held while the next note is played.

● Voice

This lets you change the voice for each part.

NOTE

- Make the desired Right 1 voice, Effect Type and Depth, and EQ settings from the Mixing Console, then call up the Custom Voice display to store the settings. The Mixing Console parameters can be stored together with the Custom Voice parameters.

NOTE

- Certain voices may produce excessive noise, depending on the Harmonic Content and/or Brightness settings of the Mixing Console Filter.

HINT

- As indicated in the chart above, in addition to the Master Transpose setting, there are two other transpose controls: Keyboard Transpose and Song Transpose. These can be used to match both the song and your keyboard performance to a certain key. For example, let's say you wish to both play and sing along with a certain recorded song. The song data is in F, but you feel most comfortable singing in D, and you are accustomed to playing the keyboard part in C. To match up the keys, set the Master Transpose to “0,” the Keyboard Transpose to “2,” and the Song Transpose to “-3.” This brings the keyboard part up and the song data down to your comfortable singing key.

Effect Type Settings

With the digital effects built into the 9000Pro you can add ambiance and depth to your music in a variety of ways—such as adding reverb that makes you sound like you are playing in a concert hall for a full, rich sound.

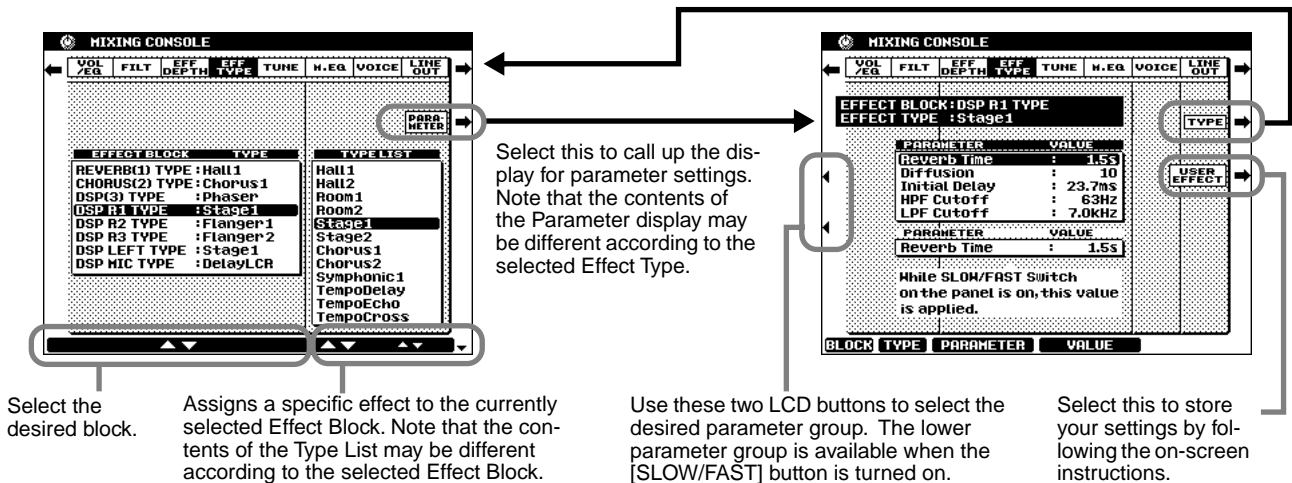

Effect Block

The 9000Pro has 9 independent digital signal processing (DSP) blocks for effects, plus the Vocal Harmony processor. Each DSP block applies to a specific part or portion of the 9000Pro sound, as listed below. The DSP block numbers appear in several locations on the 9000Pro panel and in some of the display screen for easy reference: e.g., REVERB (1), CHORUS (2), DSP (3), DSP (4), etc.

	Parts to be applied	Description
Reverb (1)	Overall	Creates a reverb effect that makes you sound like you are playing in places like a concert hall, or live in a club.
Chorus (2)	Overall	Adds a chorus effect that makes your playing sound as though multiple parts were being played together at the same time.
DSP (3)	Auto Accompaniment/Song	In addition to the Reverb and Chorus types, the 9000Pro has special DSP effects, that include additional effects usually used for a specific part, such as distortion and tremolo.
DSP (4)	VOICE RIGHT1	This block (which can be turned on or off by a panel button) is applied to the RIGHT1 voice.
DSP (5)	VOICE RIGHT2	This block (which can be turned on or off by a panel button) is applied to the RIGHT2 voice.
DSP (6)	VOICE RIGHT3	This block (which can be turned on or off by a panel button) is applied to the RIGHT3 voice.
DSP (7)	VOICE LEFT	This block (which can be turned on or off by a panel button) is applied to the LEFT voice.
DSP (8)	Microphone Sound	This block (which can be turned on or off by a panel button) is applied to the microphone sound.
Vocal Harmony (9)	Vocal Harmony	This block (which can be turned on or off by a panel button) is used for the Vocal Harmony effect. See page 81.

NOTE

- You may find that, when changing a drum sound of an auto accompaniment style and then restoring the original drum sound, the actual sound (especially the effect processing — Reverb, Chorus, and DSP 3) sounds different than the original. To restore the original drum sound and its effect processing, select a different style, then select the original style once again.
- Some effect types (e.g., TempoDelay, VDsth+TDly, etc.) are synchronized with the current tempo. When any of these effect types is selected, noise may result when simultaneously playing the keyboard and pressing the [SLOW/FAST] button or changing the tempo. To avoid this, first stop playing the keyboard, then press [SLOW/FAST] or change the tempo.
- Editing some of the effect parameters may produce a small amount of noise.

About the Effect Connections – System and Insertion

All the effect blocks are connected or routed in one of two ways: System or Insertion. System applies the selected effect to all parts, while Insertion applies the selected effect to one specific part. Reverb (1) and Chorus (2) are System effects, and DSP (4) - Vocal Harmony (9) are Insertion effects. The DSP (3) effect, on the other hand, can be configured for either System or Insertion routing. (This is done from the parameters of the individual effect type; see above.)

Master Equalizer Settings

Usually an equalizer is used to correct the sound output from amps or speakers to match the special character of the room. The sound is divided into several frequency bands, allowing you to correct the sound by raising or lowering the level for each band. The equalizer allows you to adjust the tone or timbre of the sound to match the performance space, or to compensate for certain acoustic characteristics in your room. For example, you can cut some of the low range frequencies when playing in large spaces where the sound is too “boomy,” or boost the high frequencies in rooms and close spaces where the sound is relatively “dead” and free of echoes.

The 9000Pro possesses a high grade five-band digital equalizer function. With this function, a final effect—tone control—can be added to the output of your instrument.

An edited PRESET or USER curve can be stored to USER 1.

An edited PRESET or USER curve can be stored to USER 2.

Adjusts the overall gain of all EQ bands simultaneously.

The PRESET and USER curves can be edited as required via the corresponding LCD buttons — EQ1 through EQ5. Each of the 5 bands can be boosted (“+” values) or cut (“-” values) by up to 12 dB.

Whenever an EQ band is edited the corresponding EQ value is highlighted and the number of the edited band appears above the Q and FREQ controls. The Q and FREQ controls can then be used to adjust the Q (bandwidth) and the FREQ (center frequency) of the selected band. The higher the “Q”, the narrower the bandwidth. The available FREQ range is different for each band.

●Effect Signal Flow Chart

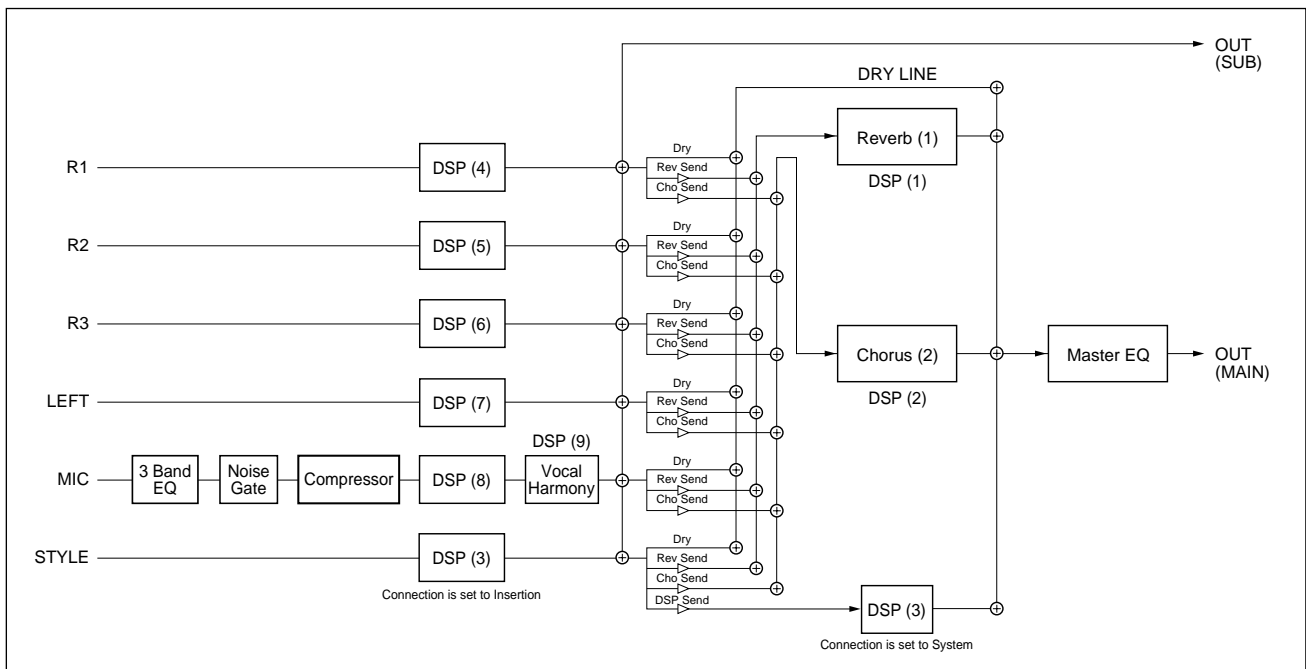

Line Out Settings

This convenient feature allows you to send the output of a selected Part or Parts to the LINE OUT jacks.

For Drum Parts, you can even select specific drum sounds to be output through these jacks.

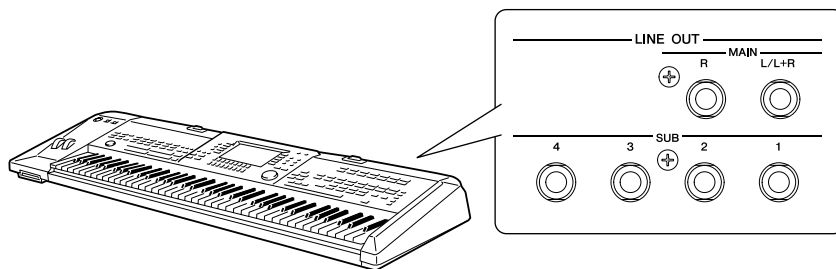

In general, the extensive built-in effects and other Part controls of the 9000Pro provide all you need for processing and mixing complex multi-Part songs. However, there may be times when you want to “sweeten” or process a certain Voice or sound with a favorite outboard effect unit, or record a Part to a separate track of a tape recorder. The Line Out settings are designed just for these kinds of applications.

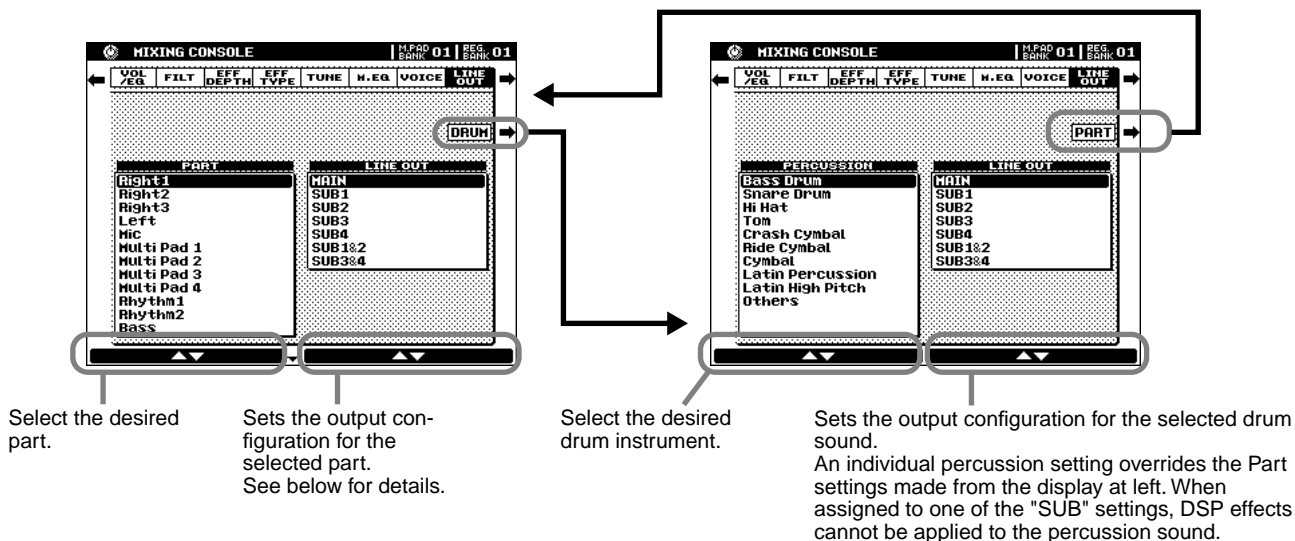

- When set to “MAIN,” the part is output (with effects) through the MAIN LINE OUT jacks. The sound is also output through the PHONES jack, as well as the MAIN jacks.
- When set to one of the “SUB” settings, the Part is output through the SUB LINE OUT jacks. In this case, only Insertion effects (DSP4 - 8 and DSP3 when this is set to “Insertion” from the effect parameter display) can be applied; System effects (DSP1, 2 and DSP3 when this is set to “System” from the effect parameter display) and MASTER EQ cannot be applied to the SUB LINE OUT jacks.
- When set to one of the “SUB” settings, the sound of the Part will not be output through the PHONES jack.
- When set to “SUB1&2,” the Part is output in stereo (1: left, 2: right).
- When set to “SUB3&4,” the Part is output in stereo (3: left, 4: right).
- Settings of “SUB1,” “SUB2,” “SUB3,” and “SUB4” output the Part in mono to the corresponding jack.
- Parts output through the SUB LINE OUT jacks cannot be heard through the PHONES jack.

NOTE

• When using one of the “SUB” Line Out settings, make sure that you’ve connected cables to the appropriate SUB LINE OUT jacks on the rear panel. If cables are only connected to the MAIN jacks, the sound of the Part will be output through the MAIN jacks, even if one of the “SUB” Line Out settings is selected.

Example 1 — Live Performance

In this example, you can send the metronome click to the drummer in your band, and keep everything in sync.

		Line Out Settings
Part Settings	Right1, 2, 3, Left	MAIN
	Mic	SUB1
	Multi Pad 1, 2, 3, 4	MAIN
	Auto Accompaiment (Rhythm1, Rhythm2, Bass, Chord1, Chord2, Pad, Phrase1, Phrase2)	MAIN
	Metronome	SUB2
	Song (Song Tr1 - 16)	MAIN
Drum Settings	All instruments	SUB3&4

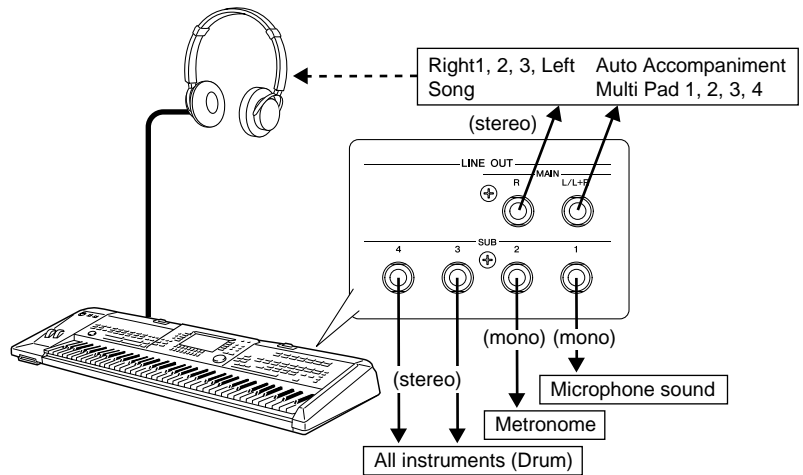

Example 2 — “Surround Sound” System

In this example, send each output to a different speaker for a rich, surround effect.

		Line Out Settings
Part Settings	Right1, 2, 3, Left	MAIN
	Mic	MAIN
	Multi Pad 1, 2, 3, 4	MAIN
	Auto Accompaiment (Rhythm1, Rhythm2, Bass, Chord1, Chord2, Pad, Phrase1, Phrase2)	SUB1&2
	Metronome	MAIN
	Song (Song Tr1 - 16)	MAIN
Drum Settings	All instruments	SUB3&4

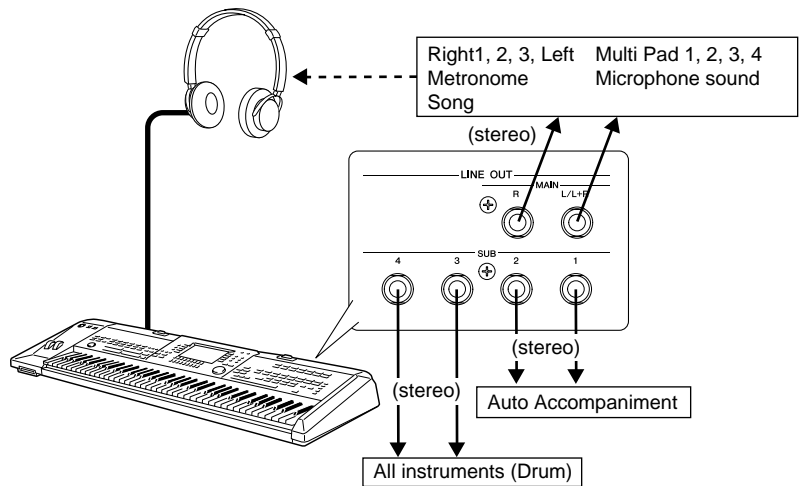

Example 3 — Recording

In this system, connect a multi-track recorder and record each part separately, just as is done in professional recording studios.

		Line Out Settings
Part Settings	Right1, 2, 3, Left	MAIN
	Mic	MAIN
	Multi Pad 1, 2, 3, 4	MAIN
	Auto Accompaiment (Rhythm1, Rhythm2, Bass, Chord1, Chord2, Pad, Phrase1, Phrase2)	MAIN
	Metronome	MAIN
	Song (Song Tr1 - 16)	MAIN
	Drum Settings	Bass Drum
	Snare Drum	SUB2
	Other instruments	SUB3&4

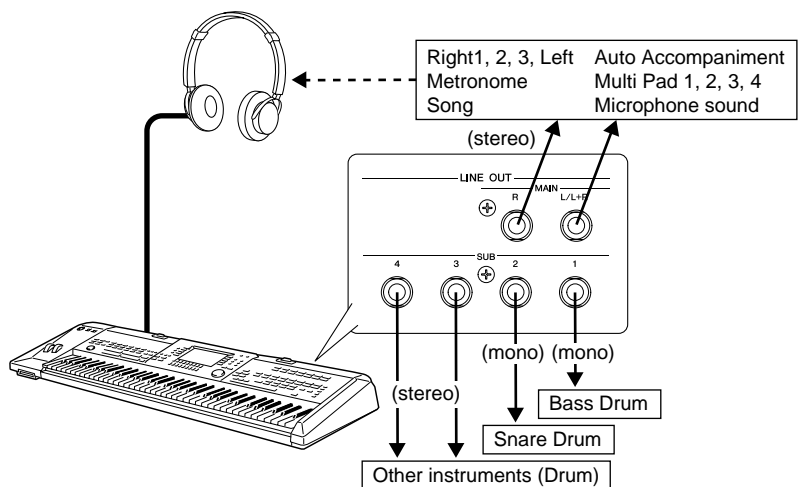

Disk/SCSI Operations

The 9000Pro [DISK/SCSI] button accesses a range of functions that are used for storage and retrieval of floppy disk data. The 9000Pro can also be fitted with an optional internal hard disk or an optional connected SCSI device for massive on-line storage capacity.

Storage Devices Compatible with the 9000Pro

• Floppy disk

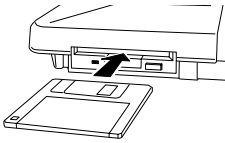

IMPORTANT
 • Make sure to read the section "Using the Floppy Disk Drive (FDD) and Floppy Disks" on page 5.

• SCSI device (optional connected)



Devices in this category include external hard disk drives, removable cartridges, etc. See page 13 for details on SCSI device connection.

• Internal hard disk drive (optional installed)

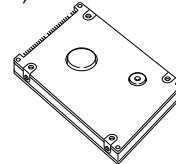

See page 184 for details on hard disk installation.

If an optional SCSI device is connected or the optional internal hard disk is installed, the corresponding device names appear in the LCD of the disk related function.

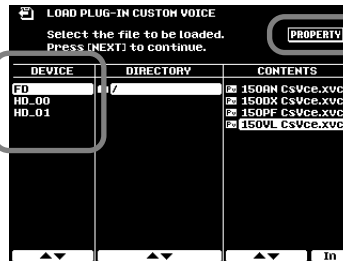

Select this to display the property of the selected file.

Basic Procedure

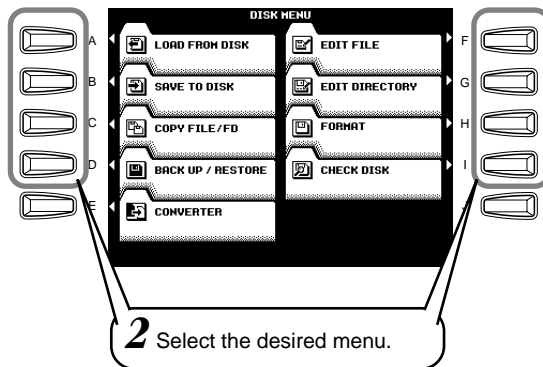
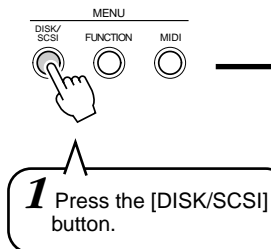

3 Execute the desired function.

The operations for each function corresponding to step #3 are covered in the following explanations.

The Disk mode has the following display pages:

• LOAD FROM DISK	Loading data from a disk to Flash ROM.....	152
• SAVE TO DISK	Saving data from Flash ROM to a disk.....	153
• COPY FILE/FD	Copying files & copying floppy disks.....	154
• BACK UP/RESTORE	Backing up/restoring the data in Flash ROM.....	154
• CONVERTER	Converting PSR-8000 format files to 9000Pro format files.....	155
• EDIT FILE	Renaming/deleting disk files.....	155
• EDIT DIRECTORY	Renaming/deleting/creating directories.....	156
• FORMAT	Formatting a disk.....	156
• CHECK DISK	Checking a disk.....	157

Before going on to the explanations of the above functions, make sure to read through the instructions on Basic Operation and Selecting Directories/Files below. The following explanations apply to the Plug-in Manager function (page 66), Style Manager function (page 74), Disk Song file selection (page 78) and other disk-related functions, as well as the Disk/SCSI functions described in this chapter.

Basic Operation — Directory/File Selection

NOTE

In the file selection display, a maximum 250 file or directory names can be displayed. If the number of files or directories exceeds 250, the 251st and beyond (according to alphabetical order) are not shown.

Selecting files

The 9000Pro provides three ways to select files: SINGLE, MULTI, and ALL.

- When set to SINGLE, you can select only one file.
- When set to ALL, you can select all files.
- When set to MULTI, you can select files listed consecutively.

For more information about MULTI, see the example (Style Manager) below.

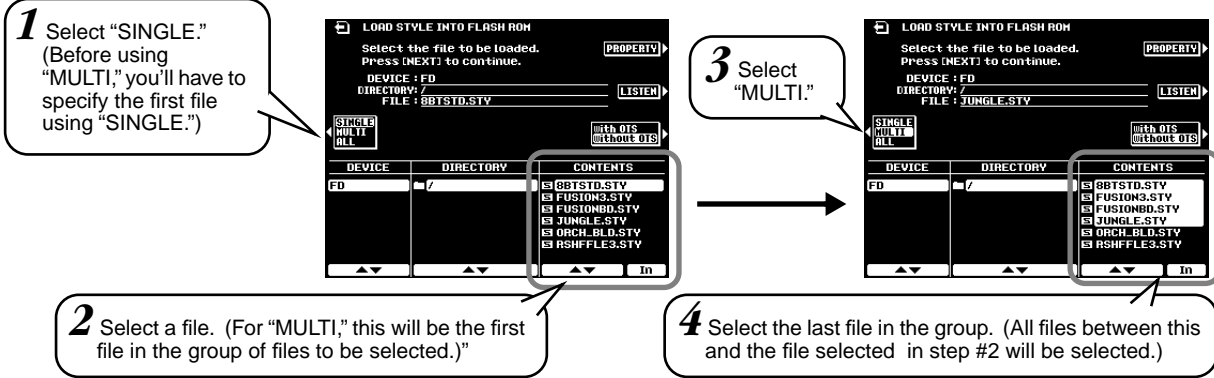

To cancel "Multi" file selection, select "SINGLE" by pressing the [C] button twice.

CAUTION The following explanation applies to the Load operation of the Plug-in Manager and the Style Manager function.

- When loading multiple files from disk to Flash ROM, only the selected files will be loaded to the destination location in the Flash ROM (see pages 78 and 87). Keep in mind that the files are loaded to consecutive locations starting from the specified destination. Make sure that the consecutive locations contain no important data, otherwise you may inadvertently overwrite files you wish to keep.

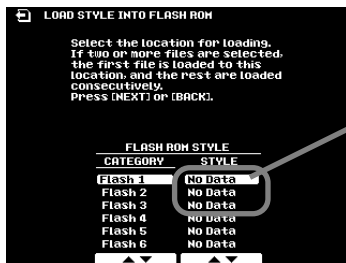

If you select this location as the destination in Flash ROM with selecting three files in disk, for example, the three locations in Flash ROM are replaced starting from this location.

Selecting Directories/Files

Directories are like file "folders" that are used to organize the file data. The instructions here show you how to navigate through directories and select the desired directories/files.

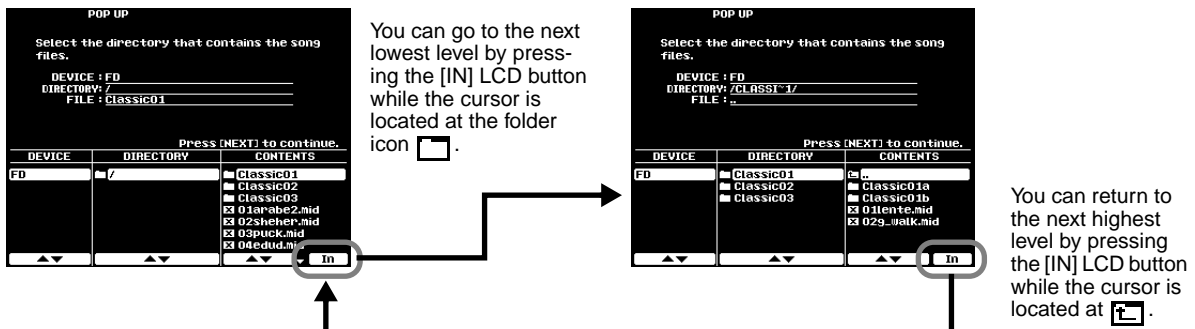

Loading Data from a Disk to Flash ROM

This operation lets you load the specified file from a floppy disk, an optional hard disk, or an optional SCSI device to Flash ROM.

The explanations here apply to step #3 of the Basic Procedure on page 150.

● **Select a source file in the disk.**

If an optional hard disk has been installed or an optional SCSI device has been connected, the appropriate device must be selected here.

PROPERTY

DEVICE : FD
 DIRECTORY : /
 FILE : UF_001.usp

FREE AREA 1403 K

DEVICE DIRECTORY CONTENTS
 FD / UF_001.usp

PRESS (NEXT) TO CONTINUE.

PAGE CONTROL
 BACK NEXT

Select this to display the property of the selected file.

For details on directory file selection, see page 151.

CAUTION

- When data is loaded from a floppy disk to the 9000Pro, the data already in the memory of the instrument will be replaced by the data on the disk. Save important data to a disk file before doing the Load operation.

● **Select a Load method.**

LOAD FROM DISK FREE AREA 1351 K

GROUP

INDIVIDUAL

DEVICE : FD
 DIRECTORY : /
 FILE : UF_001.USR

Press (NEXT) to continue.

PAGE CONTROL
 BACK NEXT

NOTE

- Loading style data can be executed via the Style Manager function (page 74).

● **Select the destination.**

LOAD FROM DISK FREE AREA 1351 K

INDIVIDUAL USER DATA LOAD

Load BANK 01 in the file UF_001 to the destination BANK 01.

Press (NEXT) to continue.

DATA CONTENT DESTINATION

BANK 01 BANK 01

BANK 02 BANK 02

BANK 03 BANK 03

BANK 04 BANK 04

BANK 05 BANK 05

BANK 06 BANK 06

BANK 07 BANK 07

LOAD FROM DISK FREE AREA 1351 K

USER DATA LOAD

SETUP EFFECT DATA REGIST. MULTI CUSTOM ORGAN
 PAD VOICE FLUTES

ON ON ON ON ON ON
 OFF OFF OFF OFF OFF OFF

Press (NEXT) to continue.

Select the source data in the disk.

Select the destination.

Set the data type to ON or OFF. Data types set to ON will be loaded. Flash ROM data for which the data type has been set to OFF will be retained.

PAGE CONTROL
 BACK NEXT

SETUP	All setup data — see list on page 214.
EFFECT DATA	All User effect data — page 146.
REGISTRATION	All Registration Memory data — page 214.
MULTI PAD	All Multi Pad data — page 141.
CUSTOM VOICE	All Custom Voice data including wave data saved using the Wave save option — page 92.
ORGAN FLUTES	All Organ Flutes settings — page 62.

● **Execute the Load operation by following the on-screen instructions.**

Saving Data from Flash ROM to a Disk

The data types described below can be saved to a floppy disk, an optional hard disk, or an optional SCSI device.

The explanations here apply to step #3 of the Basic Procedure on page 150.

● **Select the data type to be saved.**

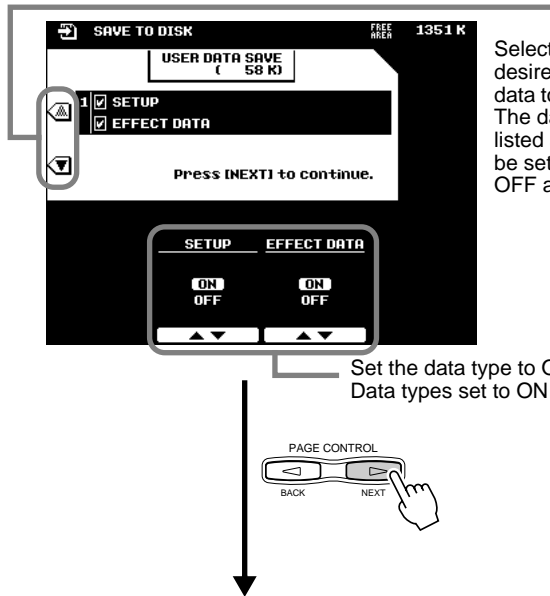

Select the desired group of data to be saved. The data types listed at right can be set to ON or OFF as desired.

Set the data type to ON or OFF. Data types set to ON are saved.

SETUP	All setup data — see list on page 214.
EFFECT DATA	All User effect data — page 146.
REGISTRATION BANK	All Registration Memory data — page 214. You can set the individual banks to ON or OFF.
MULTI PAD	All Multi Pad data — page 141. You can set the individual banks to ON or OFF.
CUSTOM VOICE	All Custom Voice data — page 92. You can set the individual numbers to ON or OFF. If necessary, use the Wave save option.
ORGAN FLUTES	All Organ Flutes voice settings — page 62. You can set the individual numbers to ON or OFF.

● **Select the destination file in the disk.**

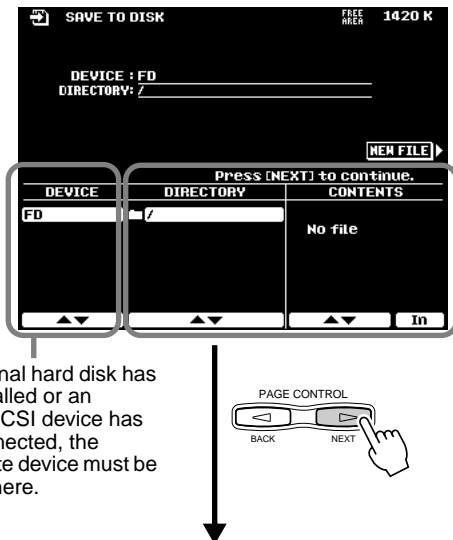

For details on directory file selection, see page 151.

If an optional hard disk has been installed or an optional SCSI device has been connected, the appropriate device must be selected here.

CAUTION

• When overwriting an existing file, all data is saved. This means that previous data corresponding to unchecked (OFF) items will be overwritten with "empty" data.

NOTE

• Saving style data can be executed via the Style Manager function (page 74).

● **Execute the Save operation by following the on-screen instructions.**

Copying Files & Copying Floppy Disks

The Copy File function allows you to copy files to a different directory on the same disk, or to another disk. The Copy Floppy Disk (COPY FD) function allows you to make complete copies of floppy disks — a perfect way to make backup copies of your important data.

The explanations here apply to step #3 of the Basic Procedure on page 150.

● Select the desired menu.

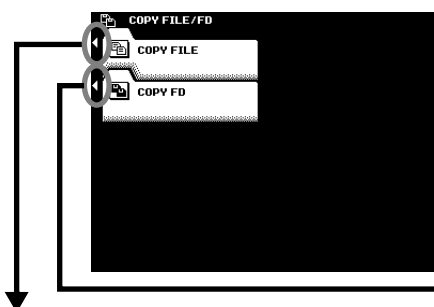

Execute the COPY FD operation by following the on-screen instructions.

NOTE

- The COPY FD function cannot be used to copy hard disk data.
- Copies can only be made to the same type of floppy disk as the source disk (i.e. 2HD to 2HD or 2DD to 2DD).
- Some types of pre-recorded music software disks are copy protected.

● Select the source files.

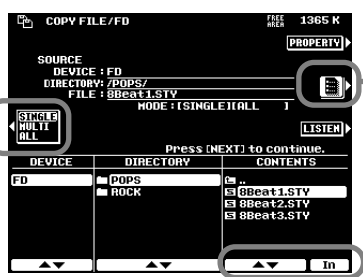

Press this button to change the type of files (as indicated by their extension) displayed in the FILE column.

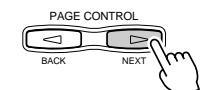

See page 151.

Use these buttons. For details about selecting files, see page 151.

● Select the destination device and directory.

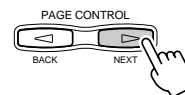
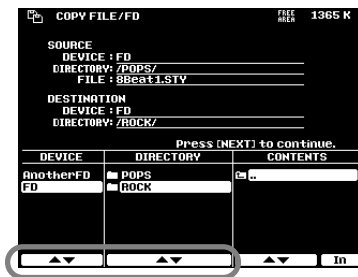

Execute the Copy operation by following the on-screen instructions.

Use these buttons. "Another FD" is indicated at the bottom of the Device column. Select "Another FD" if you wish to copy to another floppy disk.

Backing Up/Restoring the Data in Flash ROM

Any data that was pre-recorded in Flash ROM will be erased and replaced by the new settings. This means that preset setups (factory settings) will also be erased. It is therefore a good idea to save them to disk via the Backup function before recording or creating your own original data so that you can keep them indefinitely.

The explanations here apply to step #3 of the Basic Procedure on page 150.

● Select the desired menu.

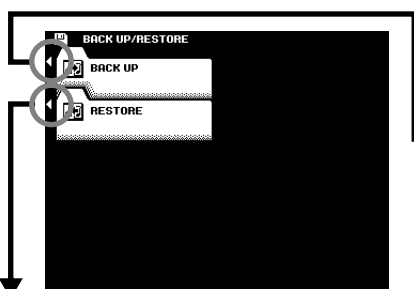

Select a file to be restored to Flash ROM and execute the Restore operation by following the on-screen instructions.

● Select the data type to be backed up.

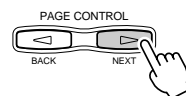
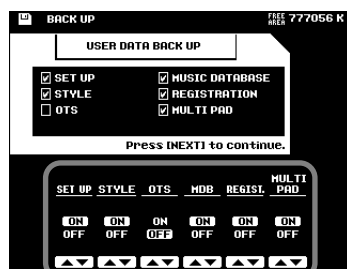

Execute the Backup operation by following the on-screen instructions.

Set the data type to ON or OFF. Data types set to ON are backed up.

Converting files

This function is useful for when you want to use PSR-8000 data contained on a floppy disk with the 9000Pro, or for when you wish to install a hard disk previously installed to a PSR-8000, to the 9000Pro.
 The following data created via the PSR-8000 is available:

- Custom Style
- Song
- Chord Step
- Waveform

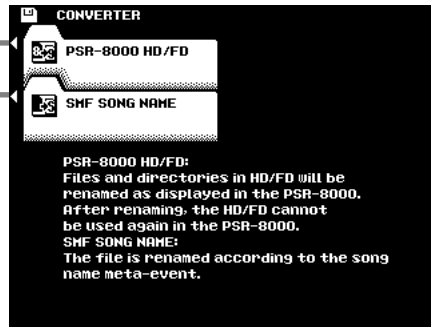

CAUTION

- Please note that the HD/FD cannot be used again in the PSR-8000 after using PSR-8000 HD/FD function.

This function changes the sequence/track name of the Meta Event of the Standard MIDI file to the song name of the 9000Pro. Save the SMF files before using this function as required.

Renaming/deleting Disk Files

These functions allow you to assign a name to the file, and to delete any unnecessary files.

The explanations here apply to step #3 of the Basic Procedure on page 150.

- Select the desired menu.

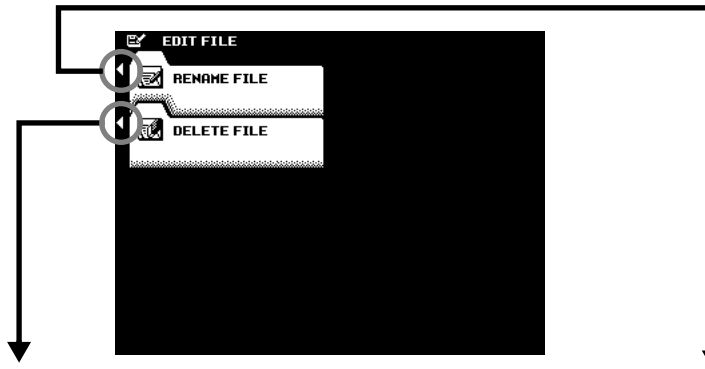

- Select the file to be deleted.

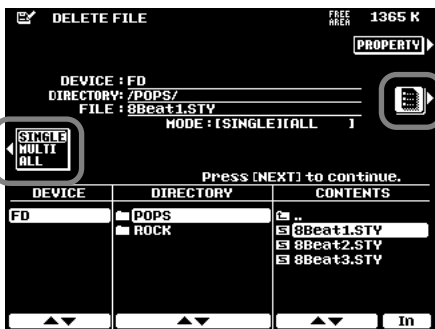

Press this button to change the type of files (as indicated by their extension) displayed in the FILE column.

See page 151.

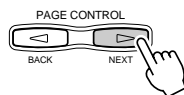

Execute the Delete operation by following the on-screen instructions.

- Select the file to be named.

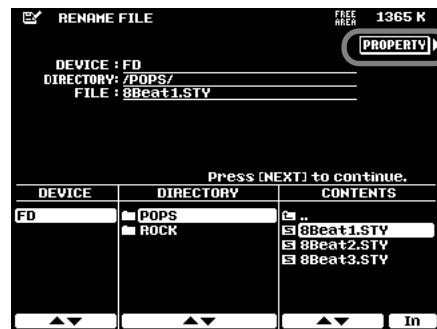

Select this to display the properties of the selected file.

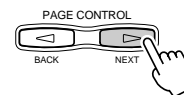

Enter a name for the selected file. Refer to the Basic Operation on page 46.

Renaming/deleting/creating Directories

The explanations here apply to step #3 of the Basic Procedure on page 150.

- Select the desired menu.

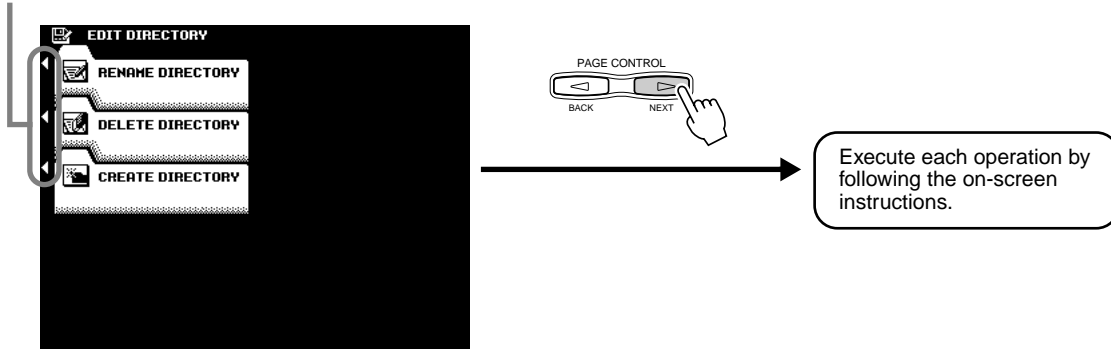

Formatting a Disk

Setting up commercially available blank floppy disks for use with 9000Pro is called formatting. This function is also useful for quickly deleting unnecessary files from an already formatted disk. Be careful when using this operation, since it automatically deletes all data on the disk.

The explanations here apply to step #3 of the Basic Procedure on page 150.

- Select the device to be formatted.

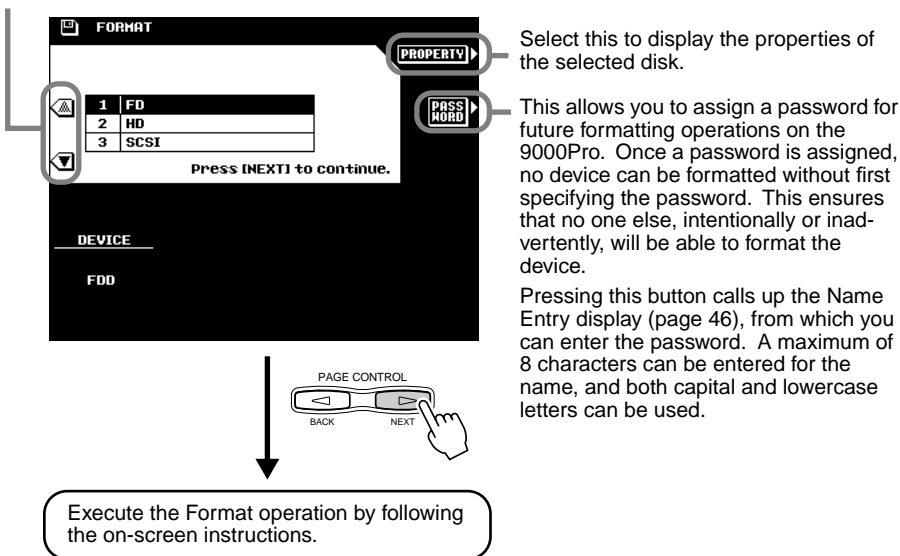

CAUTION

- Formatting a disk completely erases all data on the disk, so be sure that the disk you're formatting does not contain important data!

NOTE

- Hard disk drives of a maximum 8 GB capacity can be formatted; however, the maximum partition size is 2 GB. For example, an 8 GB hard disk drive would have to be formatted into four separate 2 GB partitions.
- Hard disk drives of a capacity greater than 8 GB can be installed; however, the 9000Pro is capable of formatting only up to a maximum 8 GB on the drive.

IMPORTANT

- Make sure to write down your password and keep in a separate, secure location, in case you forget it.

Checking a Disk

This function can be used to check an entire disk for damaged files and recover the files so that they can be properly read. Keep in mind that, depending on the extent of the damage, some files may not be recoverable.

The explanations here apply to step #3 of the Basic Procedure on page 150.

● Select the device to be checked.

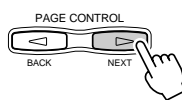
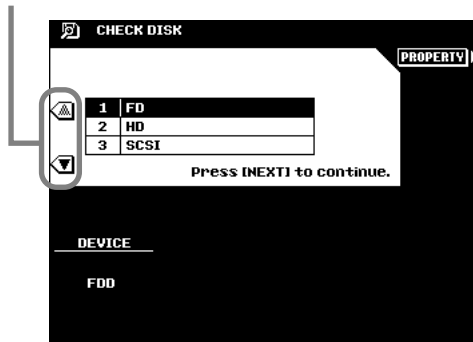

Execute the Check operation by following the on-screen instructions.

The 9000Pro "Functions"

The 9000Pro "Function" mode includes 8 groups of functions that access a number of parameters related to overall 9000Pro operation.

Basic Procedure

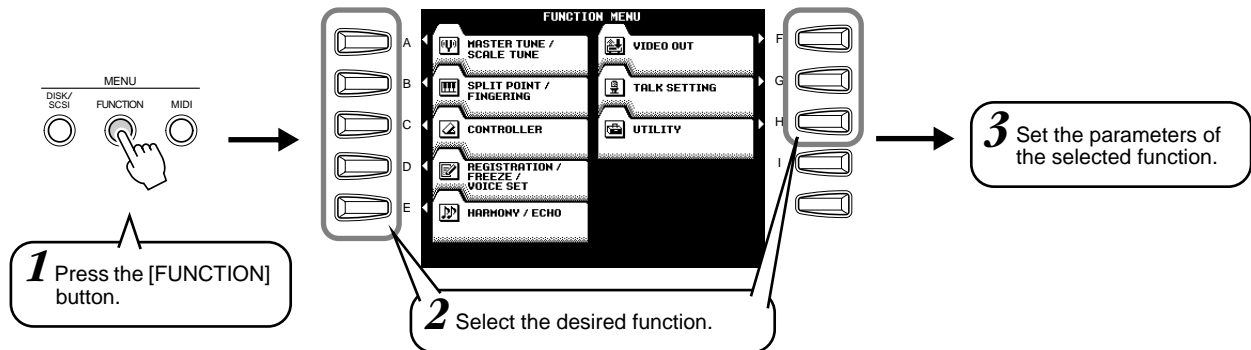

The operations for each function corresponding to step #3 are covered in the following explanations.

The Function mode has the following display pages:

- MASTER TUNE/SCALE TUNE Master Tuning/Scale Tuning 158
- SPLIT POINT/FINGERING Split Point/Fingering settings..... 159
- CONTROLLER Controller assignment (Foot controller/Keyboard/Modulation Wheel function)..... 159
- REGISTRATION/FREEZE/VOICE SET Registration/Freeze Group/Voice Set settings 163
- HARMONY/ECHO Harmony/Echo settings 164
- VIDEO OUT Video monitor settings..... 165
- TALK SETTING Talk setting (Vocal Harmony and the microphone sound settings)..... 165
- UTILITY Utility settings 166

Master Tuning/Scale Tuning

The explanations here apply to step #3 of the Basic Procedure above.

Master Tuning



Tune the overall pitch of the 9000Pro from 414.6 - 466.8 Hz (referenced to A3). A3 = 440 Hz is standard "concert" pitch.

Scale Tuning

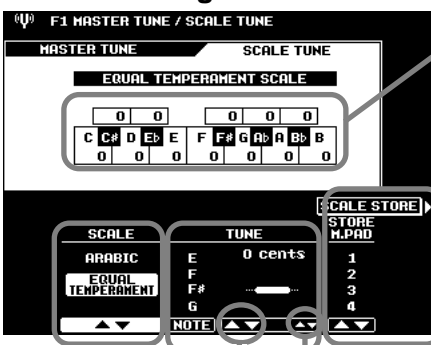

The current tuning of each note is shown in the corresponding key.

This allows you to store four different Scale Tuning settings to Multi Pad bank #60. This convenient feature lets you change Scale Tuning settings while you are playing, simply by pressing the appropriate Multi Pad. Preset (factory set) data is listed in the chart below.

Fine-tune the selected note in 1-cent steps.

Coarse-tune the selected key in 10-cent steps.

When the ARABIC scale is selected, you can select the note and tune it. The tuning range is from "-64" through "0" to "+63". Each increment equals one cent (one "cent" is one hundredth of a semitone).

Select either the normal equal temperament scale or an "arabic" scale in which each note can be tuned over a 127-cent range.

		C	C#	D	D#	E	F	F#	G	G#	A	A#	B
Pad1	RASD Up	0	0	0	0	-50	0	0	0	0	0	0	-50
Pad2	RASD Down	0	0	0	0	-50	0	0	0	0	0	0	0
Pad3	BAYATI	0	0	0	0	-62	0	0	0	0	0	0	0
Pad4	Equal Tem-	0	0	0	0	0	0	0	0	0	0	0	0
	perament												

Split Point/Chord Fingering

The explanations here apply to step #3 of the Basic Procedure on page 158.

You can set the Split Point by pressing the desired key while holding this button.

Split Point is valid when Left and/or Auto Accompaniment is on.
The Fingering Mode determines how chords are recognized in Auto Accompaniment.

The way in which chords are played or indicated with your left hand (in the auto accompaniment section of the keyboard) is referred to as "fingering." For details, refer to page 70.

The point on the keyboard that separates the auto accompaniment section/the left-hand section (voice L) and the right-hand section (voice R1/ R2/R3) of the keyboard is called the "split point." For details, refer to page 57.

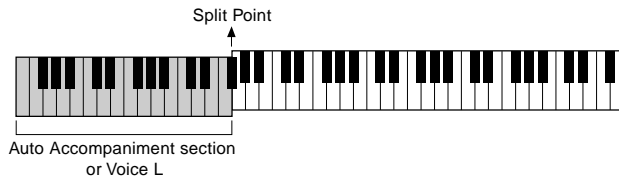

Controller Assignment

The explanations here apply to step #3 of the Basic Procedure on page 158.

Foot Controller

Various functions can be assigned to the foot volume/switch connected to the FOOT PEDAL jacks.

Foot Volume Controller

Determines whether an optional YAMAHA FC7 Foot Controller plugged into the rear-panel FOOT PEDAL VOLUME jack will control master volume, or only the volume of specified parts and voices.

Select "MASTER" for master volume control or "INDIVIDUAL" for individual part/voice volume control.

	SONG	ACHP	H.PAD	LEFT	R1	R2	R3	MIC
1	VOLUME	✓	✓		✓	✓	✓	✓
2	SM1 : SUSTAIN				✓	✓	✓	✓
3	SM2 : SLOW/FAST				✓	✓	✓	✓
4	SUSTAIN MODE : DEFAULT							

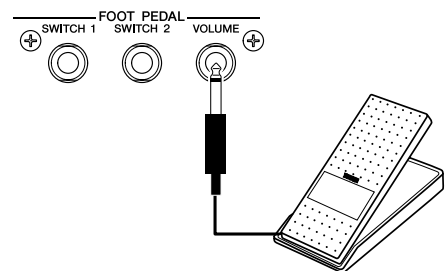

When "INDIVIDUAL" is selected, you can set the individual part/voice to on or off.

The 9000Pro "Functions"

- Footswitch1
- Footswitch2

This determines the functions of footswitches plugged into the rear-panel FOOT PEDAL SWITCH 1 and FOOT PEDAL SWITCH 2 jacks, and to which of the 9000Pro voices the footswitches will apply.

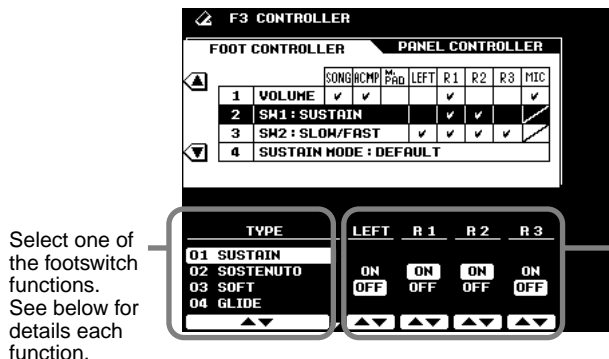

When the Sustain, Sostenuto, Soft, Glide, Portamento, or DSP slow/fast type is selected, you can set the corresponding parts on or off as required.

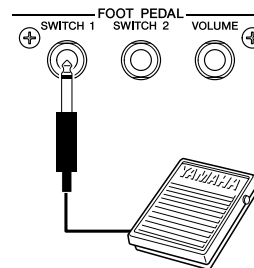

Functions controlled by the footswitch

SUSTAIN	Standard sustain footswitch operation. When the footswitch is pressed notes played have a long sustain. Releasing the footswitch immediately stops (damps) any sustained notes.
SOSTENUTO	If you play a note or chord on the keyboard and press the footswitch while the note(s) are held, those notes will be sustained as long as the footswitch is held (as if the damper pedal had been pressed) but all subsequently played notes will not be sustained. This makes it possible to sustain a chord, for example, while other notes are played "staccato."
SOFT *	Pressing the footswitch subtly reduces the volume and slightly changes the timbre of notes played. The SOFT effect only applies to certain voices — PIANO, for example.
GLIDE **	When the pedal is pressed the pitch drops a semitone, and then glides smoothly back to normal pitch when the pedal is released.
PORTAMENTO	The portamento effect (a smooth slide between notes) can be produced while the pedal is pressed. Portamento is produced when notes are played legato style (i.e., a note is played while the preceding note is still held). The portamento time can be set via the Mixing Console display (page 145).
DSP SLOW/FAST	Same as the DSP [SLOW/FAST] button.
HARMONY/ECHO	Harmony occurs only while pedal is pressed.
VOCAL HARMONY	Same as the [V.H.(9)] button.
REGIST. +	Recall next highest (increment) registration. "1-1" is selected after "64-8".
REGIST. -	Recall next lowest (decrement) registration. "64-8" is selected after "1-1".
START/STOP	Same as the [START/STOP] button.
TAP TEMPO	Same as the [TAP TEMPO] button.
SYNCHRO STOP	Same as the [SYNC STOP] button.
INTRO 1	Same as the [INTRO I] button.
INTRO 2	Same as the [INTRO II] button.
INTRO 3	Same as the [INTRO III] button.
MAIN A	Same as the [MAIN VARIATION A] button.
MAIN B	Same as the [MAIN VARIATION B] button.
MAIN C	Same as the [MAIN VARIATION C] button.
MAIN D	Same as the [MAIN VARIATION D] button.
FILL DOWN	Same as the [FILL IN & BREAK ←] button.
FILL SELF	Same as the [FILL IN & BREAK ↻] button.
FILL BREAK	Same as the [FILL IN & BREAK ↯] button.
FILL UP	Same as the [FILL IN & BREAK →] button.
ENDING 1	Same as the [ENDING/rit. I] button.
ENDING 2	Same as the [ENDING/rit. II] button.
ENDING 3	Same as the [ENDING/rit. III] button.
FADE IN/OUT	Same as the [FADE IN/OUT] button.
FING/ON BASS	The footswitch alternately switches between the Fingered and On Bass modes (page 70).
BASS HOLD	While the pedal is pressed, the Auto Accompaniment bass note will be held even if the chord is changed. This function does not work in the Full Keyboard mode.
PERCUSSION	Footswitch plays a percussion instrument selected by the ASSIGN LCD buttons (the latter appears when the Percussion type is selected).

SYNCHRO START	Same as the [SYNCHRO START] button.
R1 ON/OFF	Same as the [R1] button.
R2 ON/OFF	Same as the [R2] button.
R3 ON/OFF	Same as the [R3] button.
LEFT ON/OFF	Same as the [L] button.
OTS +	Recalls next higher One Touch Setting.
OTS -	Recalls next lower One Touch Setting.

* SOFT does not affect the voice using the PLG150/100-DX board.

** GLIDE does not affect the voice using the Plug-in Board.

● **Sustain Mode**

In the DEFAULT setting, when you press the footswitch for sustain, the notes you play and release sustain and fade out normally.

In the HOLD setting, when you hold down the footswitch for sustain, the notes you play are held (just as if you were actually holding them down with your hands) even if you release the keys.

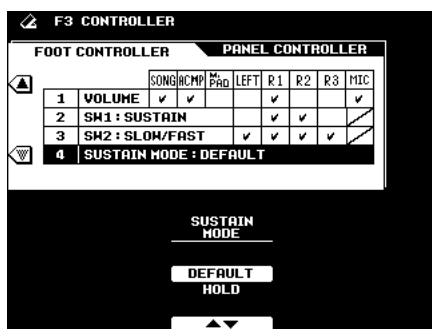

■ **Panel Controller**

● **MODULATION WHEEL**

Determines to which of the 9000Pro voices the MODULATION wheel will apply.

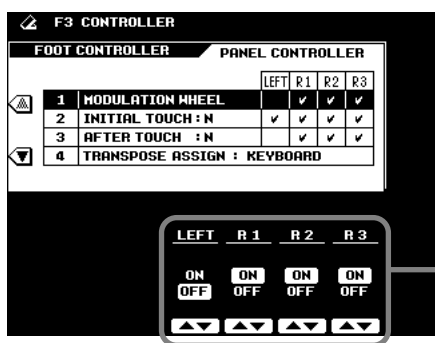

Turn Modulation wheel control for the corresponding parts ON or OFF as required.

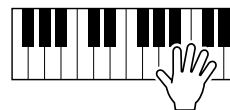
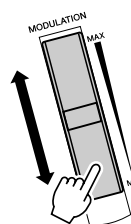

● INITIAL TOUCH

With this function, the 9000Pro senses how strongly or softly you play the keys, and uses that playing strength to affect the sound in various ways, depending on the selected voice. This allows you to play with greater expressiveness and add effects with your playing technique.

Indicates current sensitivity setting.

Set the level at which touch response is turned off.

Turn initial touch response control for the corresponding parts ON or OFF as required.

Select the desired sensitivity curve (listed at right).

HARD 2	Requires the keys to be played very hard to produce maximum loudness.
HARD 1	Requires the keys to be played quite hard to produce maximum loudness.
NORMAL	Produces a fairly standard keyboard response.
SOFT 1	Although this is not as sensitive as the "SOFT 2" setting, this allows you to produce loud volume with relatively light playing strength.
SOFT 2	Allows maximum loudness to be produced with very light playing strength.

● AFTER TOUCH

With this function, the 9000Pro senses how much pressure you apply to the keys while playing, and uses that pressure to affect the sound in various ways, depending on the selected voice. This allows you to play with greater expressiveness and add effects with your playing technique.

Indicates current sensitivity setting.

Turn aftertouch for the corresponding parts ON or OFF as required.

Select the desired sensitivity curve listed at the right side.

HARD	Relatively strong after touch pressure is needed to produce changes.
NORMAL	Produces a fairly standard after touch response.
SOFT	Allows you to produce relatively large changes with very light after touch pressure.

● TRANSPOSE ASSIGN

This determines the function of the [TRANPOSE] buttons (page 61).

When set to "KEYBOARD" (default), the buttons transpose only the keyboard sound.
 When set to "SONG," the buttons transpose only the song playback.
 When set to "MASTER," the buttons transpose the overall pitch of the 9000Pro.

Registration/Freeze Group/Voice Set Settings

The explanations here apply to step #3 of the Basic Procedure on page 158.

■ Registration

You can enter descriptive names for each registration bank/number via the Name function.

Quick Guide on page 28



Press one of these buttons to change the name of the Bank or Registration.

For information about how to enter the name, refer to the Basic Operation (page 46).

Select a registration bank/number you wish to name.

■ Freeze Group

You can specify which settings are affected by the Freeze function (page 28) via this function.

Quick Guide on page 28

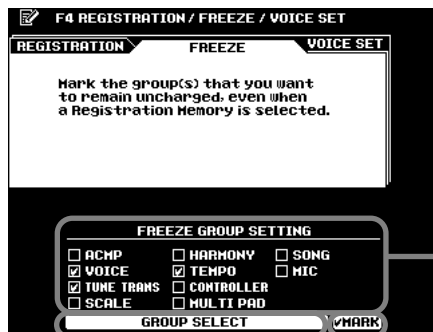

Selects a setting you want to freeze or "un-freeze."

The parameters included in each group are listed on page 214.

Set (mark) or remove (un-mark) the selected setting.

■ Voice Set

This function determines whether or not the preset Voice, Effect, EQ, and Harmony type settings assigned to each preset voice are recalled when a new voice is selected.

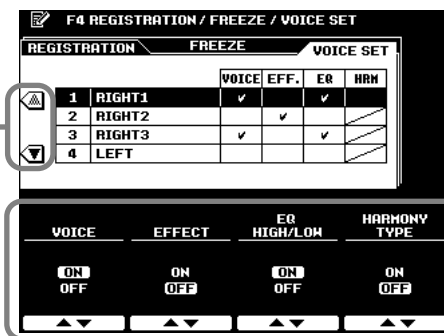

Select a part.

These four sets can be individually turned ON or OFF for each part (RIGHT1, 2, 3, LEFT).

NOTE
• The VOICE, DSP, EQ, and HARMONY TYPE parameters are listed on page 214.

Harmony/Echo Settings

Quick Guide on page 35

The explanations here apply to step #3 of the Basic Procedure on page 158.

F5 HARMONY / ECHO

- TYPE:** 01 STANDARD DUET, 02 STANDARD TRIO, 03 FULL CHORD, 04 ROCK DUET, 05 COUNTRY DUET, 06 COUNTRY TRIO, 07 BLOCK, 08 4-MAY CLOSE1, 09 4-MAY CLOSE2, 10 4-MAY OPEN, 11 1+5, 12 OCTAVE, 13 STRUM, 14 MULTI ASSIGN, 15 ECHO, 16 TREMOLO, 17 TRILL.
- VOLUME:** 72
- SPEED:** [Slider]
- ASSIGN:** AUTO, MULTI, R1, R2, R3
- CHORD NOTE ONLY:** ON, OFF
- TOUCH LIMIT:** 0

Assign the Harmony effect to the various parts as listed below.

Determines the lowest velocity value at which the harmony note will sound. The higher the value, the harder the keyboard must be played to apply the Harmony effect.

When set to ON, the Harmony effect is applied only to the note that belongs to a chord played on the left side of the keyboard from the split point. This setting is not available when the Multi Assign, Echo, Tremolo, or Trill type is selected.

Select a Harmony type. See below for details.

Set the volume of the Harmony effect.

Adjust the speed of the echo/tremolo/trill effect. This parameter is active when any of the echo-based effects are selected (15 through 17).

About the Harmony types

- When a Harmony type ("STANDARD DUET" through "STRUM") is selected

A chord played on the left side of the keyboard from the split point controls the harmony.

This type automatically adds one or more harmony notes to a single-note melody played on the right side of the keyboard from the split point.

- When "MULTI ASSIGN" is selected

Multi Assign automatically assigns notes played simultaneously on the right-hand section of the keyboard to separate parts (voices). The number of parts which can be assigned depends on the number of parts turned ON via the [PART ON/OFF] buttons. If three parts are turned on, then up to three voices can be assigned. If two parts are turned on, then only two voices can be assigned. For example, if the R1, R2, and R3 parts are turned on and you play and hold three successive notes, the first note will be played with the R1 voice, the second note with the R2 voice, and the third note with the R3 voice.

- When "ECHO" is selected

An echo effect is applied to the note played on the keyboard at the currently set tempo.

- When "TREMOLO" is selected

A tremolo effect is applied to the note played on the keyboard at the currently set tempo.

- When "TRILL" is selected

Two notes held on the keyboard are played alternately at the currently set tempo.

NOTE

For all voices except Organ Flutes and Plug-in voices, if you change the chord in your left hand while holding down a note with your right hand, the pitch of the harmony note(s) will bend (without attack) to match the newly played chord. When using Organ Flutes or Plug-in voices with your right hand, the harmony note(s) is retriggered with a fresh attack at a new pitch matching the newly played chord.

NOTE

The echo, tremolo, and trill effects set via the Harmony/Echo function may not affect the Organ Flutes sound and the Plug-in voice as expected.

About "ASSIGN"

- R1 Harmony is only applied to the R1 part. If R1 is OFF there will be no Harmony effect.
- R2 Harmony is only applied to the R2 part. If R2 is OFF there will be no Harmony effect.
- R3 Harmony is only applied to the R3 part. If R3 is OFF there will be no Harmony effect.
- AUTO Harmony notes are automatically assigned to the R1, R2, and R3 parts, in that order or priority.
- MULTI Multi Assign automatically assigns the 1st, 2nd, and 3rd added harmony notes to separate parts (voices). For example, if the R1, and R2 parts are turned on and the STANDARD DUET type is selected, then the note you play on the keyboard will be played by the R1 voice, and the added harmony note will be played by the R2 voice.

Video Monitor Settings

The functions on this page let you set the display characteristics for the lyrics and chords (page 79) that are output to a television or video monitor connected to the [VIDEO OUT] jack (page 13).

You can set the size and color of the displayed characters, as well as the color of the display background.

The explanations here apply to step #3 of the Basic Procedure on page 158.



You can set the background to one of four colors.

The characters displayed on the video screen can be set to any of a variety of colors.

Set this to "SMALL" if the contents of the LCD do not fit in the monitor screen.

Set this to correspond to the standard (NTSC or PAL) used by your video equipment. The default setting is "PAL." If the standard used by your television or video monitor is not PAL (for example, NTSC is generally used in North America), change the setting to "NTSC." This setting is retained in memory as part of the System Backup parameters. (See pages 55 and 214)

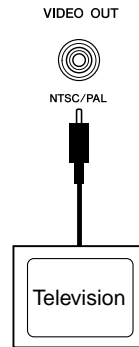

NOTE

- Occasionally some flashing parallel lines may appear in the television or video monitor. This does not indicate that the television or video monitor is malfunctioning; you may be able to remedy the situation by adjusting the Character Color or Background Color parameters. For optimum results, also try adjusting the color settings on the TV monitor itself.
- Avoid looking at the television or video monitor for prolonged periods of time since doing so could damage your eyesight. Take frequent breaks and/or focus your eyes on distant objects to avoid eyestrain.

NOTE

- Keep in mind that even after adjusting all settings as recommended here, the TV monitor you are using may not display the LCD contents as expected (e.g., the LCD contents may not fit on the screen, the characters may not be completely clear, or the colors may be wrong).

Talk Setting

This function page includes a number of parameters which affect the microphone sound when the [TALK] button is on.

The explanations here apply to step #3 of the Basic Procedure on page 158.



This determines the amount of attenuation to be applied to the overall sound (not including the microphone input).

These set the reverb and chorus depth of the microphone sound.

This sets the stereo pan position of the microphone sound.

This determines the volume or level of your voice from the microphone.

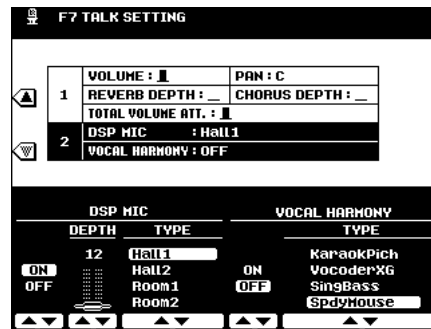

This is the same parameter as the Vocal Harmony type described on page 81. When the [TALK] button is turned on, the current type setting is recalled.

This turns Vocal Harmony ON or OFF.

This selects the type of DSP effect to be applied to the microphone sound.

This sets the depth of the DSP effect applied to the microphone sound.

This turns the DSP effect applied to the microphone sound ON or OFF.

Utility Settings

The explanations here apply to step #3 of the Basic Procedure on page 158.

■ Configuration

● 1, 2

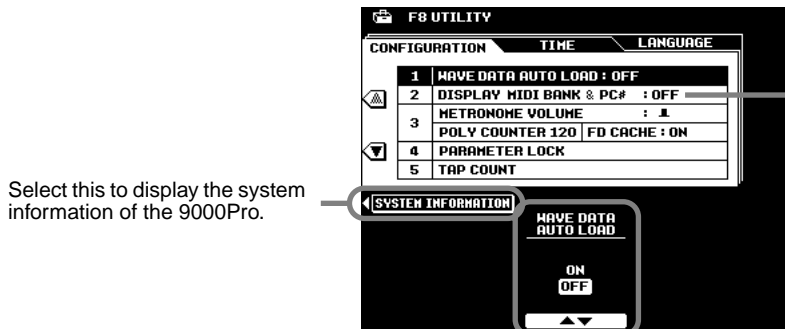

This determines whether all wave data that was in the wave RAM memory when the power was previously turned off will be automatically reloaded from disk when the 9000Pro power is turned on.

● 3

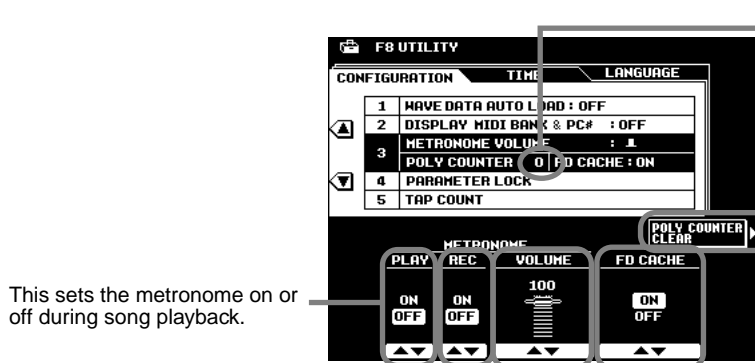

This sets the metronome on or off during song playback.

This sets the metronome on or off during song recording.

This sets the volume of the 9000Pro metronome sound for recording.

Setting this to ON enables the 9000Pro to read data much faster from the floppy disk. This is done by use of built-in cache memory. When a floppy disk is inserted and this is set to ON, the 9000Pro automatically loads data to the cache memory (even when you play the keyboard, accompaniment, Multi Pads, etc.). All data is then read directly from the cache memory rather than the disk, vastly speeding up the reading of floppy disk data.

This indicates the maximum number of notes currently being played. This can be useful in checking whether the maximum polyphony has been exceeded in songs or styles. The maximum value is 126 (the 9000Pro's maximum polyphony). Please note that the polyphony of the Plug-in Voices is not counted.

Press this to reset the Poly Counter to "0".

● 4, 5

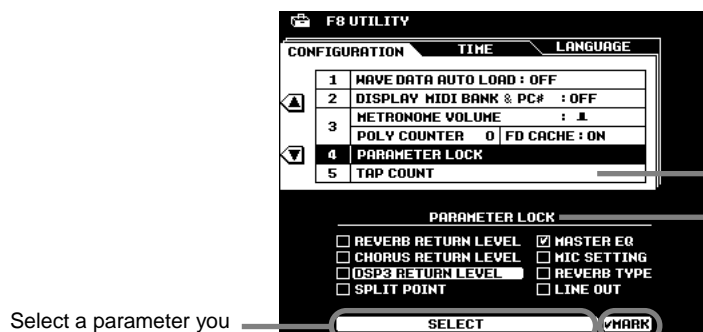

Select a parameter you want to lock or unlock.

This allows you to set the drum voice and the velocity which will sound when the Tap function (page 72) is used.

This function can be used to "lock" the specified parameters so that they can only be changed via the direct panel controls (i.e., not via the Registration Memory, One Touch Setting, Music Database, MIDI, sequence data, etc.).

Lock (mark) or unlock (un-mark) the selected parameter.

■ Time

The displays from which voices and styles are selected automatically change back to the previously selected display after a short time. (when this is not set to "NEVER"). The Auto Exit Time parameter determines the time that the Voice List or Style List displays remain before returning to the previous display. When this is set to "NEVER," the Voice List or Style List displays remain indefinitely. (You can manually return to the previous display by pressing the [EXIT] button.)

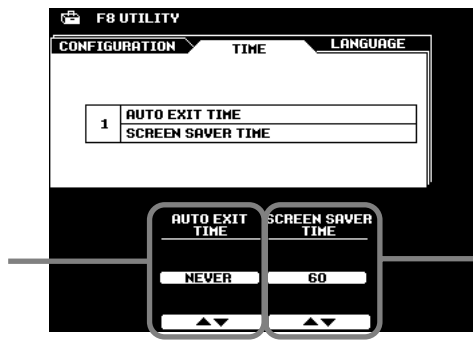

When this is set to "NEVER," the selected menu displays remain indefinitely until changed manually. When set to a value other than "NEVER," the displays change according to the interval selected.

Screen Saver Time determines how much time elapses before the Screen Saver function is turned on. The Screen Saver cancels the current display and scrolls through the 9000Pro's specifications. To return to the original display, press the [CLOSE] LCD button (which appears in the Screen Saver) or any other panel button.

■ Language



NOTE
 • Keep in mind that some keys of the computer keyboard are not used for the 9000Pro and have no effect or function.

Press this button to enter the owner's (your) name.

See page 45 for details.

Select the appropriate type for the computer keyboard that is to be connected to the 9000Pro. See below for details.

● Computer Keyboard Types (for use with the 9000Pro)

• Type 1

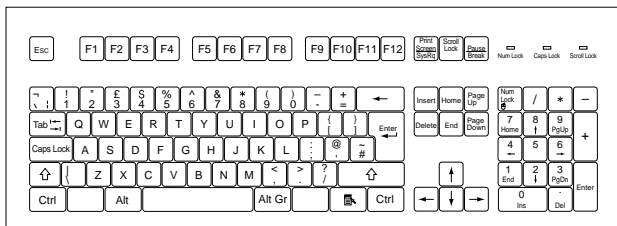

• Type 2

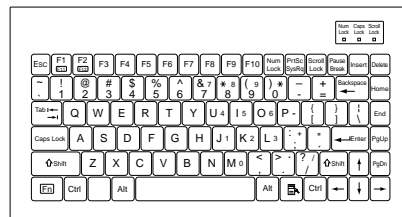

• Type 3

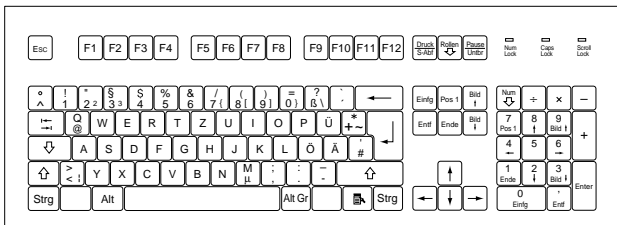

• Type 4

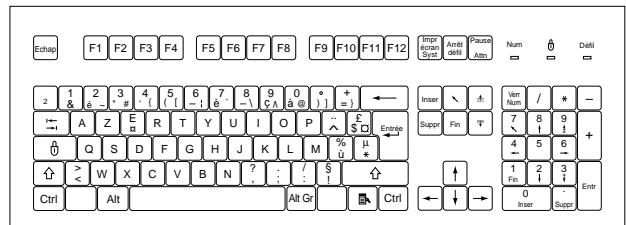

• Type 5

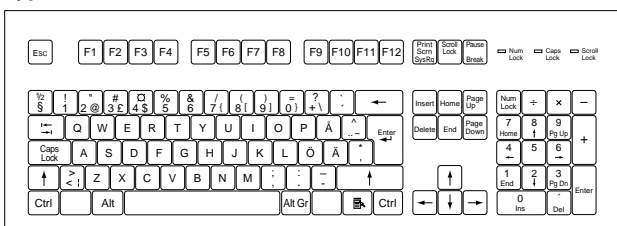

• Type 6

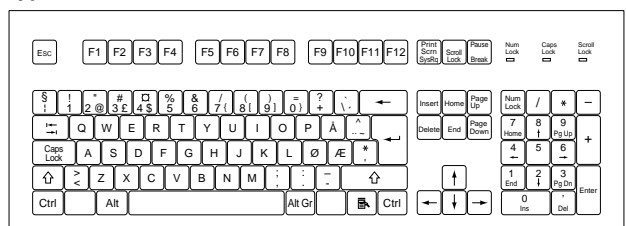

MIDI Functions

Built into the rear panel of the 9000Pro are two standard sets to MIDI terminals (MIDI IN A/B, MIDI OUT A/B), a TO HOST terminal, and a HOST SELECT switch. The MIDI Functions give you a comprehensive, powerful set of tools for expanding your music recording and performance possibilities.

This section explains what MIDI is, and what it can do, as well as how you can use MIDI on your 9000Pro.

What's MIDI?

No doubt you have heard the terms “acoustic instrument” and “digital instrument.” In the world today, these are the two main categories of instruments. Let's consider an acoustic piano and a classical guitar as representative acoustic instruments. They are easy to understand. With the piano, you strike a key, and a hammer inside hits some strings and plays a note. With the guitar, you directly pluck a string and the note sounds. But how does a digital instrument go about playing a note?

● Acoustic guitar note production

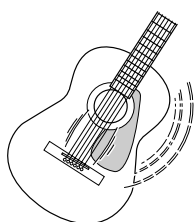

Pluck a string and the body resonates the sound.

● Digital instrument note production

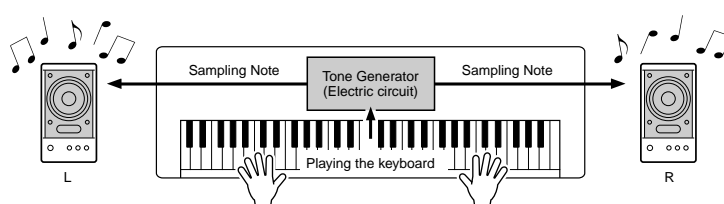

Based on playing information from the keyboard, a sampling note stored in the tone generator is played through the speakers.

As shown in the illustration above, in an electronic instrument the sampling note (previously recorded note) stored in the tone generator section (electronic circuit) is played based on information received from the keyboard. So then what is the information from the keyboard that becomes the basis for note production?

For example, let's say you play a “C” quarter note using the grand piano sound on the 9000Pro keyboard.

Unlike an acoustic instrument that puts out a resonated note, the electronic instrument puts out information from the keyboard such as “with what voice,” “with which key,” “about how strong,” “when was it pressed” and “when was it released.” Then each piece of information is changed into a number value and sent to the tone generator.

Using these numbers as a basis, the tone generator plays the stored sampling note.

● Example of Keyboard Information

Voice number (with what voice)	01 (grand piano)
Note number (with which key)	60 (C3)
Note on (when was it pressed) and note off (when was it released)	Timing expressed numerically (quarter note)
Velocity (about how strong)	120 (strong)

MIDI is an acronym that stands for Musical Instrument Digital Interface, which allows electronic musical instruments to communicate with each other, by sending and receiving compatible Note, Control Change, Program Change and various other types of MIDI data, or messages.

The 9000Pro can control a MIDI device by transmitting note related data and various types of controller data. The 9000Pro can be controlled by the incoming MIDI messages which automatically determine tone generator mode, select MIDI channels, voices and effects, change parameter values and of course play the voices specified for the various parts.

MIDI messages can be divided into two groups: Channel messages and System messages. Below is an explanation of the various types of MIDI messages which the 9000Pro can receive/transmit.

● Channel Messages

The 9000Pro is an electronic instrument that can handle 32 channels. This is usually expressed as “it can play 32 instruments at the same time.” Channel messages transmit information such as Note ON/OFF, Program Change, for each of the 32 channels.

Message Name	9000Pro Operation/Panel Setting
Note ON/OFF	Messages which are generated when the keyboard is played. Each message includes a specific note number which corresponds to the key which is pressed, plus a velocity value based on how hard the key is played.
Program Change	Voice selecting (control change bank select MSB/LSB setting)
Control Change	Volume, panpot (Mixing Console), etc.

● System Messages

This is data that is used in common by the entire MIDI system. System messages include messages like System Exclusive Messages that transmit data unique to each instrument manufacturer and Realtime Messages that control the MIDI device.

Message Name	9000Pro Operation/Panel Setting
System Exclusive Message	Effect type settings (Mixing Console), etc.
Realtime Messages	Clock setting, Start/stop operation

NOTE

- The performance data of all songs, styles and Multi Pads is MIDI data.

The messages transmitted/received by the 9000Pro are shown in the MIDI Data Format and MIDI Implementation Chart on pages 228 and 244.

■ MIDI and TO HOST Terminals

In order to exchange MIDI data between multiple devices, each device must be connected by a cable.

There are two ways to connect: from the MIDI terminals of the 9000Pro to the MIDI terminals of an external device using a MIDI cable, or from the TO HOST port of the 9000Pro to the serial port of a personal computer using a special cable.

If you connect from the 9000Pro TO HOST terminal to a personal computer, the 9000Pro will be used as a MIDI interface, meaning that a dedicated MIDI interface is not necessary.

In the rear panel of the 9000Pro, there are two kinds of terminals, the MIDI terminals and the TO HOST terminal.

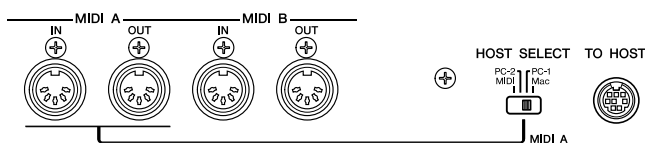

MIDI IN	Receives MIDI data from another MIDI device.
MIDI OUT	Transmits the 9000Pro's keyboard information as MIDI data to another MIDI device.
TO HOST	Transmits and receives MIDI data to and from a personal computer.

The MIDI A terminals and the TO HOST terminal are mutually exclusive; they cannot be used at the same time. Use the HOST SELECT switch to change between the MIDI A terminals and the TO HOST terminal.

When the HOST SELECT switch is set to “MIDI,” the MIDI A terminals receive/transmit MIDI data. When the HOST SELECT switch is set to “Mac,” “PC-1,” or “PC-2,” the MIDI A terminals will not receive/transmit data.

The MIDI B IN/OUT terminals function regardless of the setting of the HOST SELECT switch.

NOTE

- When using the TO HOST terminal to connect to a personal computer using Windows 95/98, a Yamaha MIDI driver must be installed in the personal computer. The included disk contains the Yamaha MIDI driver.
- Special MIDI cables (sold separately) must be used for connecting to MIDI devices. They can be bought at music stores, etc.
- Never use MIDI cables longer than about 15 meters. Cables longer than this can pick up noise which can cause data errors.

NOTE

- The MIDI B port ignores System Exclusive messages.

MIDI Functions

On the 9000Pro, 16 channels of MIDI data can be transmitted/received over a single MIDI cable, or over a serial cable (using the TO HOST terminal). Since the 9000Pro features two independent MIDI “ports” (A and B), a total of 32 MIDI channels can be used simultaneously.

For example, several tracks can be transmitted simultaneously, including the auto accompaniment data (as shown below).

● When recording performance data using the Auto Accompaniment on an external sequencer

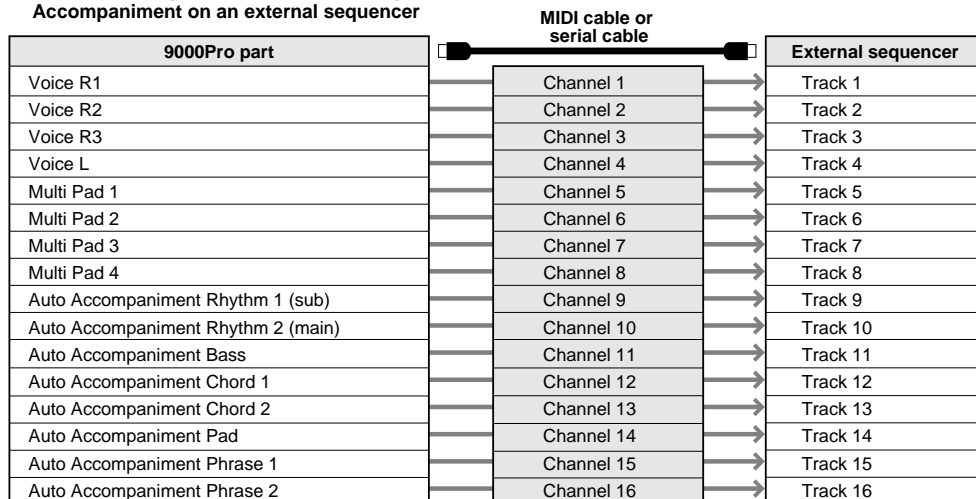

NOTE

- Although the 9000Pro can receive MIDI data over 32 channels simultaneously, as a multi-timbral sound source/ tone generator it actually responds to only 28 channels simultaneously. This is because the MIDI Receive Mode for the MIDI B port (page 176) cannot be set to “XG/GM.”

As you can see, it is essential to determine which data is to be sent over which MIDI channel when transmitting MIDI data (page 175).

What You Can Do With MIDI

- Record performance data (1-16 channels) using the 9000Pro Auto Accompaniment features on a external sequencer (such as a personal computer). After recording, you can then edit the data with the sequencer, then play it again on the 9000Pro (playback).

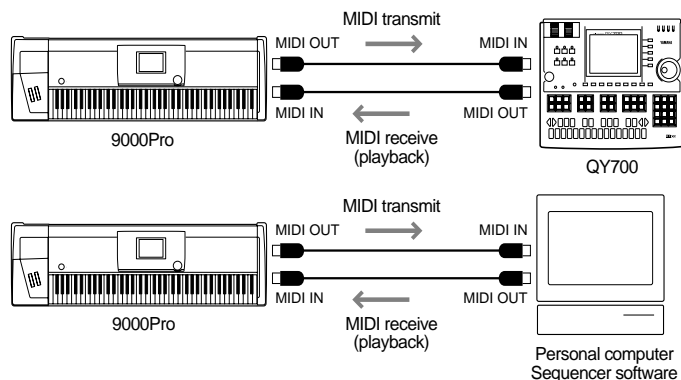

Set: MIDI transmit settings (page 175)
 Set: Receive mode for all channels to “XG/GM”
 MIDI receive settings (page 176)

- Control the 9000Pro from an optional Yamaha MFC10 MIDI Foot Controller

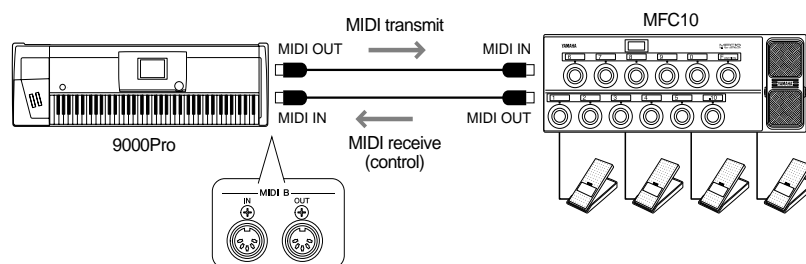

Set: MFC10 settings (page 178).

MIDI Data Compatibility

This section covers basic information on data compatibility: whether or not other MIDI devices can playback the data recorded by 9000Pro, and whether or not the 9000Pro can playback commercially available song data or song data created for other instruments or on a computer.

Depending on the MIDI device or data characteristics, you may be able to play back the data without any problem, or you may have to perform some special operations before the data can be played back. If you run into problems playing back data, please refer to the information below.

■ Sequence format

“Sequence format” refers to the way in which MIDI data (for playback, such as songs and styles) is stored to disk. A number of popular sequence formats described below are compatible with the 9000Pro.

Playback is only possible when the sequence format of the disk matches that of the MIDI device.

SMF (Standard MIDI File)

This is the most common sequence format.

Standard MIDI Files are generally available as one of two types: Format 0 or Format 1. Many MIDI devices are compatible with Format 0, and most commercially available software is recorded as Format 0.

- The 9000Pro is compatible with both Format 0 and Format 1.
- Song data recorded on the 9000Pro is automatically recorded as SMF Format 0.

ESEQ

This sequence format is compatible with many of Yamaha's MIDI devices, including the Clavinova series instruments. This is a common format used with various Yamaha software.

- The 9000Pro is compatible with ESEQ.



XF

The Yamaha XF format enhances the SMF (Standard MIDI File) standard with greater functionality and open-ended expandability for the future.

- The 9000 is capable of displaying lyrics when an XF file containing lyric data is played.



Style File

The Style File Format — SFF — is Yamaha's original style file format which uses a unique conversion system to provide high-quality automatic accompaniment based on a wide range of chord types.

- The 9000Pro uses the SFF internally, reads optional SFF style disks, and creates SFF styles using the Style recording feature.

■ Voice allocation format

With MIDI, voices are assigned to specific numbers, called “program numbers.” The numbering standard (order of voice allocation) is referred to as the “voice allocation format.”

Voices may not play back as expected unless the voice allocation format of the song data matches that of the compatible MIDI device used for playback.



GM System Level 1

This is one of the most common voice allocation formats.

Many MIDI devices are compatible with GM System Level 1, as is most commercially available software.

- The 9000Pro is compatible with GM System Level 1.



XG

XG is a major enhancement of the GM System Level 1 format, and has been developed by Yamaha specifically to provide more voices and variations, as well as greater expressive control over voices and effects, and to ensure compatibility of data well into the future.

- The 9000Pro is compatible with XG.



DOC

This voice allocation format is compatible with many of Yamaha's MIDI devices, including the Clavinova series instruments.

This is also a common format used with various Yamaha software.

- The 9000Pro is compatible with DOC.

NOTE

- Even if the devices and data used satisfy all the conditions above, keep in mind that the sounds may differ slightly, depending on the particular MIDI device used for playback (this includes the 9000Pro).

Connecting to a Personal Computer

Connecting the 9000Pro to a computer (via the TO HOST terminal or the MIDI terminals) lets you take advantage of the enormous processing power and editing flexibility of computer-generated music.

Connection can be done in one of two ways:

- Using the 9000Pro MIDI terminals
- Using the TO HOST terminal

■ Using the 9000Pro MIDI terminals

Using a MIDI interface device installed in the personal computer, connect the MIDI terminals of the personal computer and the 9000Pro.

For the connection cable, use a special MIDI cable.

- When the computer has a MIDI interface installed, connect the MIDI OUT terminal of the personal computer to the MIDI IN terminal of the 9000Pro. Set the HOST SELECT switch to "MIDI."

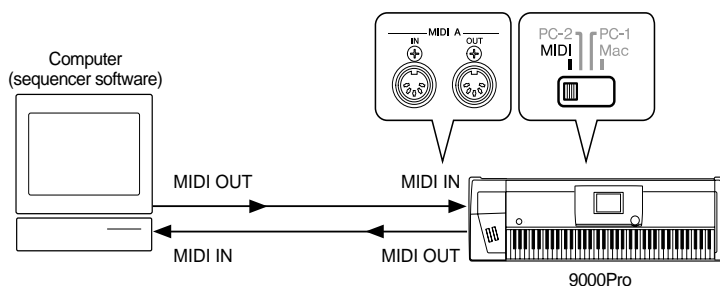

- When using a MIDI interface with a Macintosh series computer, connect the RS-422 terminal of the computer (modem or printer terminal) to the MIDI interface, then connect the MIDI OUT terminal on the MIDI interface to the MIDI IN terminal of the 9000Pro, as shown in the diagram below. Set the HOST SELECT switch on the 9000Pro to "MIDI."

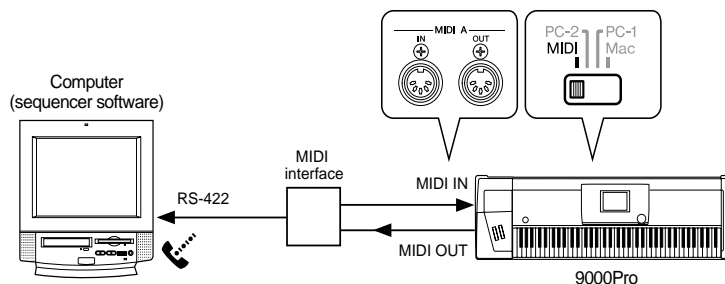

- When the HOST SELECT switch is set in the "MIDI" position, input and output to the TO HOST terminal is ignored.
- When using a Macintosh series computer, set the MIDI interface clock setting in the application software to match the setting of the MIDI interface you are using. For details, carefully read the owner's manual for the software you are using.
- When the computer has a USB interface, use the Yamaha UX256.

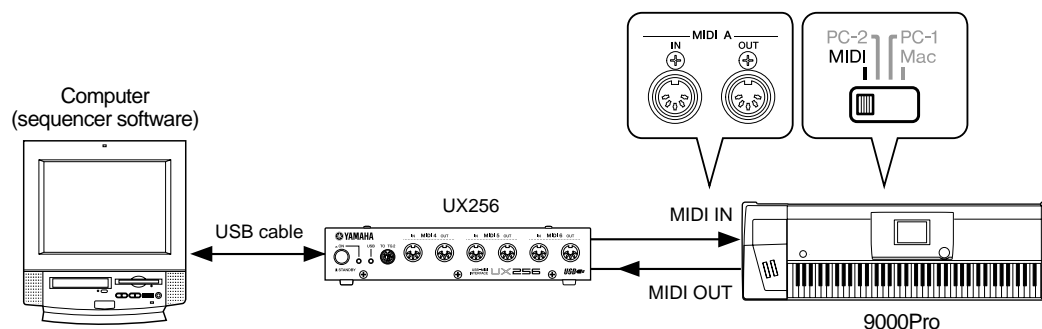

NOTE

- In the explanation examples here, the MIDI A terminals are used.
- When using the 9000Pro as a 16-channel multi-timbral sound source, make sure to connect the other MIDI device to the MIDI A IN terminal (not MIDI B).
- You can connect a MIDI device to the MIDI B IN terminal; however, in this case, the 9000Pro cannot be used as a multi-timbral sound source, since the MIDI Receive Mode for the MIDI B port (page 176) cannot be set to "XG/GM."

Using the TO HOST terminal

Connect the serial port of the personal computer (RS-232C terminal or RS-422 terminal) to the TO HOST terminal of the 9000Pro.

For the connection cable, use the appropriate cable below (sold separately) that matches the personal computer type.

IBM-PC/AT Series

Connect the RS-232C terminal on the computer to the TO HOST terminal on the 9000Pro using a serial cable (D-SUB 9P -> MINI DIN 8P cross cable). Set the 9000Pro HOST SELECT switch to the "PC-2" position.

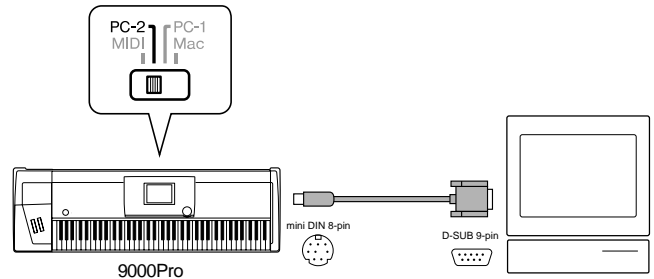

Macintosh Series

Connect the RS-422 terminal (modem or printer terminal) on the computer to the TO HOST terminal on the 9000Pro using a serial cable (system peripheral cable, 8 bit). Set the 9000Pro HOST SELECT switch to the "Mac" position. Set the MIDI interface clock in the sequencer software you are using to 1 MHz. For details, carefully read the owner's manual for the software you are using. For details about the necessary MIDI settings for computer and sequence software you are using, refer to the relevant owner's manuals.

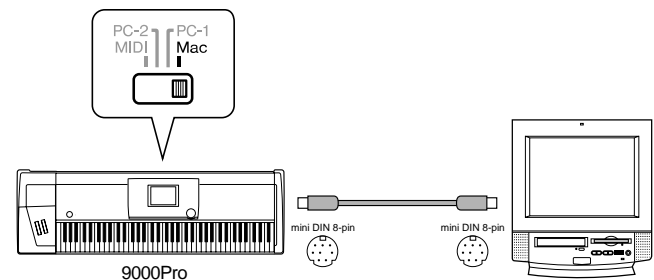

About the Thru Port Function

This function can be used when a computer is connected to the TO HOST terminal of the 9000Pro. It gives you exceptionally flexible and comprehensive control over the routing of incoming MIDI data.

For example, you could use this to selectively play back parts of song data from a computer — having the 9000Pro respond to certain parts of the song, while playing back other parts on a separate connected tone generator (as shown in the illustration).

Select the desired THRU PORT settings from the MIDI SYSTEM display (page 174) on the 9000Pro as described below, and make the appropriate port settings on your computer/sequencer software.

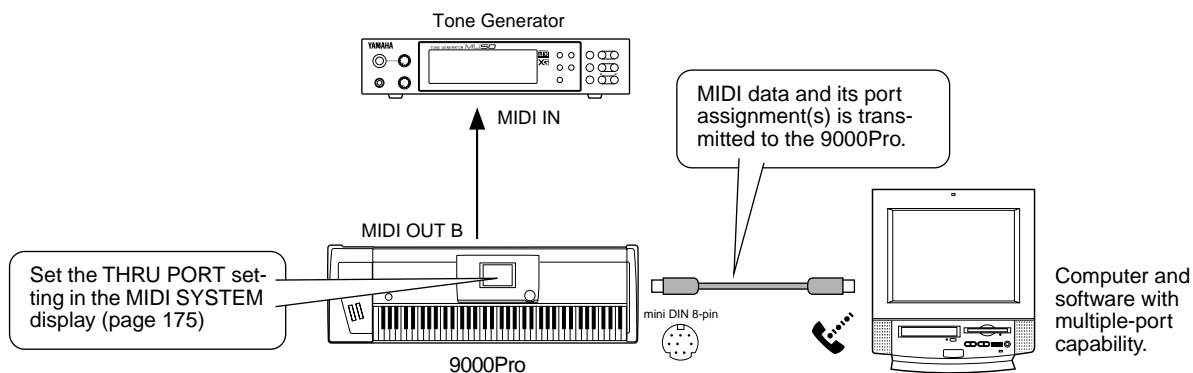

THRU PORT	Comments
NO THRU	All incoming MIDI data from the computer is recognized by the 9000Pro, but is not transmitted through the MIDI B OUT terminal.
THRU	All incoming MIDI data from the computer is recognized by the 9000Pro and is also transmitted unprocessed through the MIDI B OUT terminal. In this case, the MIDI B OUT terminal functions as MIDI THRU.
OFF	Only MIDI data assigned to Port 1 from the computer is recognized by the 9000Pro. The data is not transmitted through the MIDI B OUT terminal. Any MIDI data that is assigned to ports other than Port 1 is not recognized or transmitted.
1-8	Only MIDI data assigned to Port 1 from the computer is recognized by the 9000Pro. The data that is assigned to the port number set here is transmitted through the MIDI B OUT terminal. Any MIDI data that is assigned to ports other than the one selected here and Port 1 is not recognized or transmitted.

The 9000Pro offers a range of MIDI functions that allow it to be used effectively in even the most sophisticated MIDI systems.

Basic Procedure

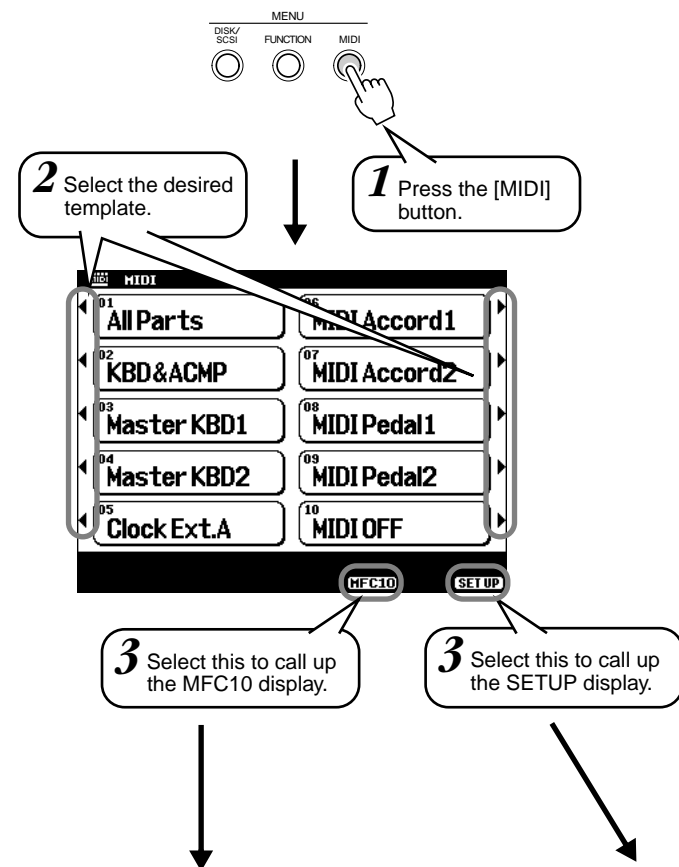

Preset MIDI templates (Factory Set)

All Parts	Transmits all parts including R1, R2, R3 and Left.
KBD & ACMP	Transmits Upper and Lower keyboard performance data, rather than that of the individual parts (R1, R2, R3, and Left).
Master KBD1	The 9000Pro functions as a master keyboard for controlling external tone generators or other devices.
Master KBD2	The 9000Pro functions as a master keyboard which does not transmit aftertouch data.
Clock Ext.A	MIDI IN A port receives MIDI clock data, allowing you to synchronize the 9000Pro with an external MIDI device.
MIDI Accord1	An ideal setup for controlling the keyboard and accompaniment by a MIDI accordion.
MIDI Accord2	The chord and bass buttons on a MIDI accordion are used to control the accompaniment, as well as play the chord and bass parts.
MIDI Pedal1	A MIDI pedal keyboard connected to the MIDI IN B port controls the bass note of the accompaniment.
MIDI Pedal2	A MIDI pedal keyboard connected to the MIDI IN B port plays the bass part.
MIDI OFF	No MIDI signals are sent or received.

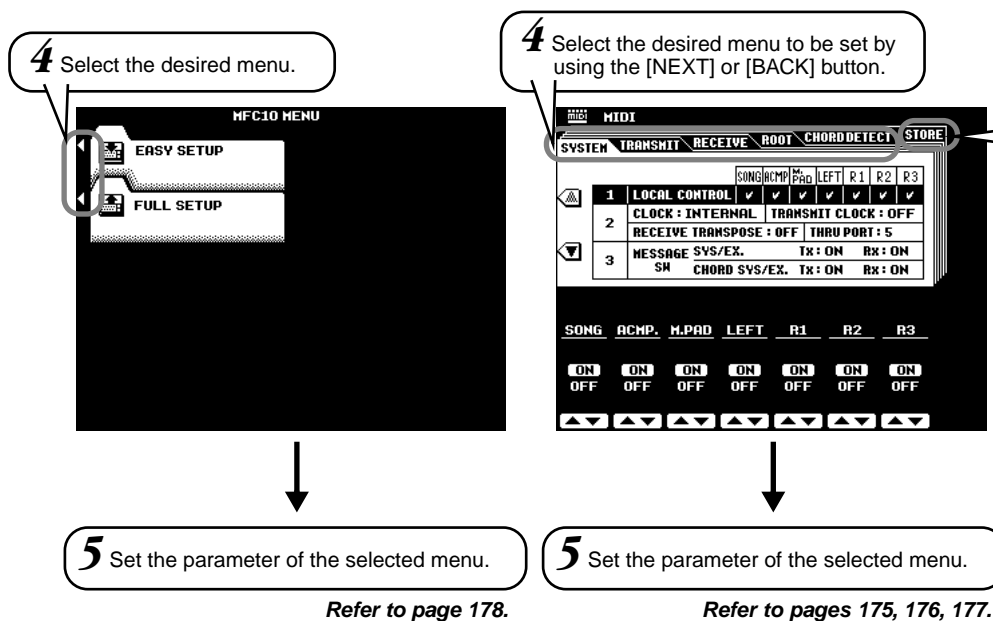

NOTE

• Since all MIDI settings data is stored to Flash ROM, any data in the MIDI settings location will be erased and replaced by your new settings. This includes the factory programmed preset MIDI settings. If you've deleted the factory-set data, you can use the Restore function (page 154) to load a copy of it from the included disks (page 6).

The operations for each function corresponding to step #5 or #6 are covered in the following explanations.

System Settings

The explanations here apply to step #5 of the Basic Procedure on page 174.

Local Control

“Local Control” refers to the fact that, normally, the 9000Pro keyboard controls the internal tone generator, allowing the internal voices to be played directly from the keyboard. This condition is referred to as “Local Control on” since the internal tone generator is controlled locally by its own keyboard. Local control can be turned off, however, so that the keyboard does not play the internal voices, but the appropriate MIDI information is still transmitted via the MIDI OUT connector when notes are played on the keyboard. At the same time, the internal tone generator can respond to MIDI information received on channels set to the “XG/GM” mode via the MIDI IN connector. This means that while an external MIDI sequencer, for example, plays the 9000Pro internal voices, an external tone generator can be played from the 9000Pro keyboard.

Clock, Receive Transpose and Thru Port

Clock

Determines whether the 9000Pro is controlled by its own internal clock or a MIDI clock signal received from an external device. INTERNAL is the normal Clock setting when the 9000Pro is being used alone. If you are using the 9000Pro with an external sequencer, MIDI computer, or other MIDI device, and you want the 9000Pro to be synchronized to the external device, set this function to EXTERNAL. In the latter case, the external device must be connected to the 9000Pro MIDI IN connector, and must be transmitting an appropriate MIDI clock signal.

Transmit Clock

Turns MIDI clock transmission on or off. When set to OFF, no MIDI clock or START/STOP data is transmitted.

Receive Transpose

When the RECEIVE TRANSPOSE parameter is set to OFF, note data received by the 9000Pro is not transposed, and when set to ON, the received note data is transposed according to the current 9000Pro song transpose setting.

Thru See page 173.

Message Switch

The SYS/EX. TRANSMIT parameter turns MIDI transmission of MIDI system exclusive message data on or off. The SYS/EX. RECEIVE parameter turns MIDI reception of MIDI exclusive data generated by external equipment on or off. The CHORD SYS/EX. TRANSMIT parameter turns MIDI transmission of MIDI chord exclusive data (chord detect — root and type) on or off. The CHORD SYS/EX. RECEIVE parameter turns MIDI reception of MIDI chord exclusive data generated by external equipment on or off.

Transmit Settings

This display page allows you to specify which 9000Pro voices and parts will be transmitted via which MIDI channels (there are 32 MIDI channels), and to specify which types of data will be transmitted for each channel. The explanations here apply to step #5 of the Basic Procedure on page 174.



Select a Channel.

Select a Part for the selected channel.

The Tx MONITOR (transmit monitor) indicates when data is being transmitted on any of the 32 MIDI channels: The dots corresponding to each channel (1-32) flash briefly whenever any data is transmitted on the channel(s).

Turn transmission of the specified data type on or off. See the next page for details on the data types.

NOTE

- Channels 1 - 16 are handled with the MIDI A terminals or the TO HOST terminal; channels 17 - 32 with the MIDI B terminals.

Receive Settings

This display page allows you to specify the MIDI receive mode for each 9000Pro MIDI channels, and to specify which types of data will be received via each channel. The explanations here apply to step #5 of the Basic Procedure on page 174.

The Rx MONITOR indicates when data is being received on any of the 32 MIDI channels: The dots corresponding to each channel (1 - 32) flash briefly whenever any data is received on the channel(s).

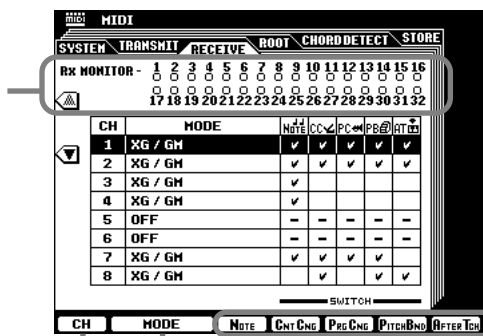

NOTE
 • Channels 1 - 16 are handled with the MIDI A terminals or the TO HOST terminal; channels 1 - 16 of a second MIDI port or device are handled as channels 17 - 32 with the MIDI B terminals.

Turn reception of the specified data type on or off. See below for details on the data types.

Select a Mode for the selected channel. See below for details about the receive modes.
 Select a Channel.

MIDI Receive Mode

OFF	No MIDI data is received.
XG/GM	This is the "Multi-Timbre" mode in which the corresponding channel of the internal XG/GM tone generator is directly controlled by the received MIDI data. XG/GM can only be used with channels 1 - 16. It cannot be used with channels 17 - 32.
RIGHT 1	The RIGHT 1 part is controlled by the MIDI data received on the corresponding channel.
RIGHT 2	The RIGHT 2 part is controlled by the MIDI data received on the corresponding channel.
RIGHT 3	The RIGHT 3 part is controlled by the MIDI data received on the corresponding channel.
LEFT	The LEFT part is controlled by the MIDI data received on the corresponding channel.
KEYBOARD	MIDI note data received by the 9000Pro plays the corresponding notes in the same way as if they are played on the keyboard.
ACMP RHYTHM1~2	The received notes are used as the accompaniment RHYTHM 1 and RHYTHM 2 notes.
ACMP BASS	The received notes are used as the accompaniment BASS notes.
ACMP CHORD1~2	The received notes are used as the accompaniment CHORD 1 and CHORD 2 notes.
ACMP PAD	The received notes are used as the accompaniment PAD notes.
ACMP PHRASE1~2	The received notes are used as the accompaniment PHRASE 1 and PHRASE 2 notes.

Data types in the MIDI TRANSMIT/RECEIVE display

- Note.....Messages which are generated when the keyboard is played.
 Each message includes a specific note number which corresponds to the key which is pressed, plus a velocity value based on how hard the key is played.
- Cntcng.....The abbreviation of "Control Change."
 Control change data includes modulation wheel, foot controller, and any other controller data (except the pitch bend wheel, which has its own switch, below).
- Prgcng.....The abbreviation of "Program Change."
 Program change data corresponds to voice or "patch" numbers.
- Pitch Bend.....Refer to page 59
- After Tch.....Refer to page 60

Root Settings

The note on/off messages received at the channel(s) set to “ON” are recognized as the root notes in the accompaniment section. The root notes will be detected regardless of the accompaniment on/off and split point settings on the 9000Pro panel.

The explanations here apply to step #5 of the Basic Procedure on page 174.

Select channel groups 1 through 8, 9 through 16, 17 through 24, and 25 through 32, respectively.

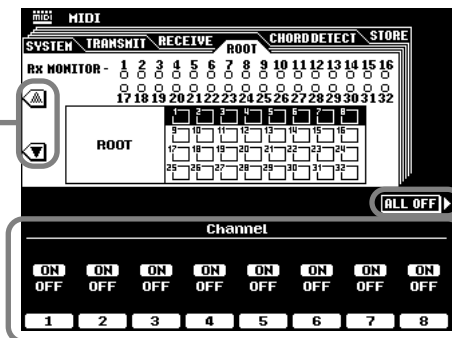

Press this to set all channels to OFF.

Set the desired track to ON or OFF.

NOTE

- Channels 1 - 16 are handled with the MIDI A terminals or the TO HOST terminal; channels 1 - 16 of a second MIDI port or device are handled as channels 17 - 32 with the MIDI B terminals.

NOTE

- When several channels are simultaneously set to “ON,” the root note is detected from merged MIDI data received over the channels.

Chord Detect Settings

The note on/off messages received at the channel(s) set to “ON” are recognized as the fingerings in the accompaniment section. The chords to be detected depend on the fingering mode on the 9000Pro. The chords will be detected regardless of the accompaniment on/off and split point settings on the 9000Pro panel.

The explanations here apply to step #5 of the Basic Procedure on page 174.

Select channel groups 1 through 8, 9 through 16, 17 through 24, and 25 through 32, respectively.

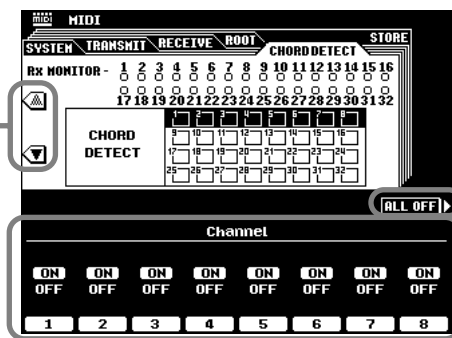

Press this to set all channels to OFF.

Set the desired track to ON or OFF.

NOTE

- Channels 1 - 16 are handled with the MIDI A terminals or the TO HOST terminal; channels 1 - 16 of a second MIDI port or device are handled as channels 17 - 32 with the MIDI B terminals.

NOTE

- When several channels are simultaneously set to “ON,” the chord is detected from merged MIDI data received over the channels.

Storing the MIDI Settings

This allows you to store your custom MIDI settings to Flash ROM.

The explanations here apply to step #6 of the Basic Procedure on page 174.



This allows you to assign a name to your group of MIDI settings. (For details on entering a name, refer to “Basic Operation” on page 46.)

Press this to execute the Store operation.

Select the destination.

NOTE

- Since all MIDI settings data is stored to Flash ROM, any data in the MIDI settings location will be erased and replaced by your new settings. This includes the factory programmed preset MIDI settings. If you’ve deleted the factory-set data, you can use the Restore function (page 154) to load a copy of it from the included disks (page 6).

MFC10 Settings

Various functions can be assigned to an optional Yamaha MFC10 MIDI Foot Controller connected to the 9000Pro.

Connect the MFC10 to the MIDI B terminals and set the MIDI channel for the MFC10 messages by following the on-screen instructions.

The 9000Pro provides two ways to set: Easy Setup and Full Setup.

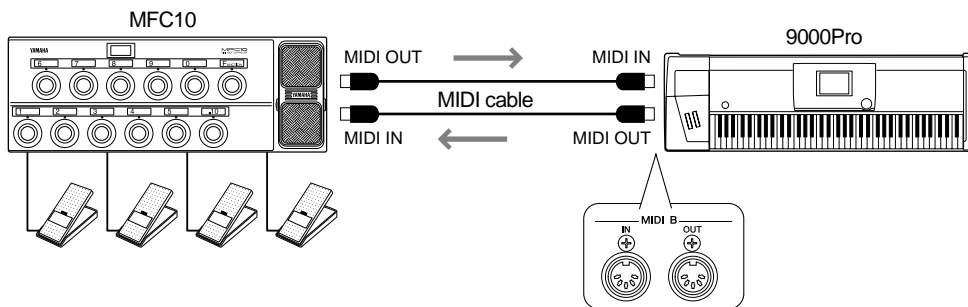

NOTE

- When the MIDI B terminals are connected to the MFC10, the functions of the MIDI B port are limited. For details, refer to the MIDI Data Format (page 228).

The explanations here apply to step #5 of the Basic Procedure on page 174.

Easy Setup

Follow the on-screen instructions to call up the template display as shown below.

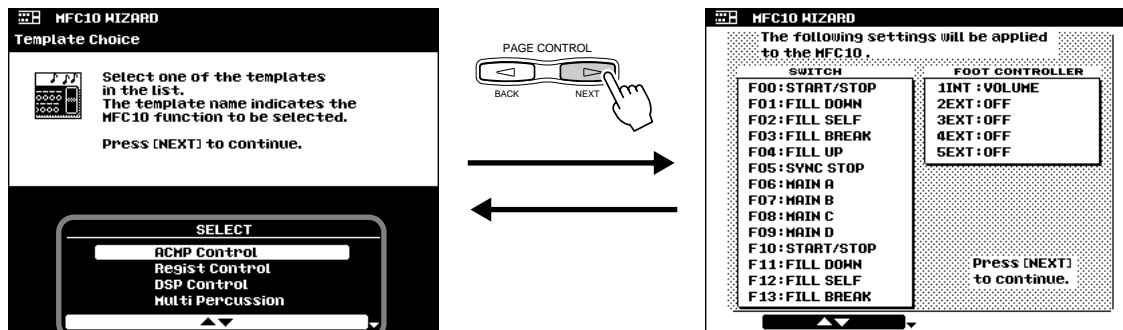

Select a template.

Press the [NEXT] button to enable the selected Easy Setup template. Disconnect the MIDI cable from the MIDI OUT B terminal and connect it to the MFC10 Foot Controller.

NOTE

- When setting up the MFC10 from the 9000Pro, a MIDI cable must be connected from the MIDI OUT of the 9000Pro to the MIDI IN of the MFC10. However, you should disconnect this cable when using the MFC10, since extraneous MIDI messages may be transmitted from the 9000Pro.
- To exit from the MFC10 play mode, select the MIDI Template display (page 174) and press the [CANCEL] LCD button.
- The MFC10 play mode on/off status is retained in Flash ROM and is maintained even when the power is turned off.

Full Setup

You can create your original settings and store them as a template. Follow the on-screen instructions to call up the template display as shown below.



● Assign various functions to the five Foot Controllers.



Select the desired function to be assigned to the selected Foot Controller.
Select the desired Foot Controller.

● Assign various functions to the five Footswitches.



Select the desired function to be assigned to the selected Footswitch.
Select the desired Footswitch number.

● Select the destination template.



Store the MFC10 settings by following the on-screen instructions.

Press the [NEXT] button to enable the selected Easy Setup template. Disconnect the MIDI cable from the MIDI OUT B terminal and connect it to the MFC10 Foot Controller.

NOTE

- Since all MFC10 settings data is stored to Flash ROM, any data in the MFC10 settings location will be erased and replaced by your new settings. This includes the factory programmed preset MFC10 settings. If you've deleted the factory-set data, you can use the Restore function (page 154) to load a copy of it from the included disks (page 6).

NOTE

- When setting up the MFC10 from the 9000Pro, a MIDI cable must be connected from the MIDI OUT of the 9000Pro to the MIDI IN of the MFC10. However, you should disconnect this cable when using the MFC10, since extraneous MIDI messages may be transmitted from the 9000Pro.
- To exit from the MFC10 play mode, select the MIDI Template display (page 174) and press the [CANCEL] LCD button.
- The MFC10 play mode on/off status is retained in Flash ROM and is maintained even when the power is turned off.

Installing Optional Hardware

The following optional units can be installed to the 9000Pro.

● Plug-in Boards

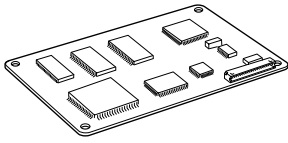

● Hard disk unit

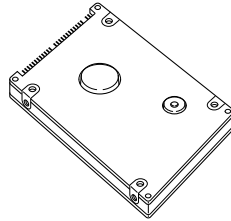

● SIMM

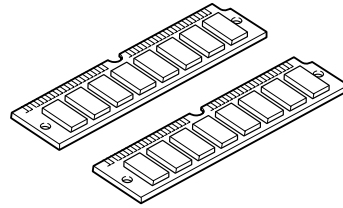

Before installing the optional hardware, make sure you have a Philips screwdriver.

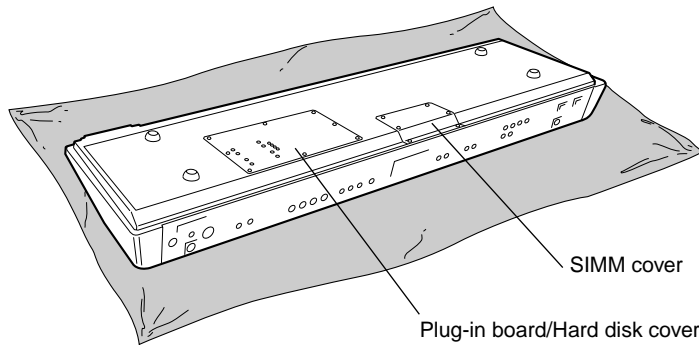

Installation Precautions

⚠ WARNING

- Before beginning installation, switch off the power to the 9000Pro and connected peripherals, and unplug them from the power outlet. Then remove all cables connecting the 9000Pro to other devices. (Leaving the power cord connected while working can result in electric shock. Leaving other cables connected can interfere with work.)
- Be careful not to drop any screws inside the instrument during installation (this can be prevented by keeping the Plug-in Board, hard disk unit and cover away from the instrument while attaching). If this does happen, be sure to remove the screw(s) from inside the unit before turning the power on. Loose screws inside the instrument can cause improper operation or serious damage. If you are unable to retrieve a dropped screw, consult your Yamaha dealer for advice.
- Install the Plug-in boards, the hard disk unit, and the SIMM modules carefully as described in the procedure below. Improper installation can cause shorts which may result in irreparable damage and pose a fire hazard.
- Do not disassemble, modify, or apply excessive force to board areas and connectors on Plug-in boards/hard disk/SIMMs. Bending or tampering with boards and connectors may lead to electric shock, fire, or equipment failures.

⚠ CAUTION

- Before handling the Plug-in boards/hard disk unit/SIMMs, you should briefly touch the metal surface to which the Plug-in board/hard disk or SIMM cover is attached (or other such metallic area — be careful of any sharp edges) with your bare hand so as to drain off any static charge from your body. Note that even a slight amount of electrostatic discharge may cause damage to these components.
- It is recommended that you wear gloves to protect your hands from metallic projections on the Plug-in boards, Hard disk unit, SIMMs, and other components. Touching leads or connectors with bare hands may cause finger cuts, and may also result in poor electrical contact or electrostatic damage.
- Handle the Plug-in boards/Hard disk unit/SIMM with care. Dropping or subjecting them to any kind of shock may cause damage or result in a malfunction.
- Be careful of static electricity. There are times when static electricity affects the IC chips on the Plug-in board. Before you lift the optional Plug-in board, to reduce the possibility of static electricity, touch the metal parts other than the painted area or a ground wire on the devices that are grounded.
- Do not touch the exposed metal parts in the circuit board. Touching these parts may result in a faulty contact.
- When moving a cable, be careful not to let it catch on the circuit Plug-in board. Forcing the cable in anyway may cut the cable, cause damage, or result in a malfunction.
- Be careful not to misplace any of the screws since all of them are used.
- Do not use any screws other than what are installed on the instrument.

Optional Plug-in Board Installation

A variety of optional Plug-in boards sold separately let you expand the voice library of your instrument. The following types of Plug-in boards can be used with your instrument.

- PLG150-AN
- PLG150-PF
- PLG100-VL
- PLG150-VL
- PLG100-DX
- PLG150-DX
- PLG100-XG

⚠ CAUTION

- When inserting Plug-in boards and connecting cables, make sure that you check that they are inserted and connected properly. Improperly inserted Plug-in boards and cables may cause faulty contacts and an electrical short circuit which may cause damage or result in a malfunction.
- After mounting the Plug-in board, be sure to tighten the screws as directed so it is completely stable and does not move in any way.

- ▶ **1** Turn the 9000Pro power off, and disconnect the AC power cord. Also, if the keyboard is connected with other external device(s), disconnect the device(s).
- ▶ **2** Turn the 9000Pro face down on a blanket or some soft surface, giving you direct access to the bottom of the instrument.

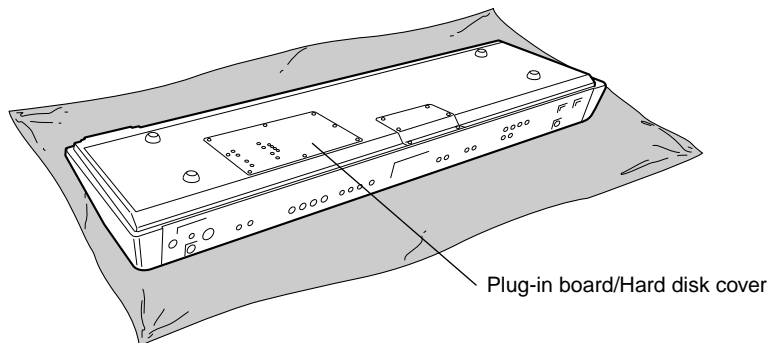

- ▶ **3** Move to a position facing the front panel of the keyboard, and remove the eight screws from the Plug-in board/Hard disk cover with a Phillips screwdriver. Do not remove the other screws.

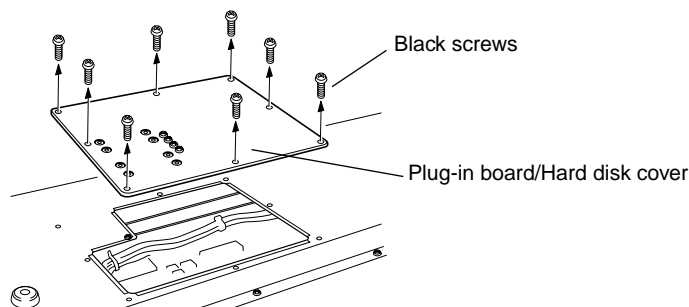

- ▶ **4** Remove the Plug-in board/Hard disk cover.

⚠ WARNING

- In order not to drop any screws inside the 9000Pro, keep the Plug-in Board and cover away from the 9000Pro in the following steps #5 - #7.

NOTE

- Keep the removed (8) screws in a safe place. They will be used when attaching the Plug-in board/Hard disk cover to the keyboard again.

Installing Optional Hardware

- ▶ **5** Turn over the Plug-in board/Hard disk cover.

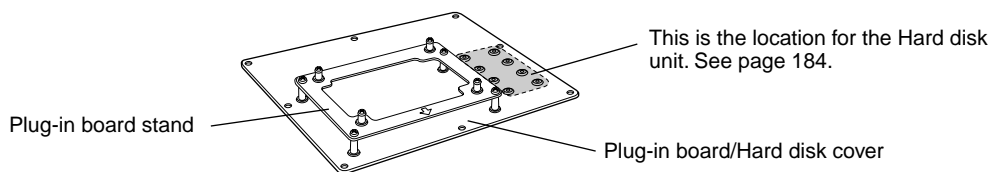

- ▶ **6** Attach the Plug-in Board to the Plug-in board stand. **First board**

- 6-[1]** Remove the four screws from the Plug-in stand with a Phillips screwdriver. Do not remove the other screws.

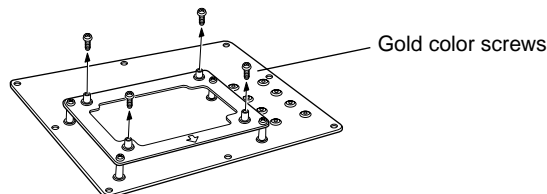

- 6-[2]** Attach the Plug-in board to the the Plug-in board stand using the four screws removed in the previous step (6-[1]).

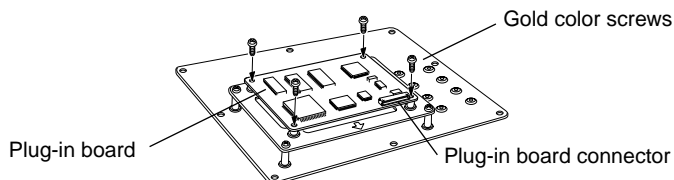

If you are installing a second board, go on to step #7 below. If you are installing only one board, go on to step #8.

- ▶ **7** As required, attach another Plug-in board to the Plug-in board stand. **Second board**

- 7-[1]** Remove the four screws from the Plug-in stand and remove the Plug-in stand from the cover. Do not remove the other screws.

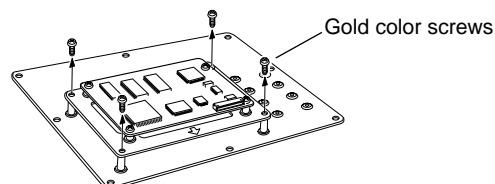

- 7-[2]** Attach another Plug-in board by turning over the Plug-in board stand and using the same operations in steps 6-[1] and 6-[2].

When turning over the board, let it rest on a soft surface.

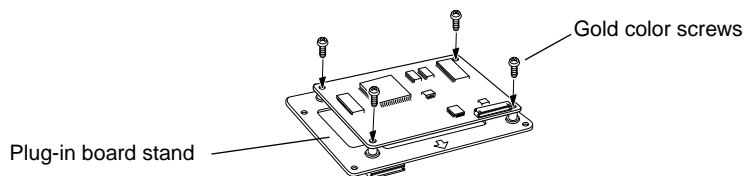

- 7-[3]** Attach the Plug-in board stand to the Plug-in board/Hard disk cover with the four screws removed in step 7-[1].

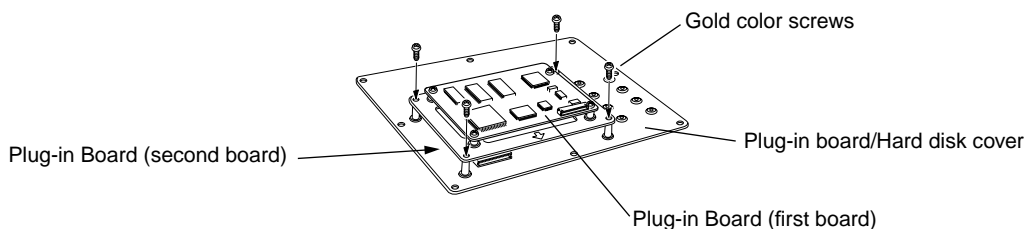

▶ **8 Unfasten the cable inside the 9000Pro as shown in the following illustration.**

There are three cables available for installation. The two smaller cables are used for the Plug-in Boards; the larger cable is for the hard disk.

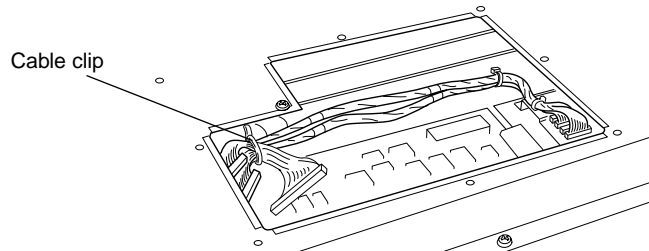

▶ **9 Carefully plug the cable connector into the Plug-in board connector until the two notches on the cable connector lock into the sockets on the board as shown in the illustration.**

The two cables can be used interchangeably. The cable that is used determines the slot number used by the 9000Pro. The cable with the single orange cord corresponds to Slot 1. The cable with the yellow cord corresponds to Slot 2. Keep in mind that the slot number is determined by the cable, not the actual installation position of the board.

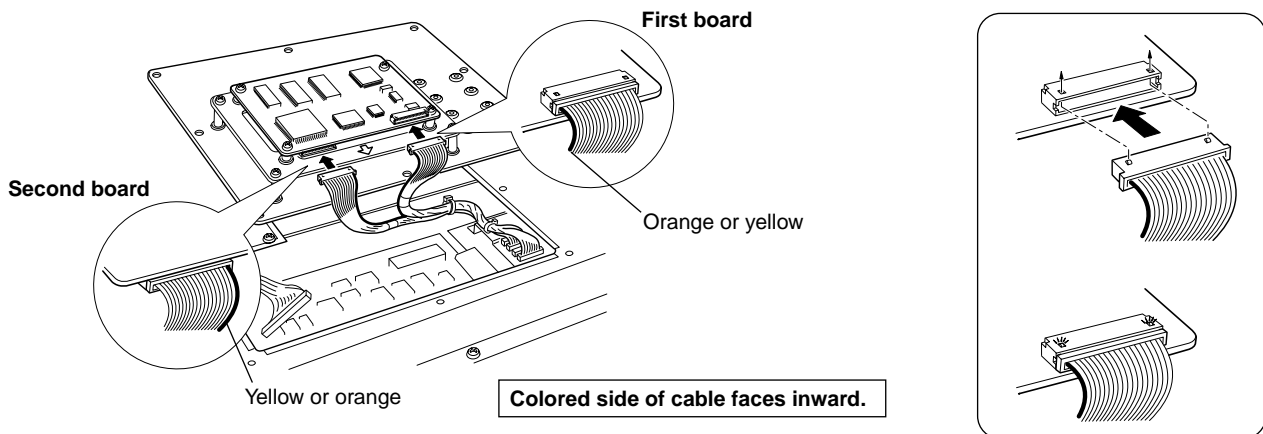

▶ **10 Attach the Plug-in board/Hard disk cover to the 9000Pro.**

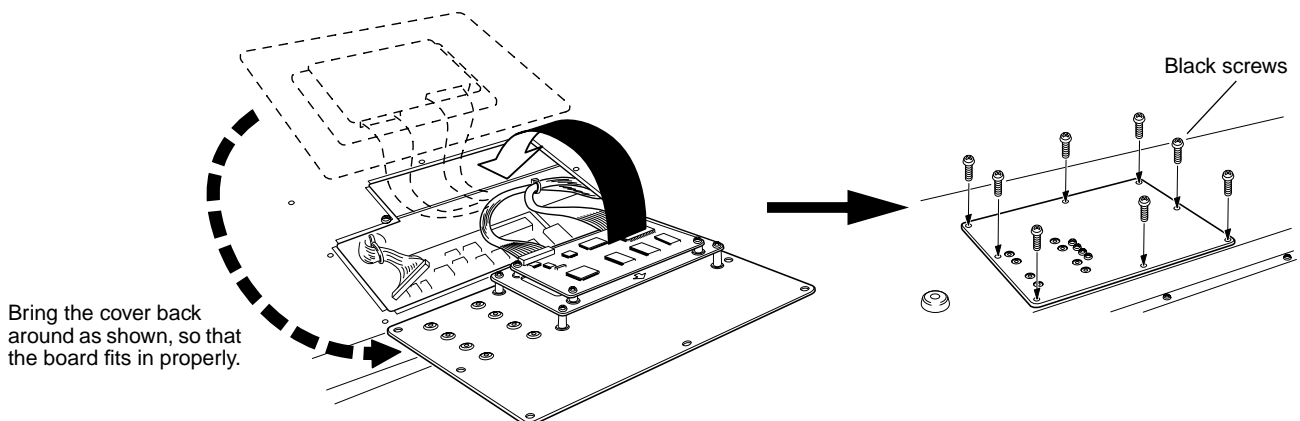

▶ **11 Check that the installed Plug-in board is functioning properly.**

Turn on the power.

- A message appears indicating that the installed Plug-in Board is being initialized. The main display then appears, indicating that the board has been successfully installed.
- If an error message appears, the 9000Pro freezes after a while, indicating that the installation was not successful. If this happens, turn off the power and carefully go through the installation procedure again.
- If you cannot select a Plug-in Voice even though no error message appears, the board has probably not been connected. If this happens, turn off the power and make sure that the Plug-in Board is securely connected.

Optional Hard Disk Installation

The hard disk used must be a 2.5-inch IDE-compatible; however, not all such drives may be installable.

⚠ CAUTION

- When inserting hard disk unit and connecting cables, make sure that you check that they are inserted and connected properly. Improperly inserted hard disk unit and cables may cause faulty contacts and an electrical short circuit which may cause damage or result in a malfunction.
- After mounting the hard disk unit, be sure to tighten the screws as directed so it is completely stable and does not move in any way.

NOTE

- Hard disk drives of a maximum 8 GB capacity can be formatted; however, the maximum partition size is 2 GB. For example, an 8 GB hard disk drive would have to be formatted into four separate 2 GB partitions.
- Hard disk drives of a capacity greater than 8 GB can be installed; however, the 9000Pro is capable of formatting only up to a maximum 8 GB on the drive.
- Hard disk drives wider than 12.7 mm cannot be installed to the 9000Pro.

For information on the hard disk recommendations, ask your nearest Yamaha representative or an authorized distributor listed at the end of this owner's manual. Install a hard disk at your own risk. Yamaha will not be held responsible for any damage or injury resulting from improper installation or the use of a hard disk other than one of the types recommended by Yamaha.

- ▶ **1-4** Use the same operation as in "Optional Plug-in Board Installation" (page 181).

⚠ WARNING

- In order not to drop any screws inside the 9000Pro, keep the Plug-in Board and cover away from the 9000Pro in the following steps #5 - #8. If the Plug-in Board has been installed, pull out the cable connector from the Plug-in Board connector.

- ▶ **5** Remove the four screws from the Plug-in board/Hard disk cover.
- ▶ **6** Turn over the Plug-in board/Hard disk cover.

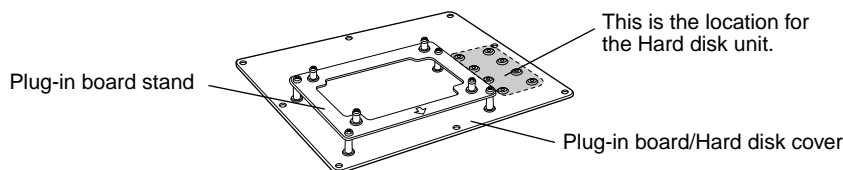
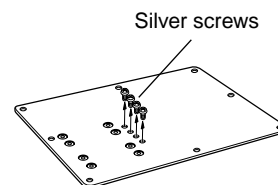

If a Plug-in Board (or boards) is installed, make sure to disconnect the Plug-in Board connector(s) before continuing.

- ▶ **7** Hold the hard disk unit in place with your hand as shown below. Make sure that the socket end of the unit faces toward you as shown.

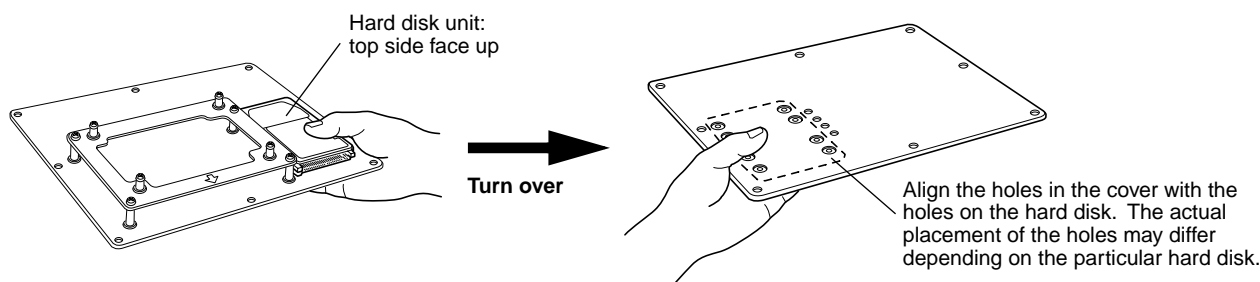

- ▶ **8** Attach the hard disk unit to the Plug-in board/Hard disk cover using the four screws removed in step 5.

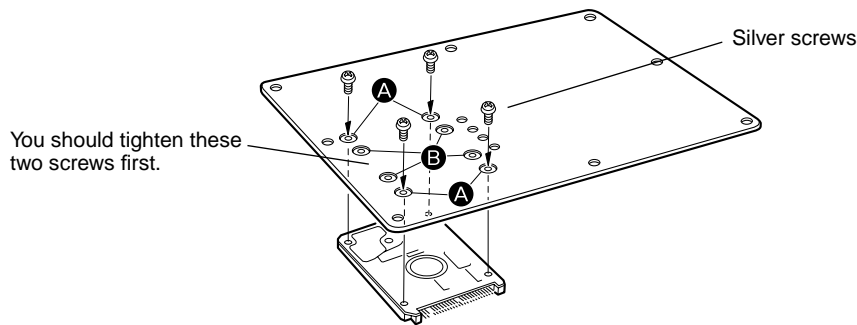

NOTE

- Depending on the type of hard disk drive you plan to install, select holes (A) or holes (B) to attach the hard disk drive.
- * Holes (A) are used in this illustration.

- ▶ **9** Turn the cover over again, and attach the cable connector as shown.

Undo the cable clip (to the large cable), and plug it into the hard disk socket.

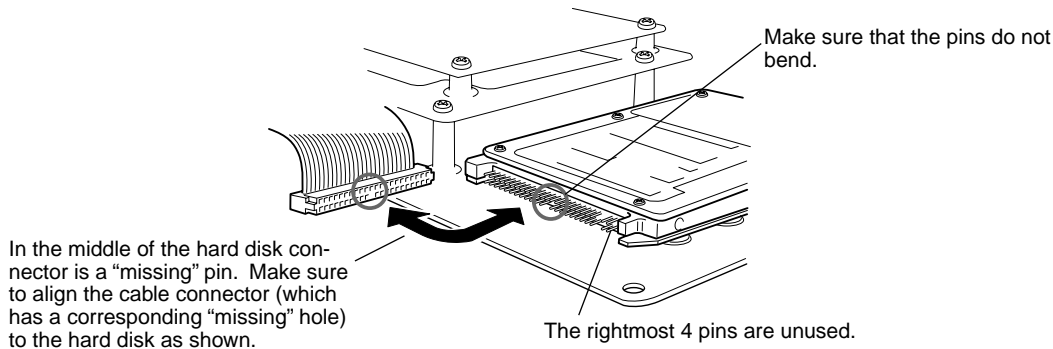

Re-attach the Plug-in Board cable(s) if necessary.

- ▶ **10** Attach the Plug-in board/Hard disk cover to the 9000Pro (page 183).
- ▶ **11** Check that the installed hard disk is functioning properly. Turn on the power, go to the DISK display, and execute the Format Hard Disk function (page 156). If the format is completed with no trouble, the hard disk is OK.

Optional SIMM Installation

The SIMMs used must meet the following minimum specifications, but this does not guarantee that they will work properly with the 9000Pro. Make sure to install the SIMMs in pairs only; also make sure that both modules of the pair are of the same type and memory capacity, and are from the same manufacturer. Consult with your nearest Yamaha representative or an authorized distributor listed at the end of this manual before purchasing SIMMs for the 9000Pro.

- 16-bit bus compatibility or compliance with JEDEC standards (SIMMs which are only compatible with 32-bit buses can not be used)
- 70 nanoseconds or faster access time (note: 60 nanosecond SIMMs are faster than 70 nanosecond SIMMs).
- No more than 18 memory chips on each SIMM module.
- SIMM modules must be no more than 25.4 mm in height and the thickness of the SIMM should not exceed 8mm on either side when measured from the center of the SIMM. See below.
- SIMMs with parity and EDO DRAM modules can also be used.
- Use only SIMMs of 4-, 8-, 16-, or 32-megabyte capacity.
- Install SIMM memory at your own risk. Yamaha will not be held responsible for any damage or injury resulting from improper installation.

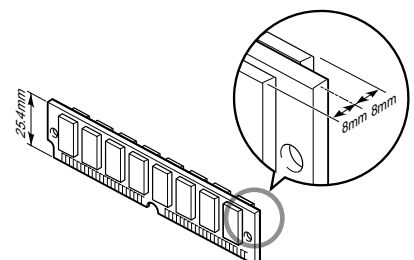

Installing Optional Hardware

- ▶ **1-2** Use the same operation as in "Optional Plug-in Board Installation" (page 181).
- ▶ **3** Move to a position facing the rear panel of the keyboard, and remove the six screws from the SIMM cover with a Phillips screwdriver. Do not remove the other screws.
- ▶ **4** Remove the SIMM cover.
- ▶ **5** Insert the SIMMs in the SIMM slots as described below.

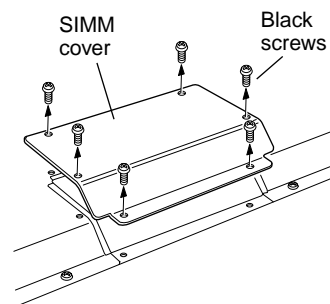

First SIMM

- 5-[1]** Make sure the orientation is correct. Make sure that the cutout on the SIMM module is aligned with the protruding "key" on the connector slot.

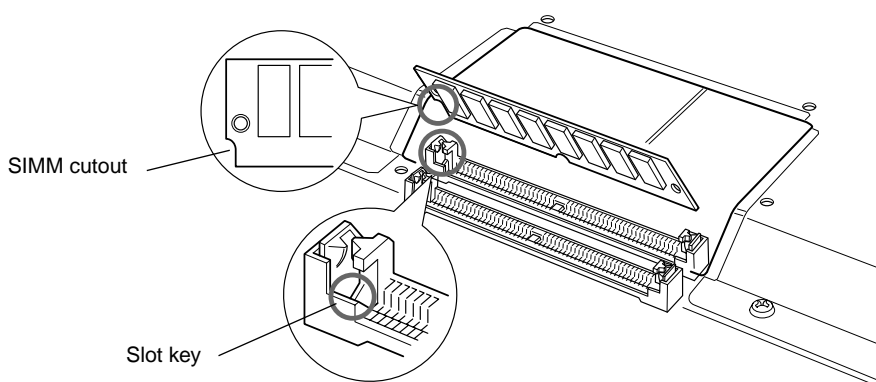

CAUTION

- Do not install the SIMM backwards.

- 5-[2]** Install the first SIMM in the rear slot (the slot closest to the 9000Pro rear panel), inserting it at an angle as shown in the illustration. Make sure that the parts at locations A, B, and C are properly aligned.

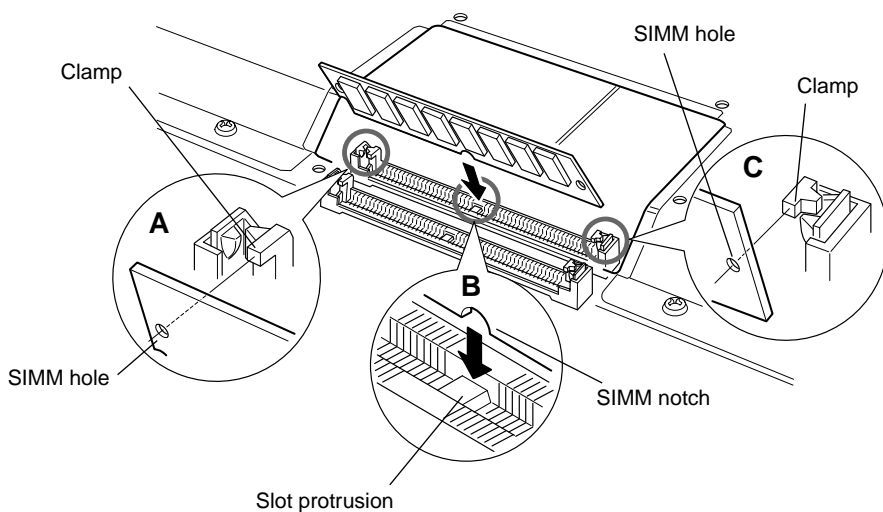

CAUTION

- Make sure that the entire length of the SIMM is evenly inserted.

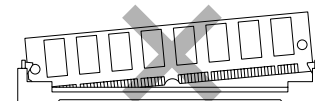

5-[3] Holding both edges of the SIMM module, raise it to the vertical position until it firmly locks in place with the left and right clamps.

CAUTION

- Make sure that the entire length of the SIMM is evenly inserted.

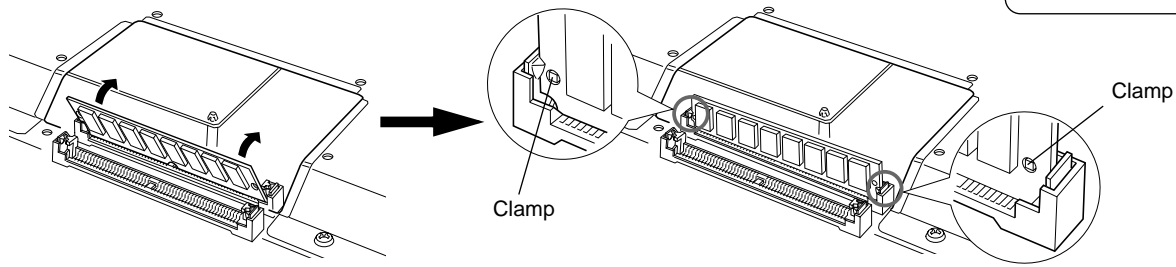

Second SIMM

5-[4] After confirming the orientation, insert the second SIMM into the front slot (the slot closest to the 9000Pro keyboard), and raise it to the vertical position in the same way as the first SIMM.

▶ **6** Replace the SIMM cover and attach it to the 9000Pro with the six screws.

▶ **7** Check that the installed SIMMs are functioning properly.

Set the 9000Pro right-side up, and connect the power cord to the rear-panel AC INLET jack and an AC outlet.

Turn on the power, go to the SAMPLING display (page 41), and check that the REMAIN TIME value matches the amount of installed memory, as follows:

• 4MB x 2	106.9s
• 8MB x 2	202.1s
• 16MB x 2	392.3s
• 32MB x 2	772.7s
• No SIMMS	11.8s

(These values apply when there is no data in the wave memory.)

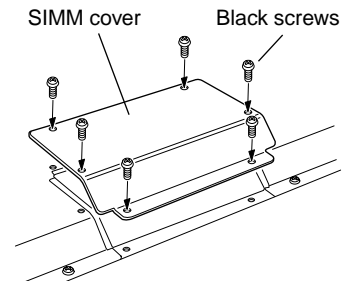

NOTE

- Although the wave memory of the 9000Pro can be expanded to 65 megabytes, the maximum size of a single sample recording is 32 mega bytes (380 sec.).

■ Removing SIMMs

SIMM modules can be removed after opening the clamps at both ends of the connector slot.

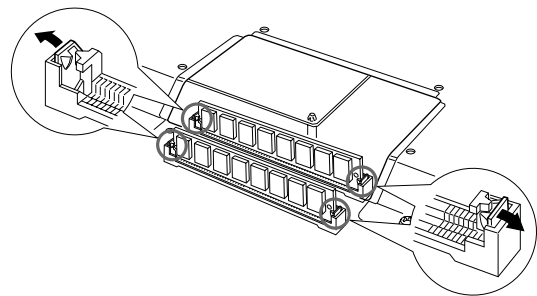

Troubleshooting

PROBLEM	POSSIBLE CAUSE/SOLUTION
<ul style="list-style-type: none"> When using a mobile phone, noise is produced. 	<p>Using a mobile phone in close proximity to the 9000Pro may produce interference. To prevent this, turn off the mobile phone or use it further away from the 9000Pro.</p>
<ul style="list-style-type: none"> No sound results. 	<ul style="list-style-type: none"> The R1/R2/R3/L voice volume (Main Mixer) settings could be set too low. Make sure the voice volumes are set at appropriate levels (page 25). The Local Control function could be turned off. Make sure Local Control is turned on (page 175). The [MASTER VOLUME] controls or foot volume are turned all the way down. Set the [MASTER VOLUME] controls and foot volume to a reasonable listening level. Are the desired parts turned on? ([PART ON/OFF] button — page 57) A pair of headphones is plugged into the PHONES jack. Unplug the headphones. A plug is inserted in the LOOP SEND jacks. Unplug the LOOP SEND jacks. Is the Footswitch connected to the FOOT VOLUME connector? The [FADE IN/OUT] button is on and has reached the end of its duration, muting the sound. Press the [FADE IN/OUT] button so that its indicator goes out. Check whether the external speaker is connected properly.
<ul style="list-style-type: none"> Not all simultaneously-played notes sound. Auto Accompaniment seems to “skip” when the keyboard is played. 	<p>You are probably exceeding the maximum polyphony of the 9000Pro. The 9000Pro can play up to 126 notes at the same time — including voice R2, voice R3, voice L, auto accompaniment, song, and multi pad notes. When the maximum polyphony is exceeded, the earliest played notes will stop sounding, letting the latest played notes sound. This is referred to as “last-note priority.”</p>
<ul style="list-style-type: none"> The accompaniment or song does not play back even when pressing the [START/STOP] button. The Multi Pads do not play back, even when one of the MULTI PAD buttons is pressed. 	<p>The MIDI Clock may be set to “EXTERNAL.” Make sure it is set to “INTERNAL” (page 175).</p>
<ul style="list-style-type: none"> The auto accompaniment does not start, even when Synchro Start is in standby condition and a key is pressed. 	<p>You may be trying to start accompaniment by playing a key in the right-hand range of the keyboard. To start the accompaniment with Synchro Start, make sure to play a key in the left-hand (accompaniment) range of the keyboard.</p>
<ul style="list-style-type: none"> Certain notes sound at the wrong pitch. 	<p>Make sure that the scale tuning value for those notes is set to “0” (page 158).</p>
<ul style="list-style-type: none"> Auto accompaniment chords are recognized regardless of the split point or where chords are played on the keyboard. 	<p>Check whether the fingering mode is set to “Full Keyboard” or not. If the Full Keyboard fingering mode is selected, chords are recognized over the entire range of the keyboard, irrespective of the split point setting.</p>
<ul style="list-style-type: none"> The Harmony function does not operate. 	<ul style="list-style-type: none"> Harmony cannot be turned on when the Full Keyboard fingering mode is selected. Select an appropriate fingering mode.

PROBLEM	POSSIBLE CAUSE/SOLUTION
<ul style="list-style-type: none"> MIDI data is not transmitted or received via the MIDI A terminals, even when MIDI cables are connected properly. 	<p>The MIDI terminals can only be used when the HOST SELECT switch is set to "MIDI." All other settings ("Mac," "PC-1" and "PC-2") are for direct transmission/ reception with a computer.</p>
<ul style="list-style-type: none"> If you experience distorted or out-of-tune sound from the Vocal Harmony feature, your vocal microphone may be picking up extraneous sounds (other than your voice) — the Auto Accompaniment sound from the 9000Pro, for example. In particular, bass sounds can cause mistracking of the Vocal Harmony feature. 	<p>The solution to this problem is to ensure that as little extraneous sound as possible is picked up by your vocal microphone:</p> <ul style="list-style-type: none"> Sing as closely to the microphone as possible. Use a directional microphone. Turn down the MASTER VOLUME, ACMP volume, or SONG volume control. Separate the microphone from the external speakers as much as possible. Cut the Low band via the 3 Band EQ function in the MIC SETUP display (page 82).
<ul style="list-style-type: none"> When a voice is changed, the previously selected effect is changed. 	<p>This is normal, each voice has its own suitable preset values which are automatically recalled when the corresponding Voice Set parameters are turned on (page 163).</p>
<ul style="list-style-type: none"> There is a slight difference in sound quality between notes played on the keyboard. Some voices have a looping sound. Some noise or vibrato is noticeable at higher pitches, depending upon the voice. 	<p>This is normal and is a result of the 9000Pro's sampling system.</p>
<ul style="list-style-type: none"> Some voices will jump an octave in pitch when played in the upper or lower registers. 	<p>Some voices have a pitch limit which, when reached, causes this type of pitch shift. This is normal.</p>
<ul style="list-style-type: none"> The auto-accompaniment chord does not change even when a different chord is played or the chord is not recognized. 	<ul style="list-style-type: none"> Are you sure you're playing on the left-hand section of the keyboard? You may be using single-finger type fingering in the fingered mode, or vice versa. Use the correct type of chord fingering for the selected auto-accompaniment fingering mode.
<ul style="list-style-type: none"> The displayed disk free area value does not coincide with the actual value. 	<p>The displayed value is an approximate value.</p>
<ul style="list-style-type: none"> Disk save operations — particularly when saving wave data to floppy disk — take a long time. 	<p>This is normal. It takes approximately 8 minutes to save 1 megabyte of data to a floppy disk.</p>
<ul style="list-style-type: none"> Appropriate harmony notes are not produced by the Vocal Harmony feature. 	<p>Make sure you are using the appropriate method to specify the harmony notes for the current Vocal Harmony mode. See page 83.</p>
<ul style="list-style-type: none"> The voice produces excessive noise. 	<p>Certain voices may produce noise, depending on the Harmonic Content and/or Brightness settings of the Mixing Console Filter. This is unavoidable due to the sound generation and processing system of the 9000Pro. To avoid noise, change the above mentioned settings.</p>
<ul style="list-style-type: none"> The sound is distorted or noisy. 	<ul style="list-style-type: none"> The MASTER VOLUME control may be turned up too high. This may be caused by the effects. Try cancelling all unnecessary effects, especially distortion-type effects. Some filter resonance settings in the Custom Voice Creator display can result in distorted sound. Is the gain of the Low band set too high in the Master Equalizer display (Mixing Console – page 147) ? If this applies to the "Sampled" voice, you may have recorded the sample(s) at too high a level. (See page 84.)
<ul style="list-style-type: none"> A strange "flanging" or "doubling" sound occurs. The sound is slightly different each time the keys are played. 	<ul style="list-style-type: none"> Are the R1 and R2 parts set to "ON" and both parts set to play the same voice? If you are routing the MIDI OUT on the 9000Pro to a sequencer and back to the MIDI IN, you may want to set Local Control (page 175) to "off" to avoid MIDI "feedback."
<ul style="list-style-type: none"> When a disk is inserted into the disk drive, the [DISK IN USE] lamp automatically lights and the data starts loading automatically, even though no disk functions have been executed. 	<p>This is normal and no cause for concern if "FD CACHE" (page 166) has been set to "ON." If you do not need the data loaded to cache memory, you can eject the floppy disk. You can also operate other functions from the panel without disturbing the automatic cache loading process.</p>

- A**
- AC1 103
 - Accompaniment, starting 20
 - Accompaniment, volume 25
 - After Touch 60, 162
 - All 56, 151
 - All Clear 68
 - Arabic tuning 158
 - Assignable Control 103
 - Attack 63, 93
 - Auto accompaniment 20, 70
 - Auto Exit time 167
 - Auto Load 64, 69, 100, 166
 - Auto Trigger Level 84
 - AUX IN/LOOP RETURN jacks 12
- B**
- Backup 55, 154
 - Bank 28, 34, 77, 141
 - Bank View 28, 77
 - Basic Operation 44
 - Basic Procedure 62, 66, 74, 81, 82, 86, 92, 101, 111, 128, 141, 144, 150, 158, 174
 - Bass Chord Hold 21
 - Bass Hold 160
 - Beat indicator 45
 - Board Custom Voice 64, 100
 - Board Custom Voice Backup 64, 100, 108
 - Board Preset Voice 64, 100
 - Board Voice 43, 64, 100, 102
 - Break 22
 - Brightness 145
- C**
- Category 26, 56, 74
 - Check Disk 157
 - Chord Detect 177
 - Chord Match 77, 142
 - Chord note 142
 - Chord Step 122
 - Chordal 81, 83
 - Chorus 146
 - Clear 87, 142
 - Clock 175
 - Complete Save 68
 - Compressor 82, 147
 - Computer connections 172
 - Configuration 166
 - Convert 155
 - Copy 75, 142, 154
 - Custom voice 92
 - Custom voice creator 92
- D**
- Decay 93
 - Defragment 75
 - Delay 81, 93
 - Delete 68, 75, 113, 155
 - Demonstration playback 56
 - Detune 81
 - Device 150
 - Dimmer 15
 - Direct Access 48
 - Direct Access chart 49
 - Directory 78, 151
 - Disk 54, 150
 - Disk Direct 25
 - Disk/SCSI operations 150
 - Display 44
 - Display messages 45
 - DOC 7, 171
 - DSP 35
 - DSP (1) 147
 - DSP (2) 147
 - DSP (3) 146, 147
 - DSP (4) 35, 146, 147
 - DSP (5) 35, 146, 147
 - DSP (6) 35, 146, 147
 - DSP (7) 35, 146, 147
 - DSP (8) 146, 147
 - DSP (9) 147
 - Duet 164
 - Dynamics 131
- E**
- Easy Edit 93, 130, 131
 - Edit directory 156
 - Effect block 146
 - Effect depth 145
 - Effect parameter 222
 - Effect signal flow 147
 - Effect type list 220
 - EG 93
 - Element 94
 - End Key 86
 - End point 89
 - Ending 22, 160
 - EQ 147
 - Equal Temperament 158
 - Event Filter 122, 125
 - Event List 120, 125
 - Exit 44
 - Extract 89
- F**
- Fade in/out 23, 72, 160
 - Fast Forward 79
 - FD Cache 166
 - Fill In 22
 - Filter 93, 145
 - Fingered 70
 - Fingering 70
 - Fixed Pitch 86
 - Flash ROM 54
 - Flash style 55
 - Floppy Disk 5, 150
 - Foot controller 13, 159
 - FOOT PEDAL SWITCH jacks 13
 - FOOT PEDAL VOLUME jack 13
 - Footswitch 13, 160
 - Format 156
 - Forward 79
 - Freeze 28, 163
 - Frequency 82, 93, 145, 147
 - Full Edit 94, 132, 134, 140
 - Full keyboard 70
 - Functions 158
- G**
- GM 6, 171
 - Groove 131
- H**
- Hard disk installation 184
 - Harmonic Content 145
 - Harmony/echo 35, 160, 164
 - Headphone 10
 - Highest key 136
 - HOST SELECT switch 13, 169
- I**
- Initial touch 60, 162
 - Intro 22, 160
- K**
- Keyboard drum assignments 200
 - Keyboard percussion 58
 - Keyword 27
- L**
- Lamp 12, 15
 - Language 45
 - LCD CONTRAST control 44
 - LCD display 44
 - Left 18, 57
 - Left hold 61
 - Line out 148
 - Load 54, 66, 74, 152
 - Local control 175
 - Loop 89, 126
 - LOOP SEND jacks 12
 - Lyrics 79
- M**
- Main Mixer 25, 31
 - Main variation 22, 160
 - Master EQ 147
 - Master tune 158
 - Master volume 14
 - Measure 112, 113
 - Message Switch 175
 - Metronome 21, 37, 39, 166
 - MFC10 178
 - MIC/LINE IN jack 13
 - Microphone 13, 32, 80, 83
 - MIDI 168
 - MIDI Data Format 228
 - MIDI Implementation Chart 244
 - MIDI templates 174
 - MIDI terminals 13
 - Mixing console 144
 - Mode 83

- Modulation59, 161
 MODULATION wheel59, 161
 Multi151
 Multi Assign164
 Multi Finger70
 Multi Pad34, 77, 141
 Multi Pad Creator141
 Multi Pad Recording142
 Multi Part Plug-in Board65
 Multi Track record38, 110
 Music Database26, 76
 Music stand10
- N**
- Name entry46
 Native Part Parameter104
 Native System Parameter105
 Noise Gate82
 Normalize90
 Note Limit95, 137
 NTR127, 136
 NTSC/PAL165
 NTT127, 136
- O**
- Octave18, 61, 145
 Offset Volume105
 On Bass70
 One Touch Setting24, 73
 Options180
 Organ Flutes19, 62
 Overdub126
- P**
- Packing list6
 Panel logos6
 Panpot145
 Parameter chart214
 Parameter lock166, 214
 Part on/off16, 17, 18, 24, 31
 Parts57
 Password156
 Paste121
 PC keyboard12, 46, 167
 PHONES jack13
 Pitch bend range145
 PITCH BEND wheel59
 Play mode56
 Playback21, 30, 32, 33, 34, 78
 Plug-in Board42, 64, 100
 Plug-in Board installation181
 Plug-in Custom Voice64, 100
 Plug-in Manager64, 66, 100
 Plug-in Setting69
 Plug-in Voice43, 64, 100
 Poly counter166
 Poly Expansion69
 Poly/mono35, 60
 Port173
 Portamento145, 160
 POWER switch14
- Pre effect87
 Precautions4
 Preset style55
 Property74, 150, 152
 PSR-800075, 155
 Punch-in112
- Q**
- Quantize114, 134
 Quick record36, 110
 Quick Save68
- R**
- RAM54
 Random56
 Receive176
 Receive Transpose175
 Registration bank28, 29, 163
 Registration memory28
 Rehearsal39
 Release93
 Rename75
 Repeat56, 77, 142
 Replace112
 Resampling88
 Resonance93
 Response10, 35, 60, 63
 Restore54, 154
 Reverb63, 145, 146, 165
 Reverse79
 Revoice130
 Right116, 57
 Right217, 57
 Right317, 57
 Root177
 RTR127, 137
- S**
- Sampling40, 84
 Save54, 55, 68, 75, 113, 153
 Scale Tune158
 SCSI13, 54, 150
 Search27, 79
 Setup54, 79, 214
 SIMM installation185
 SIMM removal187
 Single56, 151
 Single Finger70
 Single Part Plug-in Board65
 Slot 142, 69
 Slot 242, 69
 Slow/Fast35, 60, 160
 Soft160
 Song Creator36, 110
 Song playback30, 78
 Song recording36, 110
 Song setup79
 Sostenuato160
 Source Chord127, 135
 Source Root127, 135
 Specifications246
- Split point18, 20, 57, 70, 159
 Start Key86
 Start point89
 Step110, 116, 122, 140, 143
 Store19, 41, 54, 62, 74,
 81, 84, 92, 101, 128,
 141, 146, 147, 158
 Style20, 25, 55
 Style Assembly129
 Style File6, 7, 25, 127, 171
 Style list212
 Style Manager55, 74
 Sustain35, 60, 160
 Sustain mode161
 Swap75
 Synchronized start (Sync Start)20
 Synchronized stop (Sync Stop)73
- T**
- Talk setting80, 165
 Tap count166
 Tap tempo23, 72
 Tempo44, 72
 Thru Port173
 TO HOST13, 169, 173
 Touch10, 35, 60, 162
 Touch limit164
 Track24, 36, 38, 82,
 110, 112, 113, 129, 130
 Transmit175
 Transmit clock175
 Transpose61, 145, 175
 Troubleshooting188
 Tuning145, 158
- U**
- Ultra Quick Start79
 Utility166
- V**
- Velocity168, 169, 176
 Vibrato62, 63, 81, 93
 Video out13, 165
 Vocal harmony6, 32, 80
 Vocal harmony mode83
 Vocal harmony type33
 Vocoder81, 83
 Voice effects35, 60
 Voice list192
 Voice Set163
 Volume14, 24, 63, 83, 93, 130, 145
- W**
- Wave41, 84, 85, 87, 152
 Waveform85, 91, 95
- X**
- XF6, 171
 XG6, 171
 XGwork lite64, 100, 106
 XGworks64, 100, 106

Voice List/Stimmenliste/Liste des voix

Category Order	Voice Name	MSB#	LSB#	MIDI Program Change#
Piano				
1	Live! Grand	0	113	0
2	Grand Piano	0	112	0
3	BrightPiano	0	112	1
4	Harpsichord	0	112	6
5	GrandHarpsi	0	113	6
6	Honky Tonk	0	112	3
7	Rock Piano	0	114	2
8	Midi Grand	0	112	2
9	Oct Piano 1	0	113	3
10	Oct Piano 2	0	114	3
11	CP 80	0	113	2
E.Piano				
1	Galaxy EP	0	114	4
2	Stage EP	0	117	4
3	Polaris EP	0	115	4
4	Jazz Chorus	0	118	5
5	Hyper Tines	0	113	5
6	Cool! EP	0	119	4
7	Phase EP	0	120	4
8	New Tines	0	116	5
9	Funk EP	0	112	4
10	DX Modern	0	112	5
11	Vintage EP	0	116	4
12	Modern EP	0	115	5
13	Tremolo EP	0	113	4
14	Super DX	0	117	5
15	Clavi	0	112	7
16	Suitcase EP	0	118	4
17	Venus EP	0	114	5
18	Wah Clavi	0	113	7
Organ				
1	Cool! Organ	0	118	18
2	Rotor Organ	0	117	18
3	Rock Organ1	0	112	18
4	Dance Organ	0	113	17
5	Gospel Org	0	119	16
6	Cool! Jazz	0	117	16
7	Purple Org	0	114	18
8	Jazz Organ1	0	112	16
9	Rock Organ2	0	113	18
10	RotaryDrive	0	116	18
11	Full Rocker	0	115	18
12	Elec.Organ	0	118	17
13	DrawbarOrg	0	115	16
14	Click Organ	0	112	17
15	Stadium Org	0	118	16
16	Mellow Draw	0	115	17
17	Jazz Organ2	0	113	16
18	Bright Draw	0	116	16
19	60's Organ	0	116	17
20	Jazz Organ3	0	120	16
21	ChapelOrgn1	0	113	19
22	ChapelOrgn2	0	114	19

Category Order	Voice Name	MSB#	LSB#	MIDI Program Change#
23	ChapelOrgn3	0	115	19
24	TheatreOrg1	0	114	16
25	TheatreOrg2	0	114	17
26	Pipe Organ	0	112	19
27	Reed Organ	0	112	20
Accordion				
1	Musette	0	112	21
2	Tutti Accrd	0	113	21
3	Small Accrd	0	115	21
4	Accordion	0	116	21
5	Tango Accrd	0	112	23
6	Steirisch	0	117	21
7	Bandoneon	0	113	23
8	Soft Accrd	0	114	21
9	Modern Harp	0	113	22
10	Blues Harp	0	114	22
11	Harmonica	0	112	22
Guitar				
1	Live! Nylon	0	116	24
2	Cool! J.Gtr	0	115	26
3	Cool! E.Gtr	0	114	28
4	12StrGuitar	0	113	25
5	SolidGuitar	0	118	27
6	Vintage Amp	0	115	29
7	Aloha Gtr	0	118	26
8	Crunch Gtr	0	113	30
9	Carlos Gtr	0	119	26
10	60's Clean	0	117	27
11	Live! Class	0	115	24
12	Cool! JSolo	0	116	26
13	VintageOpen	0	123	27
14	Folk Guitar	0	112	25
15	Solid Chord	0	121	27
16	VintageMute	0	115	28
17	PedalSteel	0	115	27
18	Lead Guitar	0	114	29
19	SlideGuitar	0	125	27
20	Chorus Gtr	0	124	27
21	VintageTrem	0	120	27
22	Spanish Gtr	0	113	24
23	Octave Gtr	0	113	26
24	Deep Chorus	0	114	27
25	CampfireGtr	0	115	25
26	SmoothNylon	0	114	24
27	Tremolo Gtr	0	113	27
28	HawaiianGtr	0	114	26
29	Heavy Stack	0	114	30
30	BrightClean	0	116	27
31	Wah Guitar	0	122	27
32	Classic Gtr	0	112	24
33	DX JazzGtr	0	117	26
34	Distortion	0	112	30
35	Elec.12Str	0	119	27
36	FeedbackGtr	0	113	29

Category Order	Voice Name	MSB#	LSB#	MIDI Program Change#
37	Mandolin	0	114	25
38	CleanGuitar	0	112	27
39	MutedGuitar	0	112	28
40	Funk Guitar	0	113	28
41	Jazz Guitar	0	112	26
42	Overdrive	0	112	29
43	Finger Bass	0	112	33
44	UprightBass	0	113	32
45	Pick Bass	0	112	34
46	Jaco Bass	0	113	35
47	Slap Bass	0	112	36
48	Analog Bass	0	112	39
49	DX FunkBass	0	113	37
50	DrySynBass	0	116	39
51	Touch Bass	0	115	39
52	Hi Q Bass	0	113	38
53	Funk Bass	0	112	37
54	Aco.Bass	0	112	32
55	Fretless	0	112	35
56	Bass&Cymbal	0	114	32
57	Fusion Bass	0	113	36
58	Rave Bass	0	114	38
59	Dance Bass	0	113	39
60	Synth Bass	0	112	38
61	Snap Bass	0	114	39
62	Click Bass	0	115	38
Strings				
1	Live! Strs	0	117	49
2	Live! Arco	0	122	49
3	Live! Orch	0	116	49
4	Symphon.Str	0	114	48
5	OberStrings	0	113	51
6	Solo Violin	0	112	40
7	Orch. Brass	0	118	49
8	Orch. Flute	0	119	49
9	Orch. Fl.Br	0	120	49
10	Orch. Oboe	0	121	49
11	Strings	0	112	48
12	OrchStrings	0	113	48
13	Str.Quartet	0	114	49
14	ConcertoStr	0	115	48
15	Analog Strs	0	112	51
16	ChamberStrs	0	112	49
17	Bow Strings	0	116	48
18	SlowStrings	0	113	49
19	TremoloStrs	0	112	44
20	MarcatoStrs	0	115	49
21	Syn Strings	0	112	50
22	PizzStrings	0	112	45
23	Viola	0	112	41
24	Cello	0	112	42
25	Contrabass	0	112	43
26	Harp	0	112	46
27	Hackbrett	0	113	46

Category Order	Voice Name	MSB#	LSB#	MIDI Program Change#
28	Fiddle	0	112	110
29	Banjo	0	112	105
30	Sitar	0	112	104
31	Koto	0	112	107
32	Shamisen	0	112	106
33	Soft Violin	0	113	40
34	Orch.Hit	0	112	55
Trumpet				
1	Sweet Trump	0	115	56
2	Sweet Tromb	0	117	57
3	SoftTrumpet	0	114	56
4	JazzTrumpet	0	116	56
5	SweetMuteTp	0	114	59
6	SoloTrumpet	0	112	56
7	Air Trumpet	0	117	56
8	SweetFlugel	0	118	56
9	Trombone	0	116	57
10	BaritonHorn	0	113	58
11	Solo Tromb	0	112	57
12	Soft Tromb	0	115	57
13	MellowTromb	0	114	57
14	French Horn	0	112	60
15	Muted Trump	0	112	59
16	Bariton Hit	0	114	58
17	Alp Bass	0	113	33
18	Flugel Horn	0	113	56
19	Tuba	0	112	58
Brass				
1	Live! Horns	0	118	62
2	Live! Brass	0	117	62
3	Live! OctBr	0	116	62
4	MellowBrass	0	116	61
5	Sforzando	0	125	61
6	MoonLight	0	115	71
7	MillerNight	0	119	66
8	Saxy Mood	0	120	66
9	Jump Brass	0	113	62
10	Big Brass	0	121	61
11	BrasSection	0	112	61
12	BrightBrass	0	120	61
13	Soft Brass	0	123	61
14	Full Horns	0	114	61
15	Brass Combo	0	115	66
16	SmoothTromb	0	118	57
17	High Brass	0	115	61
18	Ober Brass	0	113	63
19	Trumpet Ens	0	122	61
20	MellowHorns	0	119	61
21	BigBandBrs	0	113	61
22	Pop Brass	0	118	61
23	Brass Hit	0	126	61
24	Step Brass	0	124	61
25	Analog Brs	0	112	63
26	BallroomBrs	0	113	59

Voice List/Stimmenliste/Liste des voix

Category Order	Voice Name	MSB#	LSB#	MIDI Program Change#
27	Trb.Section	0	113	57
28	Small Brass	0	117	61
29	Soft Analog	0	114	63
30	FunkyAnalog	0	115	62
31	TechnoBrass	0	114	62
32	Synth Brass	0	112	62
Saxophone				
1	Sweet Tenor	0	117	66
2	Sweet Alto	0	114	65
3	Sweet Sprno	0	113	64
4	Sweet Clari	0	114	71
5	Growl Sax	0	118	66
6	BreathTenor	0	114	66
7	BreathyAlto	0	113	65
8	Soprano Sax	0	112	64
9	MelClarinet	0	113	71
10	Sax Section	0	116	66
11	WoodwindEns	0	113	66
12	Alto Sax	0	112	65
13	Tenor Sax	0	112	66
14	BaritoneSax	0	112	67
15	Rock Bari	0	113	67
16	Oboe	0	112	68
17	EnglishHorn	0	112	69
18	Bassoon	0	112	70
19	Clarinet	0	112	71
Flute				
1	Sweet Flute	0	114	73
2	Sweet Pan	0	113	75
3	Class.Flute	0	115	73
4	Pan Flute	0	113	73
5	Flute	0	112	73
6	Piccolo	0	112	72
7	EthnicFlute	0	112	75
8	Shakuhachi	0	112	77
9	Whistle	0	112	78
10	Recorder	0	112	74
11	Ocarina	0	112	79
12	Bagpipe	0	112	109
Choir & Pad				
1	Live!Gospel	0	116	52
2	Live! Humm	0	118	52
3	Hah Choir	0	114	52
4	SweetHeaven	0	118	88
5	DreamHeaven	0	121	88
6	Live! Vocal	0	114	53
7	Bah Choir	0	121	53
8	Live! Doo	0	117	53
9	Live! Bah	0	118	53
10	Live! Dao	0	119	53
11	Live! Mmh	0	117	52
12	Gothic Vox	0	113	53
13	Huh Choir	0	119	52
14	Bell Heaven	0	119	88

Category Order	Voice Name	MSB#	LSB#	MIDI Program Change#
15	Pan Heaven	0	120	88
16	DooBa Scats	0	115	53
17	Daa Choir	0	120	53
18	Doo Choir	0	122	53
19	Doom Choir	0	120	52
20	Live! Doom	0	116	53
21	Choir	0	112	52
22	Air Choir	0	112	54
23	Vocal Ensbl	0	113	52
24	Insomnia	0	113	94
25	Cyber Pad	0	113	99
26	Vox Humana	0	112	53
27	Voices	0	113	54
28	Uuh Choir	0	115	52
29	Wave 2001	0	112	95
30	Neo WarmPad	0	115	89
31	Atmosphere	0	112	99
32	Xenon Pad	0	112	91
33	Skydiver	0	112	101
34	Far East	0	112	97
35	Template	0	114	95
36	Equinox	0	112	94
37	Glass Pad	0	114	93
38	Fantasia	0	112	88
39	DX Pad	0	112	92
40	Symbiont	0	113	88
41	Stargate	0	114	88
42	Area 51	0	112	89
43	Dark Moon	0	113	89
44	Ionosphere	0	115	94
45	Golden Age	0	115	88
46	Solaris	0	114	94
47	Time Travel	0	116	88
48	Millenium	0	117	88
49	Transform	0	113	95
50	Dunes	0	114	89
51	Pro Heaven	0	122	88
52	Sunbeam	0	123	88
Synthesizer				
1	Oxygen	0	122	81
2	Matrix	0	123	81
3	Wire Lead	0	120	81
4	Hip Lead	0	113	80
5	Hop Lead	0	117	80
6	Square Lead	0	112	80
7	Saw.Lead	0	112	81
8	Fire Wire	0	116	81
9	Analogon	0	115	81
10	Funky Lead	0	121	81
11	Paraglide	0	114	84
12	Robolead	0	124	81
13	Fargo	0	119	81
14	Portatone	0	112	84
15	Blaster	0	114	81

Category Order	Voice Name	MSB#	LSB#	MIDI Program Change#
16	Big Lead	0	113	81
17	Warp	0	117	81
18	Adrenaline	0	113	84
19	Synchronize	0	112	96
20	Tiny Lead	0	118	80
21	Stardust	0	112	98
22	Aero Lead	0	112	83
23	Mini Lead	0	114	80
24	Synth Flute	0	119	80
25	Sub Aqua	0	118	81
26	Impact	0	113	87
27	Sun Bell	0	113	98
28	Under Heim	0	112	87
29	Rhythmic	0	113	96
30	Hi Bias	0	116	80
31	Vinylead	0	115	80
32	Skyline	0	115	84
33	Clockwork	0	114	96
Percussion				
1	Vibraphone	0	112	11
2	Jazz Vibes	0	113	11
3	Marimba	0	112	12
4	Xylophone	0	112	13
5	Steel Drums	0	112	114
6	Celesta	0	112	8
7	Glocken	0	112	9
8	Music Box	0	112	10
9	TubularBell	0	112	14
10	Kalimba	0	112	108
11	Dulcimer	0	112	15
12	Timpani	0	112	47
13	Live!StdKit	127	0	80
14	Live!FunkKt	127	0	81
15	Live!Brush	127	0	82
16	Live!Std+P	127	0	83
17	Live!Funk+P	127	0	84
18	Live!Brsh+P	127	0	85
19	Std.Kit1	127	0	0
20	Std.Kit2	127	0	1
21	Hit Kit	127	0	4
22	Room Kit	127	0	8
23	Rock Kit	127	0	16
24	Electro Kit	127	0	24
25	Analog Kit	127	0	25
26	Dance Kit	127	0	27
27	Jazz Kit	127	0	32
28	Brush Kit	127	0	40
29	SymphonyKit	127	0	48
30	Arabic Kit	126	0	35
31	Live!Cuban	126	0	40
32	Live!PopLtn	126	0	43
33	SFX Kit1	126	0	0
34	SFX Kit2	126	0	1
35	StyleLvStd	127	0	123

Category Order	Voice Name	MSB#	LSB#	MIDI Program Change#
36	StyleLvFunk	127	0	124
37	StyLvStd+P	127	0	125
38	StyLvFunk+P	127	0	126
XG				
1	GrandPno	0	0	0
2	GrndPnoK	0	1	0
3	MelloGrP	0	18	0
4	PianoStr	0	40	0
5	Dream	0	41	0
6	BritePno	0	0	1
7	BritPnoK	0	1	1
8	E.Grand	0	0	2
9	EIGrPnoK	0	1	2
10	Det.CP80	0	32	2
11	EIGrPno1	0	40	2
12	EIGrPno2	0	41	2
13	HnkyTonk	0	0	3
14	HnkyTnkK	0	1	3
15	E.Piano1	0	0	4
16	EI.Pno1K	0	1	4
17	MelloEP1	0	18	4
18	Chor.EP1	0	32	4
19	HardEI.P	0	40	4
20	VX EI.P1	0	45	4
21	60sEI.P	0	64	4
22	E.Piano2	0	0	5
23	EI.Pno2K	0	1	5
24	Chor.EP2	0	32	5
25	DX Hard	0	33	5
26	DXLegend	0	34	5
27	DX Phase	0	40	5
28	DX+Analg	0	41	5
29	DXKotoEP	0	42	5
30	VX EI.P2	0	45	5
31	Harpsi.	0	0	6
32	Harpsi.K	0	1	6
33	Harpsi.2	0	25	6
34	Harpsi.3	0	35	6
35	Clavi.	0	0	7
36	Clavi. K	0	1	7
37	ClaviWah	0	27	7
38	PulseClv	0	64	7
39	PierceCl	0	65	7
40	Celesta	0	0	8
41	Glocken	0	0	9
42	MusicBox	0	0	10
43	Orgel	0	64	10
44	Vibes	0	0	11
45	VibesK	0	1	11
46	HardVibe	0	45	11
47	Marimba	0	0	12
48	MarimbaK	0	1	12
49	SineMrmb	0	64	12
50	Balafon2	0	97	12

Voice List/Stimmenliste/Liste des voix

Category Order	Voice Name	MSB#	LSB#	MIDI Program Change#
51	Log Drum	0	98	12
52	Xylophon	0	0	13
53	TubulBel	0	0	14
54	ChrchrBel	0	96	14
55	Carillon	0	97	14
56	Dulcimer	0	0	15
57	Dulcimer2	0	35	15
58	Cimbalom	0	96	15
59	Santur	0	97	15
60	DrawOrgn	0	0	16
61	DetDrwOr	0	32	16
62	60sDrOr1	0	33	16
63	60sDrOr2	0	34	16
64	70sDrOr1	0	35	16
65	DrawOrg2	0	36	16
66	60sDrOr3	0	37	16
67	EvenBar	0	38	16
68	16+2'2/3	0	40	16
69	Organ Ba	0	64	16
70	70sDrOr2	0	65	16
71	CheezOrg	0	66	16
72	DrawOrg3	0	67	16
73	PercOrgn	0	0	17
74	70sPcOr1	0	24	17
75	DetPrcOr	0	32	17
76	LiteOrg	0	33	17
77	PercOrg2	0	37	17
78	RockOrgn	0	0	18
79	RotaryOr	0	64	18
80	SloRotar	0	65	18
81	FstRotar	0	66	18
82	ChrchrOrg	0	0	19
83	ChurOrg3	0	32	19
84	ChurOrg2	0	35	19
85	NotreDam	0	40	19
86	OrgFlute	0	64	19
87	TrmOrgFl	0	65	19
88	ReedOrgn	0	0	20
89	Puff Org	0	40	20
90	Acordion	0	0	21
91	Accordlt	0	32	21
92	Harmnica	0	0	22
93	Harmo 2	0	32	22
94	TangoAcd	0	0	23
95	TngoAcd2	0	64	23
96	NylonGtr	0	0	24
97	NylonGt2	0	16	24
98	NylonGt3	0	25	24
99	VelGtHrm	0	43	24
100	Ukulele	0	96	24
101	SteelGtr	0	0	25
102	SteelGt2	0	16	25
103	12StrGtr	0	35	25
104	Nyln&Stl	0	40	25

Category Order	Voice Name	MSB#	LSB#	MIDI Program Change#
105	Stl&Body	0	41	25
106	Mandolin	0	96	25
107	Jazz Gtr	0	0	26
108	MelloGtr	0	18	26
109	JazzAmp	0	32	26
110	CleanGtr	0	0	27
111	ChorusGt	0	32	27
112	Mute.Gtr	0	0	28
113	FunkGtr1	0	40	28
114	MuteStlG	0	41	28
115	FunkGtr2	0	43	28
116	Jazz Man	0	45	28
117	Ovrdrive	0	0	29
118	Gt.Pinch	0	43	29
119	Dist.Gtr	0	0	30
120	FeedbkGt	0	40	30
121	FeedbkGt2	0	41	30
122	GtrHarmo	0	0	31
123	GtFeedbk	0	65	31
124	GtrHrmo2	0	66	31
125	Aco.Bass	0	0	32
126	JazzRthm	0	40	32
127	VXUprght	0	45	32
128	FngrBass	0	0	33
129	FingrDrk	0	18	33
130	FlangeBa	0	27	33
131	Ba&DstEG	0	40	33
132	FngrSlap	0	43	33
133	FngBass2	0	45	33
134	ModAlem	0	65	33
135	PickBass	0	0	34
136	MutePkBa	0	28	34
137	Fretless	0	0	35
138	Fretles2	0	32	35
139	Fretles3	0	33	35
140	Fretles4	0	34	35
141	SynFretl	0	96	35
142	Smooth	0	97	35
143	SlapBas1	0	0	36
144	ResoSlap	0	27	36
145	PunchThm	0	32	36
146	SlapBas2	0	0	37
147	VeloSlap	0	43	37
148	SynBass1	0	0	38
149	SynBa1Dk	0	18	38
150	FastResB	0	20	38
151	AcidBass	0	24	38
152	Clv Bass	0	35	38
153	TeknoBa	0	40	38
154	Oscar	0	64	38
155	SqrBass	0	65	38
156	RubberBa	0	66	38
157	Hammer	0	96	38
158	SynBass2	0	0	39

Category Order	Voice Name	MSB#	LSB#	MIDI Program Change#
159	MelloSB1	0	6	39
160	Seq Bass	0	12	39
161	ClkSynBa	0	18	39
162	SynBa2Dk	0	19	39
163	SmthBa 2	0	32	39
164	ModulrBa	0	40	39
165	DX Bass	0	41	39
166	X WireBa	0	64	39
167	Violin	0	0	40
168	SlowVln	0	8	40
169	Viola	0	0	41
170	Cello	0	0	42
171	Contrabs	0	0	43
172	Trem.Str	0	0	44
173	SlowTrStr	0	8	44
174	Susp Str	0	40	44
175	Pizz.Str	0	0	45
176	Harp	0	0	46
177	YangChin	0	40	46
178	Timpani	0	0	47
179	Strings1	0	0	48
180	S.Strngs	0	3	48
181	SlowStr	0	8	48
182	ArcoStr	0	24	48
183	60sStrng	0	35	48
184	Orchestr	0	40	48
185	Orchstr2	0	41	48
186	TremOrch	0	42	48
187	VeloStr	0	45	48
188	Strings2	0	0	49
189	S.SlwStr	0	3	49
190	LegatoSt	0	8	49
191	Warm Str	0	40	49
192	Kingdom	0	41	49
193	70s Str	0	64	49
194	Str Ens3	0	65	49
195	Syn.Str1	0	0	50
196	ResoStr	0	27	50
197	Syn Str4	0	64	50
198	SS Str	0	65	50
199	Syn.Str2	0	0	51
200	ChoirAah	0	0	52
201	S.Choir	0	3	52
202	Ch.Aahs2	0	16	52
203	MelChoir	0	32	52
204	ChoirStr	0	40	52
205	VoiceOoh	0	0	53
206	SynVoice	0	0	54
207	SynVox2	0	40	54
208	Choral	0	41	54
209	AnaVoice	0	64	54
210	Orch.Hit	0	0	55
211	OrchHit2	0	35	55
212	Impact	0	64	55

Category Order	Voice Name	MSB#	LSB#	MIDI Program Change#
213	Trumpet	0	0	56
214	Trumpet2	0	16	56
215	BriteTrp	0	17	56
216	WarmTrp	0	32	56
217	Trombone	0	0	57
218	Trmbone2	0	18	57
219	Tuba	0	0	58
220	Tuba 2	0	16	58
221	Mute.Trp	0	0	59
222	Fr.Horn	0	0	60
223	FrHrSolo	0	6	60
224	FrHorn2	0	32	60
225	HornOrch	0	37	60
226	BrasSect	0	0	61
227	Tp&TbSec	0	35	61
228	BrssSec2	0	40	61
229	HiBrass	0	41	61
230	MelloBrs	0	42	61
231	SynBras1	0	0	62
232	QuackBr	0	12	62
233	RezSynBr	0	20	62
234	PolyBrss	0	24	62
235	SynBras3	0	27	62
236	JumpBrss	0	32	62
237	AnaVelBr	0	45	62
238	AnaBrss1	0	64	62
239	SynBras2	0	0	63
240	Soft Brs	0	18	63
241	SynBrss4	0	40	63
242	ChoirBrs	0	41	63
243	VelBrss2	0	45	63
244	AnaBrss2	0	64	63
245	SprnoSax	0	0	64
246	Alto Sax	0	0	65
247	Sax Sect	0	40	65
248	HyprAlto	0	43	65
249	TenorSax	0	0	66
250	BrthTnSx	0	40	66
251	SoftTenr	0	41	66
252	TnrSax 2	0	64	66
253	Bari.Sax	0	0	67
254	Oboe	0	0	68
255	Eng.Horn	0	0	69
256	Bassoon	0	0	70
257	Clarinet	0	0	71
258	Piccolo	0	0	72
259	Flute	0	0	73
260	Recorder	0	0	74
261	PanFlute	0	0	75
262	Bottle	0	0	76
263	Shakhchi	0	0	77
264	Whistle	0	0	78
265	Ocarina	0	0	79
266	SquareLd	0	0	80

Voice List/Stimmenliste/Liste des voix

Category Order	Voice Name	MSB#	LSB#	MIDI Program Change#
267	Square 2	0	6	80
268	LMSquare	0	8	80
269	Hollow	0	18	80
270	Shmoog	0	19	80
271	Mellow	0	64	80
272	SoloSine	0	65	80
273	SineLead	0	66	80
274	Saw.Lead	0	0	81
275	Saw 2	0	6	81
276	ThickSaw	0	8	81
277	DynaSaw	0	18	81
278	DigiSaw	0	19	81
279	Big Lead	0	20	81
280	HeavySyn	0	24	81
281	WaspySyn	0	25	81
282	PulseSaw	0	40	81
283	Dr. Lead	0	41	81
284	VeloLead	0	45	81
285	Seq Ana	0	96	81
286	CaliopLd	0	0	82
287	Pure Pad	0	65	82
288	Chiff Ld	0	0	83
289	Rubby	0	64	83
290	CharanLd	0	0	84
291	DistLead	0	64	84
292	WireLead	0	65	84
293	Voice Ld	0	0	85
294	SynthAah	0	24	85
295	VoxLead	0	64	85
296	Fifth Ld	0	0	86
297	Big Five	0	35	86
298	Bass &Ld	0	0	87
299	Big&Low	0	16	87
300	Fat&Prky	0	64	87
301	SoftWurl	0	65	87
302	NewAgePd	0	0	88
303	Fantasy2	0	64	88
304	Warm Pad	0	0	89
305	ThickPad	0	16	89
306	Soft Pad	0	17	89
307	SinePad	0	18	89
308	Horn Pad	0	64	89
309	RotarStr	0	65	89
310	PolySyPd	0	0	90
311	PolyPd80	0	64	90
312	ClickPad	0	65	90
313	Ana Pad	0	66	90
314	SquarPad	0	67	90
315	ChoirPad	0	0	91
316	Heaven2	0	64	91
317	ltopia	0	66	91
318	CC Pad	0	67	91
319	BowedPad	0	0	92
320	Glacier	0	64	92

Category Order	Voice Name	MSB#	LSB#	MIDI Program Change#
321	GlassPad	0	65	92
322	MetalPad	0	0	93
323	Tine Pad	0	64	93
324	Pan Pad	0	65	93
325	Halo Pad	0	0	94
326	SweepPad	0	0	95
327	Shwimmer	0	20	95
328	Converge	0	27	95
329	PolarPad	0	64	95
330	Celstial	0	66	95
331	Rain	0	0	96
332	ClaviPad	0	45	96
333	HrmoRain	0	64	96
334	AfrcnWnd	0	65	96
335	Caribbean	0	66	96
336	SoundTrk	0	0	97
337	Prologue	0	27	97
338	Ancestrl	0	64	97
339	Crystal	0	0	98
340	SynDrCmp	0	12	98
341	Popcorn	0	14	98
342	TinyBell	0	18	98
343	RndGlock	0	35	98
344	GlockChi	0	40	98
345	ClearBel	0	41	98
346	ChorBell	0	42	98
347	SynMalet	0	64	98
348	SftCryst	0	65	98
349	LoudGlok	0	66	98
350	XmasBell	0	67	98
351	VibeBell	0	68	98
352	DigiBell	0	69	98
353	AirBells	0	70	98
354	BellHarp	0	71	98
355	Gamelmba	0	72	98
356	Atmosphr	0	0	99
357	WarmAtms	0	18	99
358	HollwRIs	0	19	99
359	NylonEP	0	40	99
360	NylnHarp	0	64	99
361	Harp Vox	0	65	99
362	AtmosPad	0	66	99
363	Planet	0	67	99
364	Bright	0	0	100
365	FantaBel	0	64	100
366	Smokey	0	96	100
367	Goblins	0	0	101
368	GobSyn	0	64	101
369	50sSciFi	0	65	101
370	Ring Pad	0	66	101
371	Ritual	0	67	101
372	ToHeaven	0	68	101
373	Night	0	70	101
374	Glisten	0	71	101

Category Order	Voice Name	MSB#	LSB#	MIDI Program Change#
375	BelChoir	0	96	101
376	Echoes	0	0	102
377	EchoPad2	0	8	102
378	Echo Pan	0	14	102
379	EchoBell	0	64	102
380	Big Pan	0	65	102
381	SynPiano	0	66	102
382	Creation	0	67	102
383	Stardust	0	68	102
384	Reso Pan	0	69	102
385	Sci-Fi	0	0	103
386	Starz	0	64	103
387	Sitar	0	0	104
388	DetSitar	0	32	104
389	Sitar 2	0	35	104
390	Tambra	0	96	104
391	Tamboura	0	97	104
392	Banjo	0	0	105
393	MuteBrjo	0	28	105
394	Rabab	0	96	105
395	Gopichnt	0	97	105
396	Oud	0	98	105
397	Shamisen	0	0	106
398	Koto	0	0	107
399	T. Koto	0	96	107
400	Kanoon	0	97	107
401	Kalimba	0	0	108
402	Bagpipe	0	0	109
403	Fiddle	0	0	110
404	Shanai	0	0	111
405	Shanai2	0	64	111
406	Pungi	0	96	111
407	Hichriki	0	97	111
408	TnklBell	0	0	112
409	Bonang	0	96	112
410	Gender	0	97	112
411	Gamelan	0	98	112
412	S.Gamlan	0	99	112
413	Rama Cym	0	100	112
414	AsianBel	0	101	112
415	Agogo	0	0	113
416	SteelDrm	0	0	114
417	GlasPerc	0	97	114
418	ThaiBell	0	98	114
419	WoodBlok	0	0	115
420	Castanet	0	96	115
421	TaikoDrm	0	0	116
422	Gr.Cassa	0	96	116
423	MelodTom	0	0	117
424	Mel Tom2	0	64	117
425	Real Tom	0	65	117
426	Rock Tom	0	66	117
427	Syn.Drum	0	0	118
428	Ana Tom	0	64	118

Category Order	Voice Name	MSB#	LSB#	MIDI Program Change#
429	ElecPerc	0	65	118
430	RevCymb1	0	0	119
431	FretNoiz	0	0	120
432	BrthNoiz	0	0	121
433	Seashore	0	0	122
434	Tweet	0	0	123
435	Telephone	0	0	124
436	Helicptr	0	0	125
437	Applause	0	0	126
438	Gunshot	0	0	127
439	CuttngNz	64	0	0
440	CttngNz2	64	0	1
441	Str Slap	64	0	3
442	Fl.KClk	64	0	16
443	Rain	64	0	32
444	Thunder	64	0	33
445	Wind	64	0	34
446	Stream	64	0	35
447	Bubble	64	0	36
448	Feed	64	0	37
449	Dog	64	0	48
450	Horse	64	0	49
451	Bird 2	64	0	50
452	Ghost	64	0	54
453	Maou	64	0	55
454	Tel.Dial	64	0	64
455	DoorSqek	64	0	65
456	Door Slam	64	0	66
457	Scratch	64	0	67
458	Scratch 2	64	0	68
459	WindChm	64	0	69
460	Telphon2	64	0	70
461	CarEngin	64	0	80
462	Car Stop	64	0	81
463	Car Pass	64	0	82
464	CarCrash	64	0	83
465	Siren	64	0	84
466	Train	64	0	85
467	Jetplane	64	0	86
468	Starship	64	0	87
469	Burst	64	0	88
470	Coaster	64	0	89
471	SbMarine	64	0	90
472	Laughing	64	0	96
473	Scream	64	0	97
474	Punch	64	0	98
475	Heart	64	0	99
476	FootStep	64	0	100
477	MchinGun	64	0	112
478	LaserGun	64	0	113
479	Xplosion	64	0	114
480	FireWork	64	0	115

Keyboard Drum Assignments/Tastatur-Drum-Belegung/

Bank Select MSB (0-127)					127	127	127	127	127	127
Bank Select LSB (0-127)					0	0	0	0	0	0
Program Change (1-128)					1	2	5	9	17	25
MIDI	Keyboard	Key	Alternate		Standard Kit 1	Standard Kit 2	Hit Kit	Room Kit	Rock Kit	Electro Kit
Note#	Note	Note	Off	Group						
13	C# -1	(C# 0)		3	Surdo Mute					
14	D -1	(D 0)		3	Surdo Open					
15	D# -1	(D# 0)			Hi Q					
16	E -1	(E 0)			Whip Slap					
17	F -1	(F 0)		4	Scratch H					
18	F# -1	(F# 0)		4	Scratch L					
19	G -1	(G 0)			Finger Snap					
20	G# -1	(G# 0)			Click Noise					
21	A -1	(A 0)			Metronome Click					
22	A# -1	(A# 0)			Metronome Bell					
23	B -1	(B 0)			Seq Click L					
24	C 0	C 1			Seq Click H					
25	C# 0	C# 1			Brush Tap					
26	D 0	D 1	O		Brush Swirl					
27	D# 0	D# 1			Brush Slap					
28	E 0	E 1	O		Brush Tap Swirl					Reverse Cymbal
29	F 0	F 1	O		Snare Roll					
30	F# 0	F# 1			Castanet					Hi Q 2
31	G 0	G 1			Snare Soft	Snare Soft 2	Snare Electro		Snare Noisy	Snare Snappy Electro
32	G# 0	G# 1			Sticks					
33	A 0	A 1			Kick Soft		Kick Tight L			Kick 3
34	A# 0	A# 1			Open Rim Shot	Open Rim Shot H Short	Snare Pitched			
35	B 0	B 1			Kick Tight		Kick Wet		Kick 2	Kick Gate
36	C 1	C 2			Kick	Kick Short	Kick Tight H		Kick Gate	Kick Gate Heavy
37	C# 1	C# 2			Side Stick	Side Stick Light	Stick Ambient			
38	D 1	D 2			Snare	Snare Short	Snare Ambient	Snare Snappy	Snare Rock	Snare Noisy 2
39	D# 1	D# 2			Hand Clap					
40	E 1	E 2			Snare Tight	Snare Tight H	Snare Tight 2	Snare Tight Snappy	Snare Rock Tight	Snare Noisy 3
41	F 1	F 2			Floor Tom L		Hybrid Tom 1	Tom Room 1	Tom Rock 1	Tom Electro 1
42	F# 1	F# 2		1	Hi-Hat Closed		Hi-Hat Closed 2			
43	G 1	G 2			Floor Tom H		Hybrid Tom 2	Tom Room 2	Tom Rock 2	Tom Electro 2
44	G# 1	G# 2		1	Hi-Hat Pedal		Hi-Hat Pedal 2			
45	A 1	A 2			Low Tom		Hybrid Tom 3	Tom Room 3	Tom Rock 3	Tom Electro 3
46	A# 1	A# 2		1	Hi-Hat Open		Hi-Hat Open 2			
47	B 1	B 2			Mid Tom L		Hybrid Tom 4	Tom Room 4	Tom Rock 4	Tom Electro 4
48	C 2	C 3			Mid Tom H		Hybrid Tom 5	Tom Room 5	Tom Rock 5	Tom Electro 5
49	C# 2	C# 3			Crash Cymbal 1					
50	D 2	D 3			High Tom		Hybrid Tom 6	Tom Room 6	Tom Rock 6	Tom Electro 6
51	D# 2	D# 3			Ride Cymbal 1					
52	E 2	E 3			Chinese Cymbal					
53	F 2	F 3			Ride Cymbal Cup					
54	F# 2	F# 3			Tambourine		Tambourine Light			
55	G 2	G 3			Splash Cymbal					
56	G# 2	G# 3			Cowbell					
57	A 2	A 3			Crash Cymbal 2					
58	A# 2	A# 3			Vibraslap					
59	B 2	B 3			Ride Cymbal 2					
60	C 3	C 4			Bongo H					
61	C# 3	C# 4			Bongo L					
62	D 3	D 4			Conga H Mute					
63	D# 3	D# 4			Conga H Open					
64	E 3	E 4			Conga L					
65	F 3	F 4			Timbale H					
66	F# 3	F# 4			Timbale L					
67	G 3	G 4			Agogo H					
68	G# 3	G# 4			Agogo L					
69	A 3	A 4			Cabasa					
70	A# 3	A# 4			Maracas					
71	B 3	B 4	O		Samba Whistle H					
72	C 4	C 5	O		Samba Whistle L					
73	C# 4	C# 5			Guiro Short					
74	D 4	D 5	O		Guiro Long					
75	D# 4	D# 5			Claves					
76	E 4	E 5			Wood Block H					
77	F 4	F 5			Wood Block L					
78	F# 4	F# 5			Cuica Mute					Scratch H 2
79	G 4	G 5			Cuica Open					Scratch L 2
80	G# 4	G# 5		2	Triangle Mute					
81	A 4	A 5		2	Triangle Open					
82	A# 4	A# 5			Shaker					
83	B 4	B 5			Jingle Bells					
84	C 5	C 6			Bell Tree					
85	C# 5	(C# 6)								
86	D 5	(D 6)								
87	D# 5	(D# 6)								
88	E 5	(E 6)								
89	F 5	(F 6)								
90	F# 5	(F# 6)								
91	G 5	(G 6)								

- Key Off: Keys marked "O" stop sounding the instant they are released.
- Alternate Group: Playing any instrument within a numbered group will immediately stop the sound of any other instrument in the same group of the same number.
- : Same as Standard Kit
- : No Sound
- StyleLvStd (MSB: 127, LSB: 0, PC: 124) is the same assignments as Live! Standard Kit.
- StyleLvFunk (MSB: 127, LSB: 0, PC: 125) is the same assignments as Live! Funk Kit.

- Key Off: Mit "O" bezeichnete Tasten hören sofort auf zu klingen, sobald sie losgelassen werden.
- Alternate Group: Wenn ein Instrument innerhalb einer nummerierten Gruppe gespielt wird, wird sofort der Klang jedes anderen Instruments mit derselben Nummer innerhalb dieser Gruppe gestoppt.
- : Entspricht dem Standard-Kit
- : Kein Klang
- StyleLvStd (MSB: 127, LSB: 0, PC: 124) ist die gleiche Zuordnung wie Live! Standard Kit.
- StyleLvFunk (MSB: 127, LSB: 0, PC: 125) ist die gleiche Zuordnung wie Live! Funk Kit.

Affectation des percussions de clavier

Bank Select MSB (0-127)					127	127	127	127	127	127
Bank Select LSB (0-127)					0	0	0	0	0	0
Program Change (1-128)					26	28	33	41	49	81 / 124
MIDI	Keyboard	Key	Alternate		Analog Kit	Dance Kit	Jazz Kit	Brush Kit	Symphony Kit	Live! Standard Kit
Note#	Note	Note	Off	Group						
13	C# -1	(C# 0)		3						
14	D -1	(D 0)		3						
15	D# -1	(D# 0)								
16	E -1	(E 0)								
17	F -1	(F 0)		4						
18	F# -1	(F# 0)		4						
19	G -1	(G 0)								
20	G# -1	(G# 0)								
21	A -1	(A 0)								
22	A# -1	(A# 0)								
23	B -1	(B 0)								
24	C 0	C 1								
25	C# 0	C# 1								Brush Tap Stereo
26	D 0	D 1	O							Brush Swirl Stereo
27	D# 0	D# 1								Brush Swirl Stereo
28	E 0	E 1	O		Reverse Cymbal	Reverse Cymbal				Brush Tap Swirl Stereo
29	F 0	F 1	O							Snare Roll Stereo
30	F# 0	F# 1			Hi Q 2	Hi Q 2				
31	G 0	G 1			Snare Noisy 4	Snare Techno	Snare Jazz H	Brush Slap 2		Snare L Stereo
32	G# 0	G# 1								
33	A 0	A 1			Kick 3	Kick Techno Q			Kick Soft 2	Kick Soft Stereo
34	A# 0	A# 1				Rim Gate		Open Rim Shot Light		Open Rim Shot Stereo
35	B 0	B 1			Kick Analog Short	Kick Techno L			Gran Cassa	Kick Light Stereo
36	C 1	C 2			Kick Analog	Kick Techno	Kick Jazz	Kick Jazz	Gran Cassa Mute	Kick Std Stereo
37	C# 1	C# 2			Side Stick Analog	Side Stick Analog	Side Stick Light	Side Stick Light		Side Stick Stereo
38	D 1	D 2			Snare Analog	Snare Clap	Snare Jazz L	Brush Slap 3	Band Snare	Snare M Stereo
39	D# 1	D# 2								
40	E 1	E 2			Snare Analog 2	Snare Dry	Snare Jazz M	Brush Tap 2	Band Snare 2	Snare H Stereo
41	F 1	F 2			Tom Analog 1	Tom Analog 1		Tom Brush 1		Floor Tom L Stereo
42	F# 1	F# 2	1		Hi-Hat Closed Analog	Hi-Hat Closed 3				Hi-Hat Closed Stereo
43	G 1	G 2			Tom Analog 2	Tom Analog 2		Tom Brush 2		Floor Tom H Stereo
44	G# 1	G# 2	1		Hi-Hat Closed Analog 2	Hi-Hat Closed Analog 3				Hi-Hat Pedal Stereo
45	A 1	A 2			Tom Analog 3	Tom Analog 3		Tom Brush 3		Low Tom Stereo
46	A# 1	A# 2	1		Hi-Hat Open Analog	Hi-Hat Open 3				Hi-Hat Open Stereo
47	B 1	B 2			Tom Analog 4	Tom Analog 4		Tom Brush 4		Mid Tom L Stereo
48	C 2	C 3			Tom Analog 5	Tom Analog 5		Tom Brush 5		Mid Tom H Stereo
49	C# 2	C# 3			Crash Analog	Crash Analog			Hand Cymbal	Crash Cymbal 1 Stereo
50	D 2	D 3			Tom Analog 6	Tom Analog 6		Tom Brush 6		High Tom Stereo
51	D# 2	D# 3							Hand Cymbal Short	Ride Cymbal 1 Stereo
52	E 2	E 3								Chinese Cymbal Stereo
53	F 2	F 3								Ride Cymbal Cup Stereo
54	F# 2	F# 3								
55	G 2	G 3								Splash Cymbal Stereo
56	G# 2	G# 3			Cowbell Analog	Cowbell Analog				
57	A 2	A 3							Hand Cymbal 2	Crash Cymbal 2 Stereo
58	A# 2	A# 3								
59	B 2	B 3							Hand Cymbal 2 Short	Ride Cymbal 2 Stereo
60	C 3	C 4								
61	C# 3	C# 4								
62	D 3	D 4			Conga Analog H	Conga Analog H				
63	D# 3	D# 4			Conga Analog M	Conga Analog M				
64	E 3	E 4			Conga Analog L	Conga Analog L				
65	F 3	F 4								
66	F# 3	F# 4								
67	G 3	G 4								
68	G# 3	G# 4								
69	A 3	A 4								
70	A# 3	A# 4			Maracas 2	Maracas 2				
71	B 3	B 4	O							
72	C 4	C 5	O							
73	C# 4	C# 5								
74	D 4	D 5	O							
75	D# 4	D# 5			Claves 2	Claves 2				
76	E 4	E 5								
77	F 4	F 5								
78	F# 4	F# 5			Scratch H 2	Scratch H 2				
79	G 4	G 5			Scratch L 2	Scratch L 2				
80	G# 4	G# 5		2						
81	A 4	A 5		2						
82	A# 4	A# 5								
83	B 4	B 5								
84	C 5	C 6								
85	C# 5	(C# 6)								
86	D 5	(D 6)								
87	D# 5	(D# 6)								
88	E 5	(E 6)								
89	F 5	(F 6)								
90	F# 5	(F# 6)								
91	G 5	(G 6)								

- Note coupée : les notes marquées " O " sont inaudibles dès l'instant où elles sont relâchées.
- Groupe alternatif : jouer d'un instrument dans un groupe numéroté provoque la coupure immédiate du son de tout autre instrument du même groupe de même numéro.
- : comme kit standard
- : aucun son
- StyleLvStd (MSB : 127, LSB : 0, PC : 124) correspond au kit Live ! Standard.
- StyleLvFunk (MSB : 127, LSB : 0, PC : 125) correspond au kit Live ! Funk.

Keyboard Drum Assignments/Tastatur-Drum-Belegung/Affectation des percussions de clavier

Bank Select MSB (0-127)					127	127	127	127	127
Bank Select LSB (0-127)					0	0	0	0	0
Program Change (1-128)					1	82 / 125	83	84 / 126	85 / 127
MIDI	Keyboard	Key	Alternate		Standard Kit 1	Live! Funk Kit	Live! Brush Kit	Live! Standard + Percussion Kit	Live! Funk + Percussion Kit
Note#	Note	Note	Off	Group					
13	C# -1	(C# 0)		3	Surdo Mute				
14	D -1	(D 0)		3	Surdo Open				
15	D# -1	(D# 0)			Hi Q				
16	E -1	(E 0)			Whip Slap				
17	F -1	(F 0)		4	Scratch H				
18	F# -1	(F# 0)		4	Scratch L				
19	G -1	(G 0)			Finger Snap				
20	G# -1	(G# 0)			Click Noise				
21	A -1	(A 0)			Metronome Click				
22	A# -1	(A# 0)			Metronome Bell				
23	B -1	(B 0)			Seq Click L				
24	C 0	C 1			Seq Click H				
25	C# 0	C# 1			Brush Tap	Brush Tap Stereo	Brush Tap Stereo	Brush Tap Stereo	Brush Tap Stereo
26	D 0	D 1	O		Brush Swirl	Brush Swirl Stereo	Brush Swirl Stereo	Brush Swirl Stereo	Brush Swirl Stereo
27	D# 0	D# 1			Brush Slap	Brush Slap Stereo	Brush Slap Stereo	Brush Slap Stereo	Brush Slap Stereo
28	E 0	E 1	O		Brush Tap Swirl	Brush Tap Swirl Stereo	Brush Tap Swirl Stereo	Brush Tap Swirl Stereo	Brush Tap Swirl Stereo
29	F 0	F 1	O		Snare Roll	Snare Roll Stereo	Snare Roll Stereo	Snare Roll Stereo	Snare Roll Stereo
30	F# 0	F# 1			Castanet				
31	G 0	G 1			Snare Soft	Snare Funk L Stereo	Brush Slap 2 Stereo	Snare L Stereo	Snare L Stereo
32	G# 0	G# 1			Sticks				
33	A 0	A 1			Kick Soft	Kick Soft Stereo	Kick Soft Stereo	Kick Soft Stereo	Kick Soft Stereo
34	A# 0	A# 1			Open Rim Shot	Open Rim Shot Stereo	Open Rim Shot Stereo	Open Rim Shot Stereo	Open Rim Shot Stereo
35	B 0	B 1			Kick Tight	Kick Std Stereo	Kick Std Stereo	Kick Light Stereo	Kick Std Stereo
36	C 1	C 2			Kick	Kick Funk Stereo	Kick Funk Stereo	Kick Std Stereo	Kick Funk Stereo
37	C# 1	C# 2			Side Stick	Side Stick Stereo	Side Stick Stereo	Side Stick Stereo	Side Stick Stereo
38	D 1	D 2			Snare	Snare Funk M Stereo	Snare Brush M Stereo	Snare M Stereo	Snare Funk M Stereo
39	D# 1	D# 2			Hand Clap			Hand Clap Stereo	Hand Clap Stereo
40	E 1	E 2			Snare Tight	Snare Funk H Stereo	Snare Brush H Stereo	Snare H Stereo	Snare Funk H Stereo
41	F 1	F 2			Floor Tom L	Floor Tom L Stereo	Brush Floor Tom L Stereo	Floor Tom L Stereo	Floor Tom L Stereo
42	F# 1	F# 2		1	Hi-Hat Closed	Hi-Hat Closed Stereo	Hi-Hat Closed Stereo	Hi-Hat Closed Stereo	Hi-Hat Closed Stereo
43	G 1	G 2			Floor Tom H	Floor Tom H Stereo	Brush Floor Tom H Stereo	Floor Tom H Stereo	Floor Tom H Stereo
44	G# 1	G# 2		1	Hi-Hat Pedal	Hi-Hat Pedal Stereo	Hi-Hat Pedal Stereo	Hi-Hat Pedal Stereo	Hi-Hat Pedal Stereo
45	A 1	A 2			Low Tom	Low Tom Stereo	Brush Low Tom Stereo	Low Tom Stereo	Low Tom Stereo
46	A# 1	A# 2		1	Hi-Hat Open	Hi-Hat Open Stereo	Hi-Hat Open Stereo	Hi-Hat Open Stereo	Hi-Hat Open Stereo
47	B 1	B 2			Mid Tom L	Mid Tom L Stereo	Brush Mid Tom L Stereo	Mid Tom L Stereo	Mid Tom L Stereo
48	C 2	C 3			Mid Tom H	Mid Tom H Stereo	Brush Mid Tom H Stereo	Mid Tom H Stereo	Mid Tom H Stereo
49	C# 2	C# 3			Crash Cymbal 1	Crash Cymbal 1 Stereo	Brush Crash Cymbal 1 Stereo	Crash Cymbal 1 Stereo	Crash Cymbal 1 Stereo
50	D 2	D 3			High Tom	High Tom Stereo	Brush High Tom Stereo	High Tom Stereo	High Tom Stereo
51	D# 2	D# 3			Ride Cymbal 1	Ride Cymbal 1 Stereo	Brush Ride Cymbal 1 Stereo	Ride Cymbal 1 Stereo	Ride Cymbal 1 Stereo
52	E 2	E 3			Chinese Cymbal	Chinese Cymbal Stereo	Chinese Cymbal Stereo	Chinese Cymbal Stereo	Chinese Cymbal Stereo
53	F 2	F 3			Ride Cymbal Cup	Ride Cymbal Cup Stereo	Brush Ride Cymbal Cup Stereo	Ride Cymbal Cup Stereo	Ride Cymbal Cup Stereo
54	F# 2	F# 3			Tambourine			Tambourine Stereo	Tambourine Stereo
55	G 2	G 3			Splash Cymbal	Splash Cymbal Stereo	Splash Cymbal Stereo	Splash Cymbal Stereo	Splash Cymbal Stereo
56	G# 2	G# 3			Cowbell			Cowbell Stereo	Cowbell Stereo
57	A 2	A 3			Crash Cymbal 2	Crash Cymbal 2 Stereo	Brush Crash Cymbal 2 Stereo	Crash Cymbal 2 Stereo	Crash Cymbal 2 Stereo
58	A# 2	A# 3			Vibraslap				
59	B 2	B 3			Ride Cymbal 2	Ride Cymbal 2 Stereo	Brush Ride Cymbal 2 Stereo	Ride Cymbal 2 Stereo	Ride Cymbal 2 Stereo
60	C 3	C 4			Bongo H			Bongo H Stereo	Bongo H Stereo
61	C# 3	C# 4			Bongo L			Bongo L Stereo	Bongo L Stereo
62	D 3	D 4			Conga H Mute			Conga H Mute Stereo	Conga H Mute Stereo
63	D# 3	D# 4			Conga H Open			Conga H Open Stereo	Conga H Open Stereo
64	E 3	E 4			Conga L			Conga L Stereo	Conga L Stereo
65	F 3	F 4			Timbale H			Timbale H Stereo	Timbale H Stereo
66	F# 3	F# 4			Timbale L			Timbale L Stereo	Timbale L Stereo
67	G 3	G 4			Agogo H				
68	G# 3	G# 4			Agogo L				
69	A 3	A 4			Cabasa			Cabasa Stereo	Cabasa Stereo
70	A# 3	A# 4			Maracas			Maracas Stereo	Maracas Stereo
71	B 3	B 4	O		Samba Whistle H				
72	C 4	C 5	O		Samba Whistle L				
73	C# 4	C# 5			Guiro Short			Guiro Short Stereo	Guiro Short Stereo
74	D 4	D 5	O		Guiro Long			Guiro Long Stereo	Guiro Long Stereo
75	D# 4	D# 5			Claves				
76	E 4	E 5			Wood Block H				
77	F 4	F 5			Wood Block L				
78	F# 4	F# 5			Cuica Mute			Cuica Mute Stereo	Cuica Mute Stereo
79	G 4	G 5			Cuica Open			Cuica Open Stereo	Cuica Open Stereo
80	G# 4	G# 5		2	Triangle Mute			Triangle Mute Stereo	Triangle Mute Stereo
81	A 4	A 5		2	Triangle Open			Triangle Open Stereo	Triangle Open Stereo
82	A# 4	A# 5			Shaker			Shaker Stereo	Shaker Stereo
83	B 4	B 5			Jingle Bells				
84	C 5	C 6			Bell Tree			Wind Chime Stereo	Wind Chime Stereo
85	C# 5	(C# 6)							
86	D 5	(D 6)							
87	D# 5	(D# 6)							
88	E 5	(E 6)							
89	F 5	(F 6)							
90	F# 5	(F# 6)							
91	G 5	(G 6)							

Keyboard Drum Assignments/Tastatur-Drum-Belegung/Affectation des percussions de clavier

Bank Select MSB (0-127)					127	126	126	126	126	126	126
Bank Select LSB (0-127)					0	0	0	0	0	0	0
Program Change (1-128)					86	36	1	2	41	44	
MIDI Note#	Note	Keyboard Note	Key Off	Alternate Group	Live! Brush + Percussion Kit	Arabic Kit	SFX Kit 1	SFX Kit 2	Live! AfroCuban Kit	Live! PopLatin Kit	
13	C# -1	(C# 0)		3							
14	D -1	(D 0)		3							
15	D# -1	(D# 0)									
16	E -1	(E 0)									
17	F -1	(F 0)		4							
18	F# -1	(F# 0)		4							Hand Clap Stereo
19	G -1	(G 0)									
20	G# -1	(G# 0)									
21	A -1	(A 0)									
22	A# -1	(A# 0)							Conga H Tip Stereo	Conga H Tip Stereo	
23	B -1	(B 0)							Conga H Heel Stereo	Conga H Heel Stereo	
24	C 0	C 1				Nakarazan Dom			Conga H Open Stereo	Conga H Open Stereo	
25	C# 0	C# 1			Brush Tap Stereo	Cabasa			Conga H Mute Stereo	Conga H Mute Stereo	
26	D 0	D 1	O		Brush Swirl Stereo	Nakarazan Edge			Conga H Slap Open Stereo	Conga H Slap Open Stereo	
27	D# 0	D# 1			Brush Slap Stereo	Hager Dom			Conga H Slap Stereo	Conga H Slap Stereo	
28	E 0	E 1	O		Brush Tap Swirl Stereo	Hager Edge			Conga H Slap Mute Stereo	Conga H Slap Mute Stereo	
29	F 0	F 1	O		Snare Roll Stereo	Bongo H			Conga L Tip Stereo	Conga L Tip Stereo	
30	F# 0	F# 1				Bongo L			Conga L Heel Stereo	Conga L Heel Stereo	
31	G 0	G 1			Brush Slap 2 Stereo	Conga H Mute			Conga L Open Stereo	Conga L Open Stereo	
32	G# 0	G# 1				Conga H Open			Conga L Mute Stereo	Conga L Mute Stereo	
33	A 0	A 1			Kick Soft Stereo	Conga L			Conga L Slap Open Stereo	Conga L Slap Open Stereo	
34	A# 0	A# 1			Open Rim Shot Stereo	Zagrouda H			Conga L Slap Stereo	Conga L Slap Stereo	
35	B 0	B 1			Kick Std Stereo	Zagrouda L			Conga L Slide Stereo	Conga L Slide Stereo	
36	C 1	C 2			Kick Funk Stereo	Kick Soft	Cutting Noise	Phone Call	Bongo H Open 1 Finger Stereo	Bongo H Open 1 finger Stereo	
37	C# 1	C# 2			Side Stick Stereo	Side Stick	Cutting Noise 2	Door Squeak	Bongo H Open 3 Finger Stereo	Bongo H Open 3 finger Stereo	
38	D 1	D 2			Snare Brush M Stereo	Snare Soft		Door Slam	Bongo H Rim Stereo	Bongo H Rim Stereo	
39	D# 1	D# 2			Hand Clap Stereo	Arabic Hand Clap	String Slap	Scratch Cut	Bongo H Tip Stereo	Bongo H Tip Stereo	
40	E 1	E 2			Snare Brush H Stereo	Snare		Scratch H 3	Bongo H Heel Stereo	Bongo H Heel Stereo	
41	F 1	F 2			Brush Floor Tom L Stereo	Floor Tom L		Wind Chime	Bongo H Slap Stereo	Bongo H Slap Stereo	
42	F# 1	F# 2		1	Hi-Hat Closed Stereo	Hi-Hat Closed		Telephone Ring 2	Bongo L Open 1 Finger Stereo	Bongo L Open 1 finger Stereo	
43	G 1	G 2			Brush Floor Tom H Stereo	Floor Tom H			Bongo L Open 3 Finger Stereo	Bongo L Open 3 finger Stereo	
44	G# 1	G# 2		1	Hi-Hat Pedal Stereo	Hi-Hat Pedal			Bongo L Rim Stereo	Bongo L Rim Stereo	
45	A 1	A 2			Brush Low Tom Stereo	Low Tom			Bongo L Tip Stereo	Bongo L Tip Stereo	
46	A# 1	A# 2		1	Hi-Hat Open Stereo	Hi-Hat Open			Bongo L Heel Stereo	Bongo L Heel Stereo	
47	B 1	B 2			Brush Mid Tom L Stereo	Mid Tom L			Bongo L Slap Stereo	Bongo L Slap Stereo	
48	C 2	C 3			Brush Mid Tom H Stereo	Mid Tom H			Timbale L Open Stereo	Timbale L Open Stereo	
49	C# 2	C# 3			Brush Crash Cymbal 1 Stereo	Crash Cymbal 1					
50	D 2	D 3			Brush High Tom Stereo	High Tom					
51	D# 2	D# 3			Brush Ride Cymbal 1 Stereo	Ride Cymbal 1					
52	E 2	E 3			Chinese Cymbal Stereo	Crash Cymbal 2	Flute Key Click	Car Engine Ignition			
53	F 2	F 3			Brush Ride Cymbal Cup Stereo	Duhulla Dom		Car Tires Squeal			
54	F# 2	F# 3			Tambourine Stereo	Tambourine		Car Passing	Timbale H Open Stereo	Timbale H Open Stereo	
55	G 2	G 3			Splash Cymbal Stereo	Duhulla Tak		Car Crash			
56	G# 2	G# 3			Cowbell Stereo	Cowbell		Siren			
57	A 2	A 3			Brush Crash Cymbal 2 Stereo	Duhulla Sak		Train			
58	A# 2	A# 3				Claves		Jet Plane			
59	B 2	B 3			Brush Ride Cymbal 2 Stereo	Doff Dom		Starship			
60	C 3	C 4			Bongo H Stereo	Katem Dom		Burst	Cowbell Top Stereo	Cowbell Top Stereo	
61	C# 3	C# 4			Bongo L Stereo	Katem Tak		Roller Coaster			
62	D 3	D 4			Conga H Mute Stereo	Katem Sak		Submarine			
63	D# 3	D# 4			Conga H Open Stereo	Katem Tak					
64	E 3	E 4			Conga L Stereo	Doff Tak			Guiro Short Stereo	Guiro Short Stereo	
65	F 3	F 4			Timbale H Stereo	Tabla Dom			Guiro Long Stereo	Guiro Long Stereo	
66	F# 3	F# 4			Timbale L Stereo	Tabla Tak1					
67	G 3	G 4				Tabla Tik					
68	G# 3	G# 4				Tabla Tak2	Shower	Laugh	Tambourine Stereo	Tambourine Stereo	
69	A 3	A 4			Cabasa Stereo	Tabla Sak	Thunder	Scream			
70	A# 3	A# 4			Maracas Stereo	Tabla Roll of Edge	Wind	Punch			
71	B 3	B 4	O			Tabla Flam	Stream	Heart Beat			
72	C 4	C 5	O			Sagat 1	Bubble	Foot Steps	Maracas Stereo	Maracas Stereo	
73	C# 4	C# 5			Guiro Short Stereo	Tabel Dom	Feed		Shaker Stereo	Shaker Stereo	
74	D 4	D 5	O		Guiro Long Stereo	Sagat 3			Cabasa Stereo	Cabasa Stereo	
75	D# 4	D# 5				Tabel Tak					
76	E 4	E 5				Sagat 2					
77	F 4	F 5				Rik Dom					
78	F# 4	F# 5			Cuica Mute Stereo	Rik Tak 2					
79	G 4	G 5			Cuica Open Stereo	Rik Finger 1					
80	G# 4	G# 5		2	Triangle Mute Stereo	Rik Tak 1					
81	A 4	A 5		2	Triangle Open Stereo	Rik Finger 2					
82	A# 4	A# 5			Shaker Stereo	Rik Brass Tremolo					Triangle Mute Stereo
83	B 4	B 5				Rik Sak					Triangle Open Stereo
84	C 5	C 6			Wind Chime Stereo	Rik Tik	Dog	Machine Gun			Wind Chime Stereo
85	C# 5	(C# 6)					Horse	Laser Gun			
86	D 5	(D 6)					Bird Tweet 2	Explosion			
87	D# 5	(D# 6)						Firework			
88	E 5	(E 6)									
89	F 5	(F 6)									
90	F# 5	(F# 6)					Ghost				
91	G 5	(G 6)					Maou				

Plug-in Voice List/Plug-In-Stimmenliste/Liste des voix plug-in

The voices in the list below are created by loading the data from the included "Plug-in Custom Voice Disk" to the 9000Pro via the Plug-in Manager function (page 66).

Die Stimmen in der untenstehenden Liste werden erzeugt, indem die Daten von der beiliegenden Diskette „Plug-In-Benutzerstimme“ mit Hilfe der Plug-In-Managerfunktion in das 9000Pro geladen werden (siehe Seite 66).

Les voix figurant dans la liste suivante sont créées en chargeant les données de la disquette « Plug-in Custom Voice Disk » (Disquette des voix plug-in personnalisées) sur le 9000Pro via la fonction Plug-in Manager (Gestionnaire plug-in) (page 66).

● PLG150-VL Plug in Voice List

Category Order	Voice Name	MSB#	LSB#	MIDI Program Change#
I (Brass)				
1	VL! Trumpet	33	1	4
2	VL!Trombone	33	1	7
3	VL! JzTrpt	33	1	20
4	MuteTrumpet	33	1	24
5	VL! Trumpy	33	0	86
6	VL! Brass	33	1	26
7	VL! Horn	33	1	27
8	Trumpet 2	33	1	16
9	FlugelHorn!	33	1	17
10	Tuba!	33	1	31
II (Saxophone 1)				
1	VL!Soprano	81	112	64
2	VL!AltoSax	81	112	65
3	Motion Sax!	81	115	66
4	BrightTenor	33	1	86
5	Jazz Sax	81	114	66
6	Soprano Sax	81	113	64
7	Alto Sax	81	114	65
8	Ana Sopran	33	1	69
9	Soft Alto	81	113	65
10	Tenor Sax	81	116	66
III (Saxophone 2)				
1	Old Tenor	81	119	66
2	Air Sax	33	1	9
3	Glass Alto	33	1	75
4	Voxo Saxo	81	113	67
5	Bari Sax	81	112	67
6	Mizu Horn	33	1	113
7	Funny Sax	33	0	114
8	SopranoPipe	81	114	64
9	Floboe	33	1	1
10	SylophonX	33	1	115
IV (Pipe 1)				
1	Jazz Flute	33	1	48
2	Pan Pipe	33	1	55
3	BambooFlute	33	1	57
4	Shakuha!	33	0	126
5	Pico Pipe	33	0	113
6	Snake Flute	33	1	12
7	Duality	33	0	116
8	Flauto	33	1	46

Category Order	Voice Name	MSB#	LSB#	MIDI Program Change#
9	Recorder!	33	1	105
10	Island Pipe	33	1	102
V (Pipe 2)				
1	VL!Clarinet	33	1	98
2	Piccolo	33	1	43
3	Clariphone	33	0	91
4	Clariophon	33	1	100
5	Alt Kwek	33	0	117
6	Whystler	33	0	12
7	Flurmod	33	1	61
8	Lite Pipe	33	1	99
9	Ocarina	33	1	109
10	Resoflute	33	0	93
11	Bass Clari	33	0	122
12	Binaphon	33	0	109
VI (Reed)				
1	VL! Oboe	33	1	89
2	VL!EnglHorn	33	1	95
3	VL!Bassoon	33	1	97
4	Triple Reed	33	1	94
5	Oboette	33	0	127
6	Baroquen	33	1	63
7	Bassoon	33	1	97
8	Ali Baba	33	0	111
9	Noboe	33	1	91
10	Persinet	33	0	112
VII (Guitar)				
1	VL!Span.Gtr	33	0	71
2	VL! JGuitar	33	0	78
3	GuitarChuck	33	0	80
4	Smooth Gtr	33	0	76
5	Jazz Guitar	33	0	72
6	FunkyGuitar	33	0	77
7	Guitar Hero	33	0	3
8	ChaosGuitar	33	0	11
9	Synpick	33	0	96
10	VL! Slapper	33	0	9
VIII (Ethnnc&Str)				
1	Stone Henge	33	0	4
2	Sitar!	33	0	58
3	Rock Harp	33	1	121
4	Akko Harp	33	1	59

Plug-in Voice List/Plug-In-Stimmenliste/Liste des voix plug-in

Category Order	Voice Name	MSB#	LSB#	MIDI Program Change#
5	Plucked	33	0	74
6	VLI Shaku	33	1	54
7	ElectrumX	33	0	120
8	Violon	33	1	37
9	Yam Gam	33	0	60
10	Edgeophon	33	0	121
11	Akkophon	33	1	59
12	Squeeze	33	1	117
13	Parlophon	33	0	88
14	Softblow	33	0	118
15	NuViolin	33	1	32
IX (Synthesizer)				
1	Chamlion	33	0	51
2	Choronic	33	0	90
3	Fat Mini	33	0	87
4	Wynth	33	0	14
5	SynTouch	33	0	89
6	Talk Box	33	0	84
7	Brassyn	33	0	105
8	Maysbe	33	1	112
9	Resogrowl	33	0	94
10	Obosyn	33	0	106
11	SilverSyn	33	0	102
12	AnaPercSyn	33	0	23
13	Babalog	33	0	25
14	Celloid	33	0	83
15	Klaqak	33	0	57
16	MWh Morph	33	0	70
17	BuzzWheel	33	0	15
18	Jason Mod	33	0	69
19	Square Lead	33	0	19
20	Phasepipe	33	0	12
X (Bass 1)				
1	Finger Bass	33	0	26
2	Damp Bass	33	0	31
3	Acid Bass	33	0	42
4	Dirty Bass	33	0	53
5	Lead Bass	33	0	18
6	Parasynbass	33	0	52
7	Square Bass	33	0	43
8	SynkBass	33	0	55
9	Tek Bass	33	0	49
10	Tranz Bass	33	0	50
XI (Bass 2)				
1	VLI!BamBass	33	0	54
2	Dance Bass	33	0	51
3	Fruit Bass	33	0	41
4	Box Bass	33	0	39
5	Birdland	33	0	29
6	Talk Bass	33	0	6
7	Bamboo Bass	33	0	54
8	Buzz Bass	33	0	37
9	Clav Bass	33	0	7
10	Dragon Bass	33	0	7

Plug-in Voice List/Plug-In-Stimmenliste/Liste des voix plug-in

● PLG150-AN Plug in Voice List

Category Order	Voice Name	MSB#	LSB#	MIDI Program Change#
I				
1	Killer	36	2	0
2	RealMini	36	0	41
3	5th Pad	36	2	1
4	Lights	36	2	2
5	Metallic	36	2	3
6	Hyperbolic	36	1	127
7	Cactus	36	2	4
8	Mini Low	36	0	52
9	Omega	36	2	5
10	Brainmill	36	2	6
11	Power	36	2	7
12	Lotus	36	1	124
13	Filterflow	36	2	8
14	Kraftworks	36	2	9
15	Hard Noize	36	2	10
16	TechPluck	36	2	11
17	Xalimba	36	2	12
18	Dist5th	36	1	121
19	Sliver	36	0	71
20	BPF Step	36	2	13
II				
1	Wonder	36	0	47
2	Elec Groove	36	2	14
3	Seq Bass	36	2	15
4	Cool man	36	2	16
5	Uni Bass	36	1	126
6	Free Cut	36	2	17
7	Kick Line	36	0	123
8	Zebedee	36	2	18
9	Touch	36	0	33
10	Chiff	36	0	92
11	Sync Eko	36	1	49
12	FreeRthm	36	1	108
13	Virtual	36	2	19
14	JarreSQ	36	2	20
15	Hardcore	36	2	21
16	Kangaroo	36	0	119
17	Acid Seq	36	2	22
18	Acid Rain	36	2	23
19	Harmsync	36	0	122
20	Fat Run	36	2	24
III				
1	Bombastic	36	0	10
2	Sync Lead	36	2	25
3	Squeamer	36	0	12
4	Dre-full	36	0	13
5	SynGtr	36	0	37
6	Xenarion	36	2	26
7	Caner	36	0	75
8	J.Hammer	36	0	84
9	On One	36	2	27
10	SupaSync	36	2	28
11	Prophetic	36	2	29
12	Slum	36	2	30
13	Lipstick	36	0	16
14	MegaDron	36	0	95
15	Unstable	36	0	25

Category Order	Voice Name	MSB#	LSB#	MIDI Program Change#
16	2001	36	0	2
17	Ruff	36	0	4
18	Grumpy	36	2	31
19	Cosmic	36	2	32
20	VA Pig	36	2	33
IV				
1	Dirty Saw	36	2	34
2	OldOkt	36	2	35
3	Resonant	36	1	51
4	SepaWays	36	2	36
5	Maxx	36	0	43
6	DistOdsy	36	1	16
7	Violynx	36	1	21
8	Pro Sync	36	1	22
9	Susy	36	0	78
10	Mars	36	1	53
11	Dawn	36	1	48
12	Saphire	36	2	37
13	Ropey	36	2	38
14	Pulsate	36	2	39
15	Faaat	36	2	40
16	BlapMoth	36	2	41
17	MaMa	36	2	42
18	Yellow	36	1	42
19	Stranger	36	2	43
20	Earth Lead	36	0	79
V				
1	Rhubarb	36	2	44
2	Trabant	36	0	85
3	Billy	36	0	98
4	Nossi	36	0	71
5	CyberBag	36	2	45
6	Cream	36	2	46
7	Astro Flute	36	2	47
8	Bella	36	2	48
9	MgWhistl	36	2	49
10	Mg Cat	36	2	50
11	Chamleon	36	2	51
12	Earthling	36	1	107
13	BiggMac	36	0	6
14	Maise	36	0	9
15	Silence	36	2	52
16	KnivesLd	36	2	53
17	ANSyncHd	36	2	54
18	Caliopsyn	36	0	91
19	Oizo	36	2	55
20	Jack	36	0	27
VI				
1	Fatty	36	0	105
2	Bronze	36	0	107
3	HardBrss	36	0	17
4	ToToHorn	36	2	56
5	CS80Bras	36	2	57
6	ProBrass	36	1	23
7	Smoovey	36	2	58
8	Chick	36	0	77
9	Sharpsyn	36	1	50
10	SQR	36	0	46

Plug-in Voice List/Plug-In-Stimmenliste/Liste des voix plug-in

Category Order	Voice Name	MSB#	LSB#	MIDI Program Change#
11	SyncBrPd	36	1	45
12	Stevie	36	0	66
13	Willy	36	2	59
14	Pulser	36	2	60
15	Lucky	36	0	72
16	Zoik	36	2	61
17	Rock It	36	2	62
18	ANSofBr	36	0	108
19	Fire	36	2	63
20	ObDetune	36	1	17
VII				
1	AnalogBrass	36	0	109
2	Soar	36	1	46
3	Major Brass	36	2	64
4	High Sweep	36	1	55
5	Waspad	36	0	55
6	Sync Sweep	36	1	56
7	Mountain	36	1	57
8	BPF Pad	36	2	65
9	Down Under	36	1	80
10	Chocolate	36	0	111
11	Water Pad	36	1	54
12	Vangelizm	36	1	52
13	P-5 Saw	36	0	80
14	Kelp	36	1	44
15	Magic	36	1	41
16	PWM Sweep	36	0	22
17	Multi Saw	36	2	66
18	So-Lina	36	0	19
19	Hi Wedge	36	1	18
20	Bonn	36	2	67
VIII				
1	PWM Strings	36	0	115
2	Funky	36	2	68
3	Insomnia	36	2	69
4	Pro Attack	36	1	20
5	Popcorn	36	0	73
6	Snowball	36	2	70
7	Woob	36	1	83
8	MiniTech	36	2	71
9	Cavesyn	36	2	72
10	Cracker	36	2	73
11	MgSoloLd	36	2	74
12	Behind	36	2	75
13	Rydeen	36	2	76
14	Knives	36	2	77
15	Mg Wood	36	2	78
16	Monty	36	2	79
17	Q Lead	36	2	80
18	5th Ring	36	1	15
19	FootBase	36	2	81
20	10thTone	36	0	54
IX				
1	Mr.Hook	36	2	82
2	Hypertune	36	2	83
3	Pastel	36	0	93
4	Abacab	36	0	102
5	Laos	36	0	23

Category Order	Voice Name	MSB#	LSB#	MIDI Program Change#
6	X-Bass	36	0	49
7	ANSynBas	36	0	40
8	Dog Bass	36	2	84
9	DuckBass	36	2	85
10	RubbaBas	36	0	58
11	Stringer	36	0	112
12	Mg Fretless	36	2	86
13	BirdWorld	36	0	56
14	Woodbass	36	0	57
15	Smooth	36	0	59
16	Hardily	36	2	87
17	Loom	36	1	24
18	SeqWater	36	2	88
19	EthTeck	36	2	89
20	India	36	2	90
X				
1	HiQ Reso	36	0	29
2	SynthTom	36	2	91
3	SynShake	36	2	92
4	TriblTom	36	1	85
5	AN Snare	36	2	93
6	MufflKik	36	1	91
7	Euro kik	36	1	92
8	AN HiHat	36	1	93
9	Mechanics	36	1	104
10	Seismic	36	1	116
11	X Bells	36	2	94
12	XmodBell	36	2	95
13	PitchMan	36	0	86
14	Metal Ld	36	0	96
15	EthnoTom	36	1	36
16	AN Toms	36	1	87
17	Rimshot	36	1	89
18	XstikSnr	36	1	90
19	Cyberclock	36	1	106
20	Fhomhair	36	0	89
XI				
1	Lunar X41	36	1	102
2	Quarks	36	1	109
3	ULTSound	36	2	96
4	Invade	36	0	31
5	PlyChord	36	1	100
6	Poptart	36	2	97
7	Jah	36	2	98
8	FreeEdge	36	0	32
9	Fumble	36	0	30
10	WelcomBk	36	2	99
11	RadioNz	36	1	96
12	FM Waves	36	1	103
13	MgVoice	36	1	8
14	ResoBell	36	2	100
15	Microdot	36	1	73
16	Syncrome	36	1	75
17	RhthmCty	36	1	76
18	SyncSitr	36	1	78
19	Dragnfly	36	1	79
20	Indosync	36	1	81

Plug-in Voice List/Plug-In-Stimmenliste/Liste des voix plug-in

● PLG150-PF Plug in Voice List

Category Order	Voice Name	MSB#	LSB#	MIDI Program Change#
I (Piano 1)				
1	GndPnoSt	80	0	0
2	DbI Pno	80	82	0
3	Montuno	80	83	0
4	GrndDyno	80	84	0
5	David	80	85	0
6	RhodyGnd	80	86	0
7	GrandDX	80	88	0
8	GrandDX2	80	89	0
9	Bob	80	90	0
10	PianoStr	80	91	0
II (Piano 2)				
1	GndPnoMn	80	64	0
2	FIngGrnd	80	80	0
3	BrghtGnd	80	65	0
4	60'sGrnd	80	66	0
5	RchGndSt	80	67	0
6	60'sJazz	80	69	0
7	PowerGnd	80	72	0
8	MildGrnd	80	73	0
9	ChorusMn	80	75	0
10	AmbiGrnd	80	79	0
III (Piano 3)				
1	PnoStPad	80	92	0
2	SynStrPf	80	93	0
3	PianoPad	80	94	0
4	OctPf+Pd	80	95	0
5	Pf+Choir	80	96	0
6	ModPd Pf	80	97	0
7	SitaryPf	80	99	0
8	StGndPSt	80	100	0
9	StRichSt	80	102	0
10	StTghtSt	80	104	0
IV (Piano 4)				
1	BrghtPno	80	0	1
2	Digital	80	64	1
3	ChorDigi	80	65	1
4	DigiGrnd	80	67	1
5	Grnd/wDX	80	68	1
6	ChoDigiP	80	69	1
7	GlassPno	80	70	1
8	DigiTine	80	71	1
9	SawDigi1	80	72	1
10	SawDigi2	80	73	1
V (E.Piano 1)				
1	CP	80	0	2
2	CP-Symph	80	64	2
3	Trem CP	80	65	2
4	BrightCP	80	66	2
5	Digi CP1	80	67	2
6	Jino	80	68	2
7	Digi CP2	80	69	2
8	Petit CP	80	70	2
9	Hnkytnk2	80	64	3

Category Order	Voice Name	MSB#	LSB#	MIDI Program Change#
10	Hnkytnk3	80	65	3
VI (E.Piano 2)				
1	Tea	80	0	4
2	Deodar	80	64	4
3	70's EP	80	65	4
4	80's EP	80	66	4
5	Crisp EP	80	67	4
6	Sweetnes	80	68	4
7	Freeway	80	69	4
8	Trem 70	80	70	4
9	Remark	80	71	4
10	Mid 70's	80	73	4
VII (E.Piano 3)				
1	Celest80	80	74	4
2	At Once	80	75	4
3	TremDyno	80	76	4
4	TremWurl	80	77	4
5	Phase 70	80	78	4
6	DlydDyno	80	79	4
7	FIngDyno	80	80	4
8	Dyno 81	80	82	4
9	Tonight	80	83	4
10	Dyno 83	80	84	4
VIII (E.Piano 4)				
1	Choir EP	80	87	4
2	Paddy EP	80	88	4
3	VcePd EP	80	89	4
4	60's EP	80	91	4
5	Trump	80	92	4
6	DonnyWrl	80	93	4
7	WurliAmp	80	94	4
8	Dg Wurli	80	95	4
IX (E.Piano 5)				
1	FullTine	80	0	5
2	DX EP2	80	64	5
3	DX 1990	80	66	5
4	Mllw DX	80	67	5
5	ChrsTine	80	68	5
6	Chrs EP2	80	69	5
7	Chrs1980	80	70	5
8	Chrs1990	80	71	5
9	DarkDXEP	80	72	5
10	FTBallad	80	73	5
X (E.Piano 6)				
1	Sym EP2	80	74	5
2	Chrs1982	80	75	5
3	90Ballad	80	76	5
4	816	80	77	5
5	DXEP+Pad	80	78	5
6	DXSynStr	80	79	5
7	DXEP+Cho	80	80	5
8	Balmy DX	80	81	5
9	GlassyEP	80	82	5
10	Chrs FMP	80	84	5

Plug-in Voice List/Plug-In-Stimmenliste/Liste des voix plug-in

Category Order	Voice Name	MSB#	LSB#	MIDI Program Change#
XI (Harpsi&Clavi)				
1	Harpsi 1	80	0	6
2	Harpsi 2	80	64	6
3	RichHpsi	80	67	6
4	Clav 1	80	0	7
5	Clav 2	80	64	7
6	MuteClav	80	65	7
7	Phs Clav	80	66	7
8	PhsClav2	80	67	7
9	Wah Clav	80	68	7
10	DigiClav	80	69	7
11	Ch DgClv	80	70	7
12	PhsDgClv	80	71	7

Plug-in Voice List/Plug-In-Stimmenliste/Liste des voix plug-in

● PLG150-DX Plug in Voice List

Category Order	Voice Name	MSB#	LSB#	MIDI Program Change#
I				
1	E.Pno1	35	1	1
2	DX-Road2	35	1	12
3	E.PIANO1	35	0	10
4	WurlieP1	35	1	11
5	RatioDob	35	1	8
6	CosaRosa	35	1	13
7	E.PIANO2	35	0	34
8	Knock EP	83	70	4
9	Hard EP1	83	97	4
10	Vics EP	83	68	5
11	Duke EP	83	72	5
12	DynoRoad	83	96	5
13	E.Pno 2	35	1	3
14	Bell Pno	83	69	3
15	BigWurlt	83	64	4
16	DX-Road3	83	68	4
17	EP 1970	83	71	4
18	Urban	83	66	5
19	E.Pno 4	83	69	5
20	Mark III	83	70	2
II				
1	MM-Clav1	35	1	19
2	CLAV 1	35	0	19
3	Clavecn1	83	68	7
4	MM-Clav2	83	64	7
5	CLAV 2	35	0	42
6	Skltnciv	35	1	20
7	ClavStf1	35	1	21
8	MuteClav	83	99	7
9	BritClv1	83	75	7
10	Revinett	83	67	7
11	DX-Clv 1	83	70	7
12	HARPSIC1	35	0	18
13	HyperSqr	35	1	89
14	Xanu	35	1	113
15	MM-Pretv	83	66	88
16	Gior Pad	83	66	93
17	LUTE	35	0	58
18	HARP 2	35	0	61
19	DX-Harp1	35	1	94
20	OrchHarp	83	65	46
III				
1	PIANO 2	35	0	8
2	DXCP-70	35	1	16
3	Digi Pno	83	66	0
4	5th Pno1	83	66	1
5	TOY PIAN	35	0	39
6	Glocken1	83	0	9
7	DX-Vibe1	35	1	23
8	MARIMBA	35	0	21
9	DX-Xylo2	83	64	13
10	TUB BELL	35	0	25
11	DX-Bel 1	83	64	14
12	DX-BigBn	67	0	69
13	MelwMrmb	83	103	12
14	Vibetron	83	70	11
15	Glocken4	83	66	9

Category Order	Voice Name	MSB#	LSB#	MIDI Program Change#
16	PIANO 4	35	0	32
17	PowerPno	35	1	15
18	IronEch2	67	0	71
19	MiniBell	35	1	27
20	Carillon	35	1	25
IV				
1	Gtr Box	83	71	25
2	Folknik	83	74	25
3	Tite Gtr	35	1	40
4	DX-JzGt1	83	0	26
5	DX-AcGt4	83	66	24
6	DX-PkGt3	83	65	25
7	DX-PkGt7	83	69	25
8	DX-JzGt2	83	64	26
9	DX-CIGt6	83	68	27
10	DX-CIGt9	83	96	27
11	DX-CIGt1	35	1	42
12	DX-CIGt5	35	1	43
13	GUIAR 5	35	0	56
14	GUIAR 2	35	0	12
15	KOTO	35	0	22
16	Mrmb Gtr	83	69	24
17	DX-CIGt4	83	66	27
18	DX-DsGt5	83	68	30
19	GUIAR 1	35	0	11
20	RytmPluk	83	75	25
V				
1	BASS 1	35	0	14
2	BogiBass	35	1	30
3	FustBass	83	67	33
4	DX-SyBa3	35	1	34
5	PickPluk	83	64	34
6	ChifBass	83	65	34
7	Owl Bass	83	67	34
8	FrtlsBa3	83	65	35
9	DX-SyBa5	35	1	36
10	DX-SyBa6	35	1	37
11	DX-Bass3	83	66	39
12	After 88	83	67	32
13	BASS 4	35	0	63
14	Cutmandu	35	1	35
15	BASS 3	35	0	62
16	FrtlsBa5	83	67	35
17	DX-SyBa9	83	96	38
18	MM-Fall	67	0	88
19	MM-SDr 1	35	1	119
20	DX-MtSnr	83	96	118
VI				
1	DX-Str 8	35	1	75
2	SolinePf	35	1	83
3	BellStr2	83	97	100
4	WarmStr1	83	0	49
5	Soft Bow	83	74	50
6	DX-AnSt3	83	65	51
7	Aftnoon	83	73	51
8	Str&Brs	35	1	85
9	SyBr Pd6	83	69	90
10	ORCHESTR	35	0	6

Plug-in Voice List/Plug-In-Stimmenliste/Liste des voix plug-in

Category Order	Voice Name	MSB#	LSB#	MIDI Program Change#
11	GrngePad	83	0	94
12	WarmStr4	83	68	51
13	DX-AnSt1	83	70	50
14	DX-Str10	83	66	49
15	SyBr Pd3	83	66	90
16	SyBr Pd2	83	65	90
17	DX-Str 5	83	70	48
18	DX-Str 3	83	68	48
19	Mid Str1	83	0	48
20	DX-SySt7	35	1	86
VII				
1	DX-Trpt2	83	64	56
2	DX-Trpt3	83	65	56
3	DX-Trpt4	83	66	56
4	SlvTrmpt	83	67	56
5	DX-Trb 2	83	64	57
6	BRASS 1	35	0	0
7	BRASS 2	35	0	1
8	BRASS 3	35	0	2
9	DX-BrSc2	35	1	65
10	CS80-Br1	35	1	66
11	DX-Tuba2	83	64	58
12	AlpsHorn	83	68	60
13	DX-Horn	83	0	60
14	MelwHrn1	83	64	60
15	MletHorn	83	66	60
16	BlrchHrn	83	67	60
17	BrsLead1	83	0	83
18	BrsLead2	83	65	83
19	BrsLead3	83	66	83
20	ChorsBrs	83	0	63
VIII				
1	Court	83	79	62
2	DX-BrSc1	83	0	61
3	DX-SBr 2	35	1	68
4	DX-SBr 3	83	67	62
5	DX-SBr 5	83	69	62
6	DX-SBr 6	83	70	62
7	DX-SBr 7	83	65	63
8	Ensemble	83	71	63
9	Fanfare	83	72	61
10	HardBrss	83	96	61
11	Horn Ens	83	71	61
12	Juice	83	80	62
13	MM-Brss1	35	1	69
14	MM-Brss2	35	1	70
15	MM-Brss3	83	73	62
16	SinglBrs	83	67	63
17	SynHorns	35	1	74
18	TightBr1	83	66	61
19	TightBr2	83	67	61
20	WarmBrss	83	70	61
IX				
1	FLUTE 1	35	0	23
2	Quena	83	65	76
3	Harvest	35	1	96
4	CaliopL3	83	66	82
5	DX-Ocrn2	83	64	79

Category Order	Voice Name	MSB#	LSB#	MIDI Program Change#
6	VbrtClar	83	0	71
7	DX-Clar1	83	65	71
8	Oboe 1	83	0	68
9	Au Campo	83	0	84
10	Bassoon	83	0	70
11	DX-Acrd4	35	1	61
12	DX-Flt 3	83	65	73
13	DX-Botle	83	64	76
14	Whistle1	83	0	78
15	DX-Ocrn1	83	0	79
16	CaliopL2	83	64	82
17	DrwOrg11	35	1	46
18	PufOrgn2	83	65	20
19	PIPES 1	35	0	17
20	DXChrch2	35	1	58
X				
1	E.ORGAN1	35	0	16
2	E.ORGAN4	35	0	46
3	JazOrg 1	83	67	16
4	DrwOrg 5	83	70	16
5	DrwOrg15	35	1	48
6	PrcOrg 4	35	1	51
7	RckOrg 4	83	66	18
8	RckOrg14	83	97	18
9	Whisper1	83	65	91
10	ArrowxMS	35	1	102
11	Janpany	35	1	118
12	Fixatone	35	1	124
13	Laser 2	35	1	125
14	DX-Ring1	67	0	64
15	DX-Echo1	83	102	102
16	DX-Aggo1	83	0	113
17	Block	83	0	115
18	Log Drum	83	96	115
19	SoftHead	83	64	116
20	CongaDrm	83	96	116
XI				
1	Ana Poly	83	78	62
2	AnalogBr	83	97	62
3	SYN-LEA1	35	0	13
4	Super DX	83	66	81
5	DXSyLd 5	83	68	81
6	DXSyLd 9	83	99	81
7	LeadLine	83	0	87
8	SoftLd 1	35	1	103
9	DX-SLd 2	83	65	80
10	SnglLine	35	1	105
11	DX-SLd 7	35	1	99
12	Funkrhyt	35	1	71
13	PowerDrv	83	75	62
14	DX-SLd 3	83	67	80
15	DXSyLd 3	83	65	81
16	LeadPhon	83	64	84
17	WhaserPd	83	75	90
18	DX-Atms2	83	67	99
19	DX-MtPd1	35	1	92
20	TrcrBell	35	1	116

Style List/Style-Liste/Liste des styles

● Preset Style/Stil Voreinstellung/Style présélectionné

Category Order	Style Name	Category Order	Style Name
8 BEAT			
1	Heart Beat	4	Rock & Roll
2	8 Beat 1	5	Croco Twist
3	8 Beat 2	6	Gospel Brothers
4	8 Beat 3	7	Gospel Sisters
5	8 Beat 4	8	Gospel Shuffle
6	6/8 Slow Rock	9	6/8 Blues
7	Spicy Beat	10	Boogie Woogie 1
8	8 Beat Adria	11	Amazing Gospel
9	Off Beat	12	Blueberry Blues
10	8 Beat Rock 1	13	60's Rock & Roll
11	Piano Ballad	14	Funky Fusion
12	Guitar Ballad	15	Rock Shuffle
13	Organ Ballad	COUNTRY	
14	Love Song	1	Country Rock
15	8 Beat Ballad 1	2	Country 2/4
16	Acoustic Ballad	3	Country Swing 1
17	Modern 6/8	4	Country Shuffle 1
18	Root Rock 1	5	Country Ballad
19	Soft Rock	6	Country Waltz
20	Hard Rock	7	Bluegrass 1
16 BEAT			
1	16 Beat 1	8	Hoedown
2	16 Beat 2	9	Country Brothers
3	16 Beat 3	10	Guitar Pop
4	16 Beat 4	LATIN	
5	Slow & Easy	1	Samba City
6	Smooth Jazz	2	Samba Rio
7	Uptown Beat	3	Bossa Nova
8	Jazz Rock	4	Fast Bossa
9	Kool Shuffle	5	Mambo 1
10	West End Shuffle	6	Caribbean
DANCE			
1	House Musik	7	Carnival
2	DJ Berlin	8	Gypsy Rumba
3	Trance 1	9	Pop Rumba
4	Hip Hop	10	Sheriff Reggae
5	Trip Hop	MARCH&WALTZ	
6	Disco Chocolate	1	US March
7	70's Disco 1	2	German March 1
8	Saturday Night	3	6/8 March
9	Disco Fox	4	Polka Oberkrainer
10	Techno-Polis	5	Waltz Oberkrainer
11	Euro Shop	6	Guitar Serenade
12	Entrance	7	Tarantella 1
13	Clubdance	8	Polka Pop 1
14	Flip Hop	9	Jazz Waltz
15	Disco Samba	10	Slow Waltz
SWING&JAZZ			
1	Big Band 1	BALLROOM	
2	Big Band 2	1	Viennese Waltz
3	Big Band 3	2	English Waltz
4	Swing 1	3	Slowfox 1
5	Swing 2	4	Quickstep
6	Acoustic Jazz	5	Tango
7	Electric Jazz	6	Samba
8	Jazz Ballad 1	7	Rumba
9	Gypsy Swing	8	Cha Cha Cha
10	Swingfox	9	Pasodoble 1
11	Dixieland	10	Jive
12	Ragtime	11	Metronome 1/4
13	Big Band Ballad	12	Metronome 2/4
14	Shuffle	13	Metronome 3/4
15	Piano Swing	14	Metronome 4/4
R&B			
1	Soul Shuffle	15	Metronome 6/8
2	Soul	16	Bass Chord Hold 1
3	Modern R&B	17	Bass Chord Hold 2
		18	Bass Chord Hold 3
		19	Bass Chord Hold 4
		20	Bass Chord Hold 5

● Flash Style/Stil Blitz/Style Flash

Category Order	Style Name	Category Order	Style Name
I (8 BEAT)			
1	60's Rock 1	5	Country 8 Beat 1
2	60's Rock 2	6	Country Pop
3	8 Beat 5	7	Country Swing 2
4	8 Beat Rock 2	8	Cowboy Boogie
5	8 Beat Rock 3	9	Cowboy Rock
6	8 Beat Ballad 2	10	Singer Song Writer
7	Barock	VII (LATIN)	
8	Root Rock 2	1	Espagnole
9	Root Rock 3	2	Rumba Flamenca
10	Slow Rock	3	Salsa
II (16 BEAT)			
1	Uptown Shuffle	4	Rumba Island
2	LA Groove	5	Piano Rumba
3	Funk	7	Beguine
4	Analog Ballad	8	Guitar Bossa
5	Hip Hop Pop	9	Bossa Band
6	16Beat Ballad 1	10	Happy Reggae
7	16Beat Ballad 2	11	Jumbo Reggae
8	EP Ballad	VIII (MARCH&WALTZ)	
9	Pop Ballad	1	Showtune
10	16Beat Rock Ballad	2	Polka Pop 2
III (DANCE)			
1	6/8 Trance	3	German March 2
2	16Beat Dance Shuffle	4	Jig
3	70's Disco 2	5	Reel
4	Dance Funk	6	Musette
5	Dance Soul	7	Swing Waltz
6	Disco	8	Pop Waltz
7	Disco Fusion	9	Christmas 3/4
8	Disco Hands	10	Christmas 4/4
9	Eurobeat		
10	Groundbeat		
11	Handbag		
12	Party Pop		
13	Soul Dance		
14	Techno1		
15	Trance 2		
IV (SWING&JAZZ)			
1	Bebop		
2	Big Band Shuffle		
3	Cat Groove		
4	Foxtrot 1		
5	Foxtrot 2		
6	Jazz Ballad 2		
7	Lounge Piano		
8	Midnight Swing		
9	Miller Ballad		
10	Organ Quickstep		
11	Vocal Swing		
12	Jazz Singer		
V (R&B)			
1	16 Beat Funk		
2	60's Rock 3		
3	Blues Shuffle		
4	Boogie Woogie 2		
5	Lovely Shuffle		
6	Motown		
7	Motown Soul		
8	Soul Beat		
9	Pop Shuffle		
10	Twist		
VI (COUNTRY)			
1	Bluegrass 2		
2	Carpenter		
3	Country Two Step		
4	Country 8 Beat 2		

Multi Pad Bank List/Multi-Pad-Bankliste/Liste des banques multi-pads

Bank Number	Bank Name
1	Live! Tom
2	Live! Crash
3	Live! Kit 1
4	Live! Kit 2
5	Live! Kit 3
6	ArabicPerc 1
7	ArabicPerc 2
8	Live! Perc 1
9	Live! Perc 2
10	Dance Kit
11	Scat 1
12	Scat 2
13	Scat 3
14	Scat 4
15	Swingy
16	Live! Brass 1
17	Live! Brass 2
18	SynBrass
19	Mallet Fills
20	Piano Man
21	Heaven Arp
22	Piano Arp
23	Harpeggio 1
24	Harpeggio 2
25	Arpeggio
26	Crystal Arp
27	Twinkle Arp
28	Piano Gliss
29	Xmas 1
30	Xmas 2
31	Attention 1
32	Attention 2
33	Fanfare 1
34	Fanfare 2
35	Classical
36	Flamenco Gtr
37	Salsa Piano
38	Samba Show 1
39	Samba Show 2
40	TimbalesRoll
41	Guitar Cut 1
42	Guitar Cut 2
43	GuitarRiff 1
44	GuitarRiff 2
45	Guitar Strum
46	LiveDrumFill
47	Limbo Dancer
48	DJ Set 1

Bank Number	Bank Name
49	DJ Set 2
50	OrchestraHit
51	Water SE
52	Horror SE
53	Night SE
54	Day SE
55	Car SE
56	Big Bells
57	Whistle
58	MagicBell SE
59	MIDI Control
60	Scale Tune

Parameter Chart/Parameter-Tabelle/

o : Memorized
 x : Not memorized
 ON : Always ON when the corresponding function is called up.

o : Wird gespeichert
 x : Wird nicht gespeichert
 ON Ist immer eingeschaltet, wenn die zugehörige Funktion aufgerufen wird.

o : mémorisé
 x : non mémorisé
 ON : toujours activé lorsque la fonction correspondante est appelée

	One Touch Setting	Music Database	Registration Memory	Setup (Disk)	System Backup	VoiceSet Group	Freeze Group	Parameter Lock
Auto Accompaniment								
Style #	x	o	o	o	o	x	Acmp.	x
Auto Acmpaniment ON/OFF	ON	o	o	o	o	x	Acmp.	x
Fingering	x	x	o	o	o	x	Acmp.	Fingering
Split Point	x	x	o	o	o	x	Acmp.	Split Point
Main Variation [MainA/B/C/D]	x	o	o	x	x	x	Acmp.	x
FADE IN/OUT	x	x	x	x	x	x	x	x
FILL In & Break Mode	x	x	x	x	x	x	x	x
Tap Tempo	x	x	x	x	x	x	x	x
Tap Count Note	o	o	o	o	o	x	Acmp.	x
Tap Count Velocity	o	o	o	o	o	x	Acmp.	x
Acmp. Main Volume	x	o	o	x	x	x	Acmp.	x
Acmp. Main EQ Low	x	x	o	x	x	x	Acmp.	x
Acmp. Main EQ High	x	x	o	x	x	x	Acmp.	x
Acmp. Main Panpot	x	x	o	x	x	x	Acmp.	x
Acmp. Main Reverb Depth	x	x	o	x	x	x	Acmp.	x
Acmp. Main Chorus Depth	x	x	o	x	x	x	Acmp.	x
Acmp. Main DSP Depth	x	x	o	x	x	x	Acmp.	x
Acmp. Rhythm 1 Part Track On/Off	x	o	o	x	x	x	Acmp.	x
Acmp. Rhythm 2 Part Track On/Off	x	o	o	x	x	x	Acmp.	x
Acmp. Bass Part Track On/Off	x	o	o	x	x	x	Acmp.	x
Acmp. Chord 1 Part Track On/Off	x	o	o	x	x	x	Acmp.	x
Acmp. Chord 2 Part Track On/Off	x	o	o	x	x	x	Acmp.	x
Acmp. Pad Part Track On/Off	x	o	o	x	x	x	Acmp.	x
Acmp. Phrase 1 Part Track On/Off	x	o	o	x	x	x	Acmp.	x
Acmp. Phrase 2 Part Track On/Off	x	o	o	x	x	x	Acmp.	x
Acmp. Rhythm 1 Part Volume	x	o	o	x	x	x	Acmp.	x
Acmp. Rhythm 2 Part Volume	x	o	o	x	x	x	Acmp.	x
Acmp. Bass Part Volume	x	o	o	x	x	x	Acmp.	x
Acmp. Chord 1 Part Volume	x	o	o	x	x	x	Acmp.	x
Acmp. Chord 2 Part Volume	x	o	o	x	x	x	Acmp.	x
Acmp. Pad Part Volume	x	o	o	x	x	x	Acmp.	x
Acmp. Phrase 1 Part Volume	x	o	o	x	x	x	Acmp.	x
Acmp. Phrase 2 Part Volume	x	o	o	x	x	x	Acmp.	x
Acmp. Rhythm 1 Part Panpot	x	o	o	x	x	x	Acmp.	x
Acmp. Rhythm 2 Part Panpot	x	o	o	x	x	x	Acmp.	x
Acmp. Bass Part Panpot	x	o	o	x	x	x	Acmp.	x
Acmp. Chord 1 Part Panpot	x	o	o	x	x	x	Acmp.	x
Acmp. Chord 2 Part Panpot	x	o	o	x	x	x	Acmp.	x

	One Touch Setting	Music Database	Registration Memory	Setup (Disk)	System Backup	VoiceSet Group	Freeze Group	Parameter Lock
Acmp. Pad Part Panpot	x	o	o	x	x	x	Acmp.	x
Acmp. Phrase 1 Part Panpot	x	o	o	x	x	x	Acmp.	x
Acmp. Phrase 2 Part Panpot	x	o	o	x	x	x	Acmp.	x
Acmp. Rhythm 1 Part Reverb Depth	x	o	o	x	x	x	Acmp.	x
Acmp. Rhythm 2 Part Reverb Depth	x	o	o	x	x	x	Acmp.	x
Acmp. Bass Part Reverb Depth	x	o	o	x	x	x	Acmp.	x
Acmp. Chord 1 Part Reverb Depth	x	o	o	x	x	x	Acmp.	x
Acmp. Chord 2 Part Reverb Depth	x	o	o	x	x	x	Acmp.	x
Acmp. Pad Part Reverb Depth	x	o	o	x	x	x	Acmp.	x
Acmp. Phrase 1 Part Reverb Depth	x	o	o	x	x	x	Acmp.	x
Acmp. Phrase 2 Part Reverb Depth	x	o	o	x	x	x	Acmp.	x
Acmp. Rhythm 1 Part Chorus Depth	x	o	o	x	x	x	Acmp.	x
Acmp. Rhythm 2 Part Chorus Depth	x	o	o	x	x	x	Acmp.	x
Acmp. Bass Part Chorus Depth	x	o	o	x	x	x	Acmp.	x
Acmp. Chord 1 Part Chorus Depth	x	o	o	x	x	x	Acmp.	x
Acmp. Chord 2 Part Chorus Depth	x	o	o	x	x	x	Acmp.	x
Acmp. Pad Part Chorus Depth	x	o	o	x	x	x	Acmp.	x
Acmp. Phrase 1 Part Chorus Depth	x	o	o	x	x	x	Acmp.	x
Acmp. Phrase 2 Part Chorus Depth	x	o	o	x	x	x	Acmp.	x
Acmp. Rhythm 1 Part Variation (DSP3) Depth	x	o	o	x	x	x	Acmp.	x
Acmp. Rhythm 2 Part Variation (DSP3) Depth	x	o	o	x	x	x	Acmp.	x
Acmp. Bass Part Variation (DSP3) Depth	x	o	o	x	x	x	Acmp.	x
Acmp. Chord 1 Part Variation (DSP3) Depth	x	o	o	x	x	x	Acmp.	x
Acmp. Chord 2 Part Variation (DSP3) Depth	x	o	o	x	x	x	Acmp.	x
Acmp. Pad Part Variation (DSP3) Depth	x	o	o	x	x	x	Acmp.	x
Acmp. Phrase 1 Part Variation (DSP3) Depth	x	o	o	x	x	x	Acmp.	x
Acmp. Phrase 2 Part Variation (DSP3) Depth	x	o	o	x	x	x	Acmp.	x
Acmp. Rhythm 1 Part Voice Change Voice #	x	o	o	x	x	x	Acmp.	x
Acmp. Rhythm 2 Part Voice Change Voice #	x	o	o	x	x	x	Acmp.	x
Acmp. Bass Part Voice Change Voice #	x	o	o	x	x	x	Acmp.	x
Acmp. Chord 1 Part Voice Change Voice #	x	o	o	x	x	x	Acmp.	x
Acmp. Chord 2 Part Voice Change Voice #	x	o	o	x	x	x	Acmp.	x
Acmp. Pad Part Voice Change Voice #	x	o	o	x	x	x	Acmp.	x
Acmp. Phrase 1 Part Voice Change Voice #	x	o	o	x	x	x	Acmp.	x
Acmp. Phrase 2 Part Voice Change Voice #	x	o	o	x	x	x	Acmp.	x
Acmp. Rhythm 1 Part Harmonic Content	x	o	o	x	x	x	Acmp.	x

Tableau des paramètres

	One Touch Setting	Music Database	Registration Memory	Setup (Disk)	System Backup	VoiceSet Group	Freeze Group	Parameter Lock
Acmp. Rhythm 2 Part Harmonic Content	x	o	o	x	x	x	Acmp.	x
Acmp. Bass Part Harmonic Content	x	o	o	x	x	x	Acmp.	x
Acmp. Chord 1 Part Harmonic Content	x	o	o	x	x	x	Acmp.	x
Acmp. Chord 2 Part Harmonic Content	x	o	o	x	x	x	Acmp.	x
Acmp. Pad Part Harmonic Content	x	o	o	x	x	x	Acmp.	x
Acmp. Phrase 1 Part Harmonic Content	x	o	o	x	x	x	Acmp.	x
Acmp. Phrase 2 Part Harmonic Content	x	o	o	x	x	x	Acmp.	x
Acmp. Rhythm 1 Part Brightness	x	o	o	x	x	x	Acmp.	x
Acmp. Rhythm 2 Part Brightness	x	o	o	x	x	x	Acmp.	x
Acmp. Bass Part Brightness	x	o	o	x	x	x	Acmp.	x
Acmp. Chord 1 Part Brightness	x	o	o	x	x	x	Acmp.	x
Acmp. Chord 2 Part Brightness	x	o	o	x	x	x	Acmp.	x
Acmp. Pad Part Brightness	x	o	o	x	x	x	Acmp.	x
Acmp. Phrase 1 Part Brightness	x	o	o	x	x	x	Acmp.	x
Acmp. Phrase 2 Part Brightness	x	o	o	x	x	x	Acmp.	x
Acmp. Rhythm 1 Part EQ Low	x	o	o	x	x	x	Acmp.	x
Acmp. Rhythm 2 Part EQ Low	x	o	o	x	x	x	Acmp.	x
Acmp. Bass Part EQ Low	x	o	o	x	x	x	Acmp.	x
Acmp. Chord 1 Part EQ Low	x	o	o	x	x	x	Acmp.	x
Acmp. Chord 2 Part EQ Low	x	o	o	x	x	x	Acmp.	x
Acmp. Pad Part EQ Low	x	o	o	x	x	x	Acmp.	x
Acmp. Phrase 1 Part EQ Low	x	o	o	x	x	x	Acmp.	x
Acmp. Phrase 2 Part EQ Low	x	o	o	x	x	x	Acmp.	x
Acmp. Rhythm 1 Part EQ High	x	o	o	x	x	x	Acmp.	x
Acmp. Rhythm 2 Part EQ High	x	o	o	x	x	x	Acmp.	x
Acmp. Bass Part EQ High	x	o	o	x	x	x	Acmp.	x
Acmp. Chord 1 Part EQ High	x	o	o	x	x	x	Acmp.	x
Acmp. Chord 2 Part EQ High	x	o	o	x	x	x	Acmp.	x
Acmp. Pad Part EQ High	x	o	o	x	x	x	Acmp.	x
Acmp. Phrase 1 Part EQ High	x	o	o	x	x	x	Acmp.	x
Acmp. Phrase 2 Part EQ High	x	o	o	x	x	x	Acmp.	x
Synchro Stop	x	x	x	x	x	x	x	x
Synchro Start	ON	o	x	x	x	x	x	x
Start/Stop	x	x	x	x	x	x	x	x
Song								
Song On/Off	x	x	o	x	x	x	Song	x
Lyrics Search On/Off	x	x	o	o	o	x	Song	x
Ultra Quick Start On/Off	x	x	o	o	o	x	Song	x
Song Full Path (Including the file name for the Registration Memory)	x	x	o	x	x	x	Song	x
Song Full Path (Not including the file name for the Backup)	x	x	x	o	o	x	Song	x
Song Select (Song #)	x	x	x	x	x	x	x	x

	One Touch Setting	Music Database	Registration Memory	Setup (Disk)	System Backup	VoiceSet Group	Freeze Group	Parameter Lock
Song Name	x	x	x	x	x	x	x	x
Song Pause/Rew/FF	x	x	x	x	x	x	x	x
Song Volume	x	x	o	x	x	x	x	x
Song EQ Low	x	x	x	x	x	x	x	x
Song EQ High	x	x	x	x	x	x	x	x
Song Panpot	x	x	x	x	x	x	x	x
Song Reverb Depth	x	x	x	x	x	x	x	x
Song Chorus Depth	x	x	x	x	x	x	x	x
Song Variation (DSP3) Depth	x	x	x	x	x	x	x	x
Song Track Solo/Mute/Play (Track1~16)	x	x	x	x	x	x	x	x
Song Track Volume (Track1~16)	x	x	x	x	x	x	x	x
Song Track Panpot (Track1 ~16)	x	x	x	x	x	x	x	x
Song Track EQ Low (Track1~16)	x	x	x	x	x	x	x	x
Song Track EQ High (Track1~16)	x	x	x	x	x	x	x	x
Song Track Reverb Depth (Track1~16)	x	x	x	x	x	x	x	x
Song Track Chorus Depth (Track1~16)	x	x	x	x	x	x	x	x
Song Track Variation (DSP3) Depth (Track1~16)	x	x	x	x	x	x	x	x
Song Track Program Change #	x	x	x	x	x	x	x	x
Song Part Harmonic Content (Track1~16)	x	x	x	x	x	x	x	x
Song Part Brightness (Track1~16)	x	x	x	x	x	x	x	x
Voice								
Part Select (Left/Right1/Right2/Right3)	x	x	x	x	x	x	x	x
Upper Octave	o	o	o	x	x	x	Voice	x
Sustain SW (R1/R2/R3) ON/OFF	x	x	o	x	x	x	Voice	x
Touch SW ON/OFF	x	x	o	x	x	x	voice	x
Right 1 Part On/Off	o	o	o	x	x	x	Voice	x
Right 1 Voice #	o	o	o	x	x	x	Voice	x
Right 1 Release Time (Bn 48h)	x	x	x	x	x	Voice	x	x
Right 1 Voice Octave	o	o	o	x	x	Voice	Voice	x
Right 1 Part Volume	o	o	o	x	x	x	Voice	x
Right 1 Part Panpot	o	o	o	x	x	x	Voice	x
Right 1 Reverb Depth	o	o	o	x	x	Effects	Voice	x
Right 1 Chorus Depth	o	o	o	x	x	Effects	Voice	x
Right 1 Poly/Mono ON/OFF	o	o	o	x	x	Voice	Voice	x
Right1 Portamento (Poly/Mono)	o	o	o	x	x	x	Voice	x
Right1 Tuning	o	o	o	x	x	x	Voice	x
Right1 Pitch Bend Range	o	o	o	x	x	x	Voice	x
Right1 Portamento Time	o	o	o	x	x	Voice	Voice	x
Right1 Harmonic Content	o	o	o	x	x	Voice	Voice	x
Right1 Brightness	o	o	o	x	x	Voice	Voice	x
Right1 EQ Low	o	o	o	x	x	EQ	Voice	x

Parameter Chart/Parameter-Tabelle/Tableau des paramètres

	One Touch Setting	Music Database	Registration Memory	Setup (Disk)	System Backup	VoiceSet Group	Freeze Group	Parameter Lock
Right1 EQ High	o	o	o	x	x	EQ	Voice	x
Right 2 Part On/Off	o	o	o	x	x	x	Voice	x
Right 2 Voice #	o	o	o	x	x	x	Voice	x
Right 2 Release Time (Bn 48h)	x	x	x	x	x	Voice	x	x
Right 2 Voice Octave	o	o	o	x	x	Voice	Voice	x
Right 2 Part Volume	o	o	o	x	x	x	Voice	x
Right 2 Part Panpot	o	o	o	x	x	x	Voice	x
Right 2 Reverb Depth	o	o	o	x	x	Effects	Voice	x
Right 2 Chorus Depth	o	o	o	x	x	Effects	Voice	x
Right 2 Poly/Mono ON/OFF	o	o	o	x	x	Voice	Voice	x
Right 2 Portamento (Poly/Mono)	o	o	o	x	x	x	Voice	x
Right 2 Tuning	o	o	o	x	x	x	Voice	x
Right 2 Pitch Bend Range	o	o	o	x	x	x	Voice	x
Right 2 Portamento Time	o	o	o	x	x	Voice	Voice	x
Right 2 Harmonic Content	o	o	o	x	x	Voice	Voice	x
Right 2 Brightness	o	o	o	x	x	Voice	Voice	x
Right 2 EQ Low	o	o	o	x	x	EQ	Voice	x
Right 2 EQ High	o	o	o	x	x	EQ	Voice	x
Right 3 (LEAD) Part On/Off	o	o	o	x	x	x	Voice	x
Right 3 Voice #	o	o	o	x	x	x	Voice	x
Right 3 Release Time (Bn 48h)	x	x	x	x	x	Voice	x	x
Right 3 Voice Octave	o	o	o	x	x	Voice	Voice	x
Right 3 Part Volume	o	o	o	x	x	x	Voice	x
Right 3 Part Panpot	o	o	o	x	x	x	Voice	x
Right 3 Reverb Depth	o	o	o	x	x	Effects	Voice	x
Right 3 Chorus Depth	o	o	o	x	x	Effects	Voice	x
Right 3 Poly/Mono ON/OFF	o	o	o	x	x	Voice	Voice	x
Right 3 Portamento (Poly/Mono)	o	o	o	x	x	x	Voice	x
Right 3 Tuning	o	o	o	x	x	x	Voice	x
Right 3 Pitch Bend Range	o	o	o	x	x	x	Voice	x
Right 3 Portamento Time	o	o	o	x	x	Voice	Voice	x
Right 3 Harmonic Content	o	o	o	x	x	Voice	Voice	x
Right 3 Brightness	o	o	o	x	x	Voice	Voice	x
Right 3 EQ Low	o	o	o	x	x	EQ	Voice	x
Right 3 EQ High	o	o	o	x	x	EQ	Voice	x
Left Part On/Off	o	o	o	x	x	x	Acmp.	x
Left Voice #	o	o	o	x	x	x	Acmp.	x
Left Voice Octave	o	o	o	x	x	Voice	Acmp.	x
Left Part Volume	o	o	o	x	x	x	Acmp.	x
Left Part Panpot	o	o	o	x	x	x	Acmp.	x
Left Reverb Depth	o	o	o	x	x	Effects	Acmp.	x

	One Touch Setting	Music Database	Registration Memory	Setup (Disk)	System Backup	VoiceSet Group	Freeze Group	Parameter Lock
Left Chorus Depth	o	o	o	x	x	Effects	Acmp.	x
Left Poly/Mono ON/OFF	o	o	o	x	x	Voice	Acmp.	x
Left Portamento (Poly/Mono)	o	o	o	x	x	x	Acmp.	x
Left Tuning	o	o	o	x	x	x	Acmp.	x
Left Pitch Bend Range	o	o	o	x	x	x	Acmp.	x
Left Portamento Time	o	o	o	x	x	Voice	Acmp.	x
Left Harmonic Content	o	o	o	x	x	Voice	Acmp.	x
Left Brightness	o	o	o	x	x	Voice	Acmp.	x
Left EQ Low	o	o	o	x	x	EQ	Acmp.	x
Left EQ High	o	o	o	x	x	EQ	Acmp.	x
Left Hold	o	o	o	x	x	x	Acmp.	x
Organ Flutes								
R1 OrganFlute Panel Organ No.	o	o	o	x	x	x	Voice	x
R2 OrganFlute Panel Organ No.	o	o	o	x	x	x	Voice	x
R3 OrganFlute Panel Organ No.	o	o	o	x	x	x	Voice	x
LEFT OrganFlute Panel Organ No.	o	o	o	x	x	x	Acmp.	x
Plug-in Voice								
R1 OrganFlute Panel Organ No.	o	o	o	x	x	x	Voice	x
R2 OrganFlute Panel Organ No.	o	o	o	x	x	x	Voice	x
R3 OrganFlute Panel Organ No.	o	o	o	x	x	x	Voice	x
LEFT OrganFlute Panel Organ No.	o	o	o	x	x	x	Acmp.	x
Effect								
Reverb Effect Type	x	o	o	x	x	x	Acmp.	Reverb Type
Reverb Effect Parameter	x	x	x	x	x	x	x	x
Reverb Return Level	x	x	o	x	x	x	Acmp.	Reverb Return Level
Chorus Effect Type	x	o	o	x	x	x	Acmp.	x
Chorus Effect Parameter	x	x	x	x	x	x	x	x
Chorus Return Level	x	x	o	x	x	x	Acmp.	Chorus Return Level
Variation (DSP3) Type	x	x	x	x	x	x	x	x
Variation (DSP3) Effect parameter	x	x	x	x	x	x	x	x
Variation (DSP3) Connection	x	x	x	x	x	x	x	x
Variation (DSP3) Part	x	x	x	x	x	x	x	x
Variation (DSP3) Return Level	x	x	x	x	x	x	x	DSP3 Return Level
Ins1. (DSP4) On/Off	o	o	o	x	x	Effects	Voice	x
Ins1. (DSP4) Insertion Type	o	o	o	x	x	Effects	Voice	x
Ins1. (DSP4). Effect parameter	x	x	x	x	x	x	x	x
Ins1. (DSP4) Fast/Slow Sw	o	o	o	x	x	Effects	Voice	x

Parameter Chart/Parameter-Tabelle/Tableau des paramètres

	One Touch Setting	Music Database	Registration Memory	Setup (Disk)	System Backup	VoiceSet Group	Freeze Group	Parameter Lock
Ins1. (DSP4) Dry/Wet	o	o	o	x	x	Effects	Voice	x
Ins1. (DSP4) Fast/Slow Effect Parameter Value	x	x	x	x	x	x	x	x
Ins2. (DSP5) On/Off	o	o	o	x	x	Effects	Voice	x
Ins2. (DSP5) Insertion Type	o	o	o	x	x	Effects	Voice	x
Ins2. (DSP5) Effect Parameter	x	x	x	x	x	x	x	x
Ins2. (DSP5) Fast/Slow	o	o	o	x	x	Effects	Voice	x
Ins2. (DSP5) Dry/Wet	o	o	o	x	x	Effects	Voice	x
Ins2. (DSP5) Fast/Slow Variation Effect Parameter Value	x	x	x	x	x	x	x	x
Ins3. (DSP6) On/Off	o	o	o	x	x	Effects	Voice	x
Ins3. (DSP6) Insertion Type	o	o	o	x	x	Effects	Voice	x
Ins3. (DSP6) Effect Parameter	x	x	x	x	x	x	x	x
Ins3. (DSP6) Fast/Slow	o	o	o	x	x	Effects	Voice	x
Ins3. (DSP6) Dry/Wet	o	o	o	x	x	Effects	Voice	x
Ins3. (DSP6) Fast/Slow Variation Effect Parameter Value	x	x	x	x	x	x	x	x
Ins4. (DSP7) On/Off	o	o	o	x	x	Effects	Acmp.	-
Ins4. (DSP7) Insertion Type	o	o	o	x	x	Effects	Acmp.	x
Ins4. (DSP7) Effect Parameter	x	x	x	x	x	x	x	x
Ins4. (DSP7) Fast/Slow	o	o	o	x	x	Effects	Acmp.	x
Ins4. (DSP7) Dry/Wet	o	o	o	x	x	Effects	Acmp.	x
Ins4. (DSP7) Fast/Slow Variation Effect Parameter Value	x	x	x	x	x	x	x	x
Ins5. (DSP8) On/Off	x	x	o	x	x	x	Mic	Mic Setting
Ins5. (DSP8) Insertion Type	x	x	o	o	o	x	Mic	Mic Setting
Ins5. (DSP8) Effect Parameter	x	x	x	x	x	x	x	Mic Setting
Ins5. (DSP8) Dry/Wet (Mic Depth)	x	x	o	o	o	x	Mic	Mic Setting
Sampling DSP1 On/Off	x	x	x	x	x	x	x	x
Sampling DSP1 Insertion Type	x	x	x	o	o	x	x	x
Sampling DSP1 Effect Parameter	x	x	x	x	x	x	x	x
Sampling DSP1 Fast/Slow	x	x	x	x	x	x	x	x
Sampling DSP1 Dry/Wet	x	x	x	x	x	x	x	x
Sampling DSP2 On/Off	x	x	x	x	x	x	x	x
Sampling DSP2 Insertion Type	x	x	x	o	o	x	x	x
Sampling DSP2 Effect parameter	x	x	x	x	x	x	x	x
Sampling DSP2 Fast/Slow	x	x	x	x	x	x	x	x
Sampling DSP2 Dry/Wet	x	x	x	x	x	x	x	x
Sampling DSP3 On/Off	x	x	x	x	x	x	x	x
Sampling DSP3 Insertion Type	x	x	x	o	o	x	x	x
Sampling DSP3 Effect Parameter	x	x	x	x	x	x	x	x
Sampling DSP3 Fast/Slow	x	x	x	x	x	x	x	x

	One Touch Setting	Music Database	Registration Memory	Setup (Disk)	System Backup	VoiceSet Group	Freeze Group	Parameter Lock
Sampling DSP3 Dry/Wet	x	x	x	x	x	x	x	x
Microphone								
Mic Volume	x	x	x	x	x	x	x	Mic Setting
Mic Panpot	x	x	o	x	x	x	Mic	Mic Setting
Mic Reverb Depth	x	x	o	x	x	x	Mic	Mic Setting
Mic Chorus Depth	x	x	o	x	x	x	Mic	Mic Setting
Mic EQ LOW Freq	x	x	x	o	o	x	x	x
Mic EQ LOW Gain	x	x	x	o	o	x	x	x
Mic EQ MID Freq	x	x	x	o	o	x	x	x
Mic EQ MID Gain	x	x	x	o	o	x	x	x
Mic EQ HIGH Freq	x	x	x	o	o	x	x	x
Mic EQ HIGH Gain	x	x	x	o	o	x	x	x
Noise Gate SW	x	x	x	o	o	x	x	x
Noise Gate TH	x	x	x	o	o	x	x	x
Compressor SW	x	x	x	o	o	x	x	x
Compressor TH	x	x	x	o	o	x	x	x
Compressor RAT	x	x	x	o	o	x	x	x
Compressor OUT	x	x	x	o	o	x	x	x
Mic Mute	x	x	x	x	x	x	x	x
Vocal Harmony Mute (Song Track)	x	x	o	x	x	x	Mic	Mic Setting
Vocal Harmony Track	x	x	o	x	x	x	Mic	Mic Setting
Vocal Harmony BAL.	x	x	o	x	x	x	Mic	Mic Setting
Vocal Harmony Part	x	x	o	x	x	x	Mic	Mic Setting
Vocal Harmony MODE	x	x	o	x	x	x	Mic	Mic Setting
Vocal Harmony Chord Detect	x	x	o	x	x	x	Mic	Mic Setting
Vocal Harmony On/Off	x	x	o	x	x	x	Mic	Mic Setting
Talk On/Off	x	x	x	x	x	x	x	x
Vocal Harmony Type	x	x	o	o	o	x	Mic	Mic Setting
Vocal Harmony Effect Parameter (Harmony Volume1/2)	x	x	x	x	x	x	x	Mic Setting
Vocal Harmony Effect Parameter (Harmony Panpot1/2)	x	x	x	x	x	x	x	Mic Setting
Vocal Harmony Effect Parameter (Harmony Detune 1/2)	x	x	x	x	x	x	x	Mic Setting
Vocal Harmony Effect Parameter (Harmony Pitch To Note)	x	x	x	x	x	x	x	Mic Setting
Vocal Harmony Effect Parameter (Harmony Pitch To Note Part)	x	x	x	x	x	x	x	Mic Setting
Vocal Harmony Gender Type	x	x	x	x	x	x	x	Mic Setting

Parameter Chart/Parameter-Tabelle/Tableau des paramètres

	One Touch Setting	Music Database	Registration Memory	Setup (Disk)	System Backup	VoiceSet Group	Freeze Group	Parameter Lock
Vocal Harmony Pitch Correction	x	x	x	x	x	x	x	Mic Setting
Vocal Harmony Harmony Part	x	x	x	x	x	x	x	Mic Setting
F7 Talk Setting								
Talk Volume	x	x	x	o	o	x	x	x
Talk Total Volume Attenuation	x	x	x	o	o	x	x	x
Talk Vocal Harmony Type	x	x	x	o	o	x	x	x
Talk Vocal Harmony On/Off	x	x	x	o	o	x	x	x
Talk Panpot	x	x	x	o	o	x	x	x
Talk Reverb Depth	x	x	x	o	o	x	x	x
Talk Chorus Depth	x	x	x	o	o	x	x	x
Talk DSP Depth	x	x	x	o	o	x	x	x
Talk DSP ON/OFF	x	x	x	o	o	x	x	x
Harmony/Echo								
Harmony/Echo On/Off	o	o	o	x	x	x	Harmony	x
Harmony/Echo Type	o	o	o	x	x	Harmony	Harmony	x
Harmony/Echo Volume	o	o	o	x	x	Harmony	Harmony	x
Harmony/Echo Assign	o	o	o	x	x	Harmony	Harmony	x
Harmony/Echo Chord Note Only	o	o	o	x	x	Harmony	Harmony	x
Harmony/Echo Touch Limit	o	o	o	x	x	Harmony	Harmony	x
Harmony/Echo Speed	o	o	o	x	x	Harmony	Harmony	x
Master EQ								
EQ No.	x	x	o	o	o	x	Voice	Master EQ
EQ Low (EQ1) Gain	x	x	x	x	x	x	x	Master EQ
EQ Low Mid (EQ2) Gain	x	x	x	x	x	x	x	Master EQ
EQ Mid (EQ3) Gain	x	x	x	x	x	x	x	Master EQ
EQ Mid High (EQ4) Gain	x	x	x	x	x	x	x	Master EQ
EQ High (EQ5) Gain	x	x	x	x	x	x	x	Master EQ
EQ Low (EQ1) Freq.	x	x	x	x	x	x	x	Master EQ
EQ Low Mid (EQ2) Freq.	x	x	x	x	x	x	x	Master EQ
EQ Mid (EQ3) Freq.	x	x	x	x	x	x	x	Master EQ
EQ Mid High (EQ4) Freq.	x	x	x	x	x	x	x	Master EQ
EQ High (EQ5) Freq.	x	x	x	x	x	x	x	Master EQ
EQ Low (EQ1) Q	x	x	x	x	x	x	x	Master EQ
EQ Low Mid (EQ2) Q	x	x	x	x	x	x	x	Master EQ
EQ Mid (EQ3) Q	x	x	x	x	x	x	x	Master EQ

	One Touch Setting	Music Database	Registration Memory	Setup (Disk)	System Backup	VoiceSet Group	Freeze Group	Parameter Lock
EQ Mid High (EQ4) Q	x	x	x	x	x	x	x	Master EQ
EQ High (EQ5) Q	x	x	x	x	x	x	x	Master EQ
EQ Edit Q (EQ1-EQ5)	x	x	x	x	x	x	x	Master EQ
EQ Edit Freq. (EQ1-EQ5)	x	x	x	x	x	x	x	Master EQ
EQ Edit Q Gain (EQ1-EQ5)	x	x	x	x	x	x	x	Master EQ
Scale Tune								
Scale Tuning (C)	x	x	o	x	x	x	Scale	x
Scale Tuning (C#)	x	x	o	x	x	x	Scale	x
Scale Tuning (D)	x	x	o	x	x	x	Scale	x
Scale Tuning (D#)	x	x	o	x	x	x	Scale	x
Scale Tuning (E)	x	x	o	x	x	x	Scale	x
Scale Tuning (F)	x	x	o	x	x	x	Scale	x
Scale Tuning (F#)	x	x	o	x	x	x	Scale	x
Scale Tuning (G)	x	x	o	x	x	x	Scale	x
Scale Tuning (G#)	x	x	o	x	x	x	Scale	x
Scale Tuning (A)	x	x	o	x	x	x	Scale	x
Scale Tuning (A#)	x	x	o	x	x	x	Scale	x
Scale Tuning (B)	x	x	o	x	x	x	Scale	x
Scale Tuning Arabic/Equal Temp.	x	x	o	x	x	x	Scale	x
Scale Tuning User Data (Multi Pad Bank #60)	x	x	x	o	o	x	Scale	x
Transpose								
Master Transpose	x	x	o	x	x	x	Tune Trans	x
Song Transpose	x	x	o	x	x	x	Tune Trans	x
Keyboard Transpose	x	x	o	x	x	x	Tune Trans	x
Transpose Assign	x	x	x	o	o	x	Tune Trans	x
Tempo								
Tempo	x	o	o	x	x	x	Tempo	x
Controller								
Foot Volume Master/Individual	x	x	o	x	x	x	Controller	x
Foot Volume Assign	x	x	o	x	x	x	Controller	x
Foot Sw1 Type	x	x	o	x	x	x	Controller	x
Foot Sw1 Part Assign	x	x	o	x	x	x	Controller	x
Foot Sw1 Percussion Kit #	x	x	o	x	x	x	Controller	x
Foot Sw1 Percussion Note #	x	x	o	x	x	x	Controller	x
Foot Sw1 Percussion Velocity	x	x	o	x	x	x	Controller	x
Foot Sw2 Type	x	x	o	x	x	x	Controller	x
Foot Sw2 Part Assign	x	x	o	x	x	x	Controller	x

Parameter Chart/Parameter-Tabelle/Tableau des paramètres

	One Touch Setting	Music Database	Registration Memory	Setup (Disk)	System Backup	VoiceSet Group	Freeze Group	Parameter Lock
Foot Sw2 Percussion Kit #	x	x	o	x	x	x	Controller	x
Foot Sw2 Percussion Note #	x	x	o	x	x	x	Controller	x
Foot Sw2 Percussion Velocity	x	x	o	x	x	x	Controller	x
Modulation Wheel Assign	x	x	o	x	x	x	Controller	x
Initial Touch Sw	x	x	o	x	x	x	Controller	x
Initial Touch Sensitivity	x	x	o	x	x	x	Controller	x
Initial Touch Fixed Velocity	x	x	o	x	x	x	Controller	x
Initial Touch Assign	x	x	o	x	x	x	Controller	x
After Touch Sensitivity	x	x	o	x	x	x	Controller	x
After Touch Assign	x	x	o	x	x	x	Controller	x
Multi Pad								
MultiPad Bank	o	o	o	x	x	x	MultiPad	x
MultiPad Bank Name	x	x	x	x	x	x	x	x
MultiPad Chord Match On/Off (Curent Bank Pad 1-4)	x	x	x	x	x	x	x	x
MultiPad Stop	x	x	x	x	x	x	x	x
MultiPad 1/2/3/4	x	x	x	x	x	x	x	x
MultiPad Repeat ON/OFF (Track1-60)	x	x	x	x	x	x	x	x
MultiPad Volume	o	o	o	x	x	x	MultiPad	x
MultiPad EQ Low	x	o	o	x	x	x	MultiPad	x
MultiPad EQ High	x	o	o	x	x	x	MultiPad	x
MultiPad Panpot	x	o	o	x	x	x	MultiPad	x
MultiPad Reverb Depth	x	o	o	x	x	x	MultiPad	x
MultiPad Chorus Depth	x	o	o	x	x	x	MultiPad	x
Registration Memory								
Registration Bank #	x	x	x	x	x	x	x	x
Registration Bank Name	x	x	x	x	x	x	x	x
Registration Name	x	x	x	x	x	x	x	x
Voice Set Assign Right1	x	x	x	o	o	x	x	x
Voice Set Assign Right2	x	x	x	o	o	x	x	x
Voice Set Assign Right3	x	x	x	o	o	x	x	x
Voice Set Assign Left	x	x	x	o	o	x	x	x
Freeze On/Off	x	x	x	x	x	x	x	x
Freeze Group Setting	x	x	x	o	o	x	x	x
MIDI								
MIDI Local Control	x	x	x	o	o	x	x	x
MIDI Clock Internal/External (A/B)	x	x	x	o	o	x	x	x
MIDI Transmit Ch. 1-32 settings	x	x	x	o	o	x	x	x
MIDI Receive Ch. 1-32 settings	x	x	x	o	o	x	x	x
MIDI Thru Port	x	x	x	o	o	x	x	x
MIDI Template No	x	x	x	o	o	x	x	x

	One Touch Setting	Music Database	Registration Memory	Setup (Disk)	System Backup	VoiceSet Group	Freeze Group	Parameter Lock
MIDI Transmit Clock	x	x	x	o	o	x	x	x
MIDI Receive transpose	x	x	x	o	o	x	x	x
MIDI Sys Ex Transmit	x	x	x	o	o	x	x	x
MIDI Sys Ex Receive	x	x	x	o	o	x	x	x
MIDI Chord Sys Ex Transmit	x	x	x	o	o	x	x	x
MIDI Chord Sys Ex Receive	x	x	x	o	o	x	x	x
MIDI Root	x	x	x	o	o	x	x	x
MIDI Chord Detect	x	x	x	o	o	x	x	x
MIDI MFC10 User Ch	x	x	x	x	x	x	x	x
MIDI MFC10 Template No.	x	x	x	o	o	x	x	x
MIDI MFC10 Foot Control	x	x	x	o	o	x	x	x
MIDI MFC10 SW Control	x	x	x	o	o	x	x	x
MIDI Template UserData	x	x	x	o	x	x	x	x
MIDI MFC10 On/Off	x	x	x	x	x	x	x	x
MIDI MFC10 Template User Data	x	x	x	o	x	x	x	x
UTILITY								
AutoLoad On/Off	x	x	x	o	o	x	x	x
Speaker On/Off	x	x	x	o	o	x	x	x
Display MIDI Bank Select & Program Change #	x	x	x	o	o	x	x	x
Metronome Volume For Rec	x	x	x	o	o	x	x	x
Poly Count	x	x	x	x	x	x	x	x
FD Cache	x	x	x	o	o	x	x	x
Parameter Lock	x	x	x	o	o	x	x	x
Auto Exit Time	x	x	x	o	o	x	x	x
Screen Saver Time	x	x	x	o	o	x	x	x
Language	x	x	x	o	o	x	x	x
PC Keyboard	x	x	x	o	o	x	x	x
VIDEO OUT								
NTSC/PAL	x	x	x	o	o	x	x	x
Background Color	x	x	x	o	o	x	x	x
Foreground Color	x	x	x	o	o	x	x	x
Size Large/Small	x	x	x	o	o	x	x	x
Other Settings								
Master Tune	x	x	x	o	o	x	x	x
Metronome On/Off (Play)	x	x	x	o	o	x	x	x
Metronome On/Off (Rec)	x	x	x	o	o	x	x	x
Metronome Volume	x	x	x	o	o	x	x	x
Password	x	x	x	x	o	x	x	x
Line Out Part	x	x	o	o	o	x	x	Line Out
Owner Name	x	x	x	o	o	x	x	x

Effect Type List/Effektartliste/Liste des types d'effet

● Reverb Type/Typ Widerhall/Type Reverb

Reverb Panel Order	Effect Name	Type MSB	Type LSB
1	Hall1	01	00
2	Hall2	01	16
3	Hall3	01	17
4	Hall4	01	18
5	Hall5	01	01
6	Hall M	01	06
7	Hall L	01	07
8	Room1	02	16
9	Room2	02	17
10	Room3	02	18
11	Room4	02	19
12	Room5	02	00
13	Room6	02	01
14	Room7	02	02
15	Room S	02	05
16	Room M	02	06
17	Room L	02	07
18	Stage1	03	16
19	Stage2	03	17
20	Stage3	03	00
21	Stage4	03	01
22	Plate1	04	16
23	Plate2	04	17
24	Plate3	04	00
25	GM Plate	04	07
26	WhiteRoom	16	00
27	Tunnel	17	00
28	Canyon	18	00
29	Basement	19	00
30	No Effect	00	00

● Chorus Type/Typ Chor/Type Chorus

Chorus Panel Order	Effect Name	Type MSB	Type LSB
1	Chorus1	66	17
2	Chorus2	66	08
3	Chorus3	66	16
4	Chorus4	66	01
5	Chorus5	65	02
6	Chorus6	65	00
7	Chorus7	65	01
8	Chorus8	65	08
9	GM Chorus1	65	03
10	GM Chorus2	65	04
11	GM Chorus3	65	05
12	GM Chorus4	65	06
13	FB Chorus	65	07
14	Celeste1	66	00
15	Celeste2	66	02
16	Flanger1	67	08
17	Flanger2	67	16
18	Flanger3	67	17
19	Flanger4	67	01
20	Flanger5	67	00
21	GM Flanger	67	07
22	Symphonic1	68	16
23	Symphonic2	68	00
24	Phaser1	72	00
25	EnsDetune (Ensemble Detune)	87	00
26	No Effect	00	00

● DSP Type/Typ DSP/Type DSP

DSP3 Panel Order	DSP4-7 Panel Order	DSP8 Panel Order	Effect Name	Type MSB	Type LSB
1	1	1	Hall1	01	00
2	2	2	Hall2	01	16
3	3	3	Room1	02	16
4	4	4	Room2	02	17
5	5	5	Stage1	03	16
6	6	6	Stage2	03	17
7	7	7	Chorus1	66	17
8	8	8	Chorus2	66	08
9	9	9	Symphonic1	68	16
10	10	10	TempoDelay	21	00
11	11	11	TempoEcho	21	08
12	12	12	TempoCross	22	00
13	13	13	DelayLCR1	05	16
14	14	14	DelayLR	06	00
15	15	15	Echo	07	00
16	16	16	CrossDelay	08	00
17	17	17	Flanger1	67	08
18	18	18	Flanger2	67	16
19	19	19	EP Phaser1	72	17
20	20	20	EP Phaser2	72	18
21	21	21	EP Phaser3	72	16
22	22	-	DualRotSP1 (Dual Rotor Speaker1)	99	00
23	23	-	DualRotSP2 (Dual Rotor Speaker2)	99	01
24	24	22	GtTremolo1 (Guitar Tremolo1)	70	19
25	25	23	EP Tremolo	70	18
26	26	24	EP AutoPan	71	21
27	27	-	StAmp1 (Stereo Amp Simulator1)	75	20
28	28	-	StAmp2 (Stereo Amp Simulator2)	75	21
29	29	-	VDstH+TDly (V Distortion Hard + Tempo Delay)	103	00
30	30	-	VDstS+TDly (V Distortion Soft + Tempo Delay)	103	01
31	31	-	V_DstH+Dly (V Distortion Hard + Delay)	98	01
32	32	-	V_DstS+Dly (V Distortion Soft + Delay)	98	03
33	33	-	Dst+TDly (Distortion + Tempo Delay)	100	00
34	34	-	Dst+2RotSP (Distortion + 2way Rotary Speaker)	86	01
35	35	-	OD+2RotSP (Overdrive + 2way Rotary Speaker)	86	02
36	36	-	Amp+2RotSP (Amp Simulator + 2way Rotary Speaker)	86	03
37	37	25	HmEnhance1 (Harmonic Enhancer1)	81	16
38	38	-	PitchChg1 (Pitch Change1)	80	16
39	39	-	ClaviTcWah (Clavi Touch Wah)	82	18
40	40	-	EP TcWah (EP Touch Wah)	82	19
41	41	26	AutoWah1	78	16
42	42	-	TcWah+Dst1 (Touch Wah + Distortion1)	82	16
43	43	-	AtWah+Dst1 (Auto Wah + Distortion1)	78	17
44	44	-	WhDst+TDly (Wah + Distortion + Tempo Delay)	102	00
45	45	-	WhDst+Dly1 (Wah + Distortion + Delay1)	97	16
46	46	27	Hall3	01	17
47	47	28	Hall4	01	18
48	48	29	Hall5	01	01
49	49	-	Hall M	01	06
50	50	-	Hall L	01	07
51	51	30	Room3	02	18
52	52	31	Room4	02	19
53	53	32	Room5	02	00
54	54	33	Room6	02	01
55	55	34	Room7	02	02
56	56	-	Room S	02	05
57	57	-	Room M	02	06
58	58	-	Room L	02	07
59	59	35	Stage3	03	00
60	60	36	Stage4	03	01

Effect Type List/Effektartliste/Liste des types d'effet

DSP3 Panel Order	DSP4-7 Panel Order	DSP8 Panel Order	Effect Name	Type MSB	Type LSB
61	61	37	Plate1	04	16
62	62	38	Plate2	04	17
63	63	39	Plate3	04	00
64	64	-	GM Plate	04	07
65	65	-	ER1	09	00
66	66	-	ER2	09	01
67	67	-	GateReverb	10	00
68	68	-	ReversGate	11	00
69	69	-	WhiteRoom	16	00
70	70	-	Tunnel	17	00
71	71	-	Canyon	18	00
72	72	-	Basement	19	00
73	73	40	Karaoke1	20	00
74	74	41	Karaoke2	20	01
75	75	42	Karaoke3	20	02
76	76	43	Chorus3	66	16
77	77	44	Chorus4	66	01
78	78	45	Chorus5	65	02
79	79	46	Chorus6	65	00
80	80	47	Chorus7	65	01
81	81	48	Chorus8	65	08
82	82	-	FB Chorus	65	07
83	83	-	GM Chorus1	65	03
84	84	-	GM Chorus2	65	04
85	85	-	GM Chorus3	65	05
86	86	-	GM Chorus4	65	06
87	87	49	Celeste1	66	00
88	88	50	Celeste2	66	02
89	89	51	Synphonic2	68	00
90	90	52	EnsDetune (Ensemble Detune)	87	00
91	91	53	DelayLCR2	05	00
92	92	54	Flanger3	67	17
93	93	55	Flanger4	67	01
94	94	56	Flanger5	67	00
95	95	-	GM Flanger	67	07
96	96	57	Phaser1	72	00
97	97	-	Phaser2	72	08
98	98	-	2wayRotSp (2way Rotary Speaker)	86	00
99	99	58	RotarySp1	69	16
100	100	59	RotarySp2 (Rotary Speaker2)	71	17
101	101	60	RotarySp3 (Rotary Speaker3)	71	18
102	102	61	RotarySp4	70	17
103	103	62	RotarySp5	66	18
104	104	63	RotarySp6	69	00
105	105	64	Tremolo1	70	16
106	106	65	Tremolo2	71	19
107	107	66	Tremolo3	70	00
108	108	67	AutoPan1	71	16
109	109	68	AutoPan2	71	00
110	110	69	GtTremolo2 (Guitar Tremolo2)	71	20
111	111	-	V_DistHard (V Distortion Hard)	98	00
112	112	-	V_DistSoft (V Distortion Soft)	98	02
113	113	-	StDistHard (Stereo Distortion Hard)	75	18
114	114	-	StDistSoft (Stereo Distortion Soft)	75	19
115	115	-	StDist (Stereo Distortion)	73	08
116	116	-	StOD (Stereo Overdrive)	74	08
117	117	-	StAmp3 (Stereo Amp Simulator3)	75	08
118	118	-	Comp+Dist1 (Compressor + Distortion1)	73	16
119	119	-	Comp+Dist2 (Compressor + Distortion2)	73	01
120	120	70	DistHard (Distortion Hard)	75	16
121	121	71	DistSoft (Distortion Soft)	75	17
122	122	72	DistHvy (Distortion Heavy)	73	00
123	123	73	OverDrive	74	00
124	124	74	AmpSim (Amp Simulator)	75	00
125	125	-	CmpDsiTDly (Compressor + Distortion + Tempo Delay)	101	00
126	126	-	CmpOD+TDly (Compressor + Overdrive + Tempo Delay)	101	01

DSP3 Panel Order	DSP4-7 Panel Order	DSP8 Panel Order	Effect Name	Type MSB	Type LSB
127	127	-	OD+TDly (Overdrive + Tempo Delay)	100	01
128	128	-	CmpDstDly1 (Compressor + Distortion + Delay1)	96	16
129	129	-	CmpDstDly2 (Compressor + Distortion + Delay2)	96	00
130	130	-	CmpODDly1 (Compressor + Overdrive + Delay1)	96	17
131	131	-	CmpODDly2 (Compressor + Overdrive + Delay2)	96	01
132	132	-	Dst+Delay1 (Distortion + Delay1)	95	16
133	133	-	Dst+Delay2 (Distortion + Delay2)	95	00
134	134	-	OD+Delay1 (Overdrive + Delay1)	95	17
135	135	-	OD+Delay2 (Overdrive + Delay2)	95	01
136	136	-	Dst+RotSP (Distortion + Rotary Speaker)	69	01
137	137	-	OD+RotSP (Overdrive + Rotary Speaker)	69	02
138	138	-	Amp+RotSP (Amp Simulator + Rotary Speaker)	69	03
139	139	75	Compressor	83	00
140	140	76	NoiseGate	84	00
141	141	77	EQDisco	76	16
142	142	78	EQTel	76	17
143	143	79	3BandEQ	76	00
144	144	80	2BandEQ	77	00
145	145	81	HmEnhance2 (Harmonic Enhancer2)	81	00
146	146	-	VoicCancel (Voice Cancel)	85	00
147	147	-	Ambience	88	00
148	148	-	Lo-Fi	94	00
149	149	-	PitchChg2 (Pitch Change2)	80	00
150	150	-	PitchChg3 (Pitch Change3)	80	01
151	151	82	AutoWah2	78	00
152	152	-	AtWah+Dst2 (Auto Wah + Distortion2)	78	01
153	153	-	AtWah+OD1 (Auto Wah + Overdrive1)	78	18
154	154	-	AtWah+OD2 (Auto Wah + Overdrive2)	78	02
155	155	83	TouchWah1	82	00
156	156	84	TouchWah2	82	08
157	157	-	TcWah+Dst2 (Touch Wah + Distortion2)	82	01
158	158	-	TcWah+OD1 (Touch Wah + Overdrive1)	82	17
159	159	-	TcWah+OD2 (Touch Wah + Overdrive2)	82	02
160	160	-	WhDst+Dly2 (Wah + Distortion + Delay2)	97	00
161	161	-	Wh+OD+TDly (Wah + Overdrive + Tempo Delay)	102	01
162	162	-	Wh+OD+Dly1 (Wah + Overdrive + Delay1)	97	17
163	163	-	Wh+OD+Dly2 (Wah + Overdrive + Delay2)	97	01
164	164	-	TalkingMod (Talking Modulation)	93	00
165	-	-	No Effect	00	00
166	165	85	Thru	64	00

Effect Parameter List/Effektparameterliste/

XG Effect Name

HALL1,HALL2
ROOM1,ROOM2,ROOM3
STAGE1,STAGE2

TypeMSB (Type LSB)

MSB = 01
MSB = 02
MSB = 03
MSB = 04

PLATE (reverb, variation, insertion block)

No.	Parameter	Display	Value	See Table	Control
1	Reverb Time	0.3-30.0s	0-69	table#4	
2	Diffusion	0-10	0-10		
3	Initial Delay	0.1mS-99.3mS	0-63	table#5	
4	HPF Cutoff	Thru-8.0kHz	0-52	table#3	
5	LPF Cutoff	1.0k-Thru	34-60	table#3	
6					
7					
8					
9					
10	Dry/Wet	D63>W ~ D=W ~ D<W63	1-127		●
11	Rev Delay	0.1mS-99.3mS	0-63	table#5	
12	Density	0-4 (reverb, variation, insertion 1-4 block) 0-2 (insertion 5 block)	0-4		
13	Er/Rev Balance	E63>R ~ E=R ~ E<R63	1-127		
14	High Damp	0.1-1.0	1-10		
15	Feedback Level	-63+63	1-127		
16					

DELAY L,C,R (variation, insertion block)

MSB = 05

No.	Parameter	Display	Value	See Table	Control
1	Lch Delay	0.1-1.4860s (variation block)	1-14860		
		0.1-1.4860s (insertion block)	1-14860		
2	Rch Delay	0.1-1.4860s (variation block)	1-14860		
		0.1-1.4860s (insertion block)	1-14860		
3	Cch Delay	0.1-1.4860s (variation block)	1-14860		
		0.1-1.4860s (insertion block)	1-14860		
4	Feedback Delay	0.1-1.4860s (variation block)	1-14860		
		0.1-1.4860s (insertion block)	1-14860		
5	Feedback Level	-63+63	1-127		
6	Cch Level	0-127	0-127		
7	High Damp	0.1-1.0	1-10		
8					
9					
10	Dry/Wet	D63>W ~ D=W ~ D<W63	1-127		●
11					
12					
13	EQ Low Frequency	32Hz-2.0kHz	4-40	table#3	
14	EQ Low Gain	-12+12dB	52-76		
15	EQ High Frequency	500Hz-16.0kHz	28-58	table#3	
16	EQ High Gain	-12+12dB	52-76		

DELAY L,R (variation, insertion block)

MSB = 06

No.	Parameter	Display	Value	See Table	Control
1	Lch Delay	0.1-1.4860s (variation block)	1-14860		
		0.1-1.4860s (insertion block)	1-14860		
2	Rch Delay	0.1-1.4860s (variation block)	1-14860		
		0.1-1.4860s (insertion block)	1-14860		
3	Feedback Delay 1	0.1-1.4860s (variation block)	1-14860		
		0.1-1.4860s (insertion block)	1-14860		
4	Feedback Delay 2	0.1-1.4860s (variation block)	1-14860		
		0.1-1.4860s (insertion block)	1-14860		
5	Feedback Level	-63+63	1-127		
6	High Damp	0.1-1.0	1-10		
7					
8					
9					
10	Dry/Wet	D63>W ~ D=W ~ D<W63	1-127		●
11					
12					
13	EQ Low Frequency	32Hz-2.0kHz	4-40	table#3	
14	EQ Low Gain	-12+12dB	52-76		
15	EQ High Frequency	500Hz-16.0kHz	28-58	table#3	
16	EQ High Gain	-12+12dB	52-76		

ECHO (variation, insertion block)

MSB = 07

No.	Parameter	Display	Value	See Table	Control
1	Lch Delay1	0.1-743.0ms (variation block)	1-7430		
		0.1-743.0ms (insertion block)	1-7430		
2	Lch Feedback Level	-63+63	1-127		
3	Rch Delay1	0.1-743.0ms (variation block)	1-7430		
		0.1-743.0ms (insertion block)	1-7430		
4	Rch Feedback Level	-63+63	1-127		
5	High Damp	0.1-1.0	1-10		
6	Lch Delay2	0.1-743.0ms (variation block)	1-7430		
		0.1-743.0ms (insertion block)	1-7430		
7	Rch Delay2	0.1-743.0ms (variation block)	1-7430		
		0.1-743.0ms (insertion block)	1-7430		
8	Delay2 Level	0-127	0-127		
9					
10	Dry/Wet	D63>W ~ D=W ~ D<W63	1-127		●
11					
12					
13	EQ Low Frequency	32Hz-2.0kHz	4-40	table#3	
14	EQ Low Gain	-12+12dB	52-76		
15	EQ High Frequency	500Hz-16.0kHz	28-58	table#3	
16	EQ High Gain	-12+12dB	52-76		

CROSS DELAY (variation, insertion block)

MSB = 08

No.	Parameter	Display	Value	See Table	Control
1	L->R Delay	0.1-743.0ms (variation block)	1-7430		
		0.1-743.0ms (insertion block)	1-7430		
2	R->L Delay	0.1-743.0ms (variation block)	1-7430		
		0.1-743.0ms (insertion block)	1-7430		
3	Feedback Level	-63+63	1-127		
4	Input Select	L,R,L&R	0-2		
5	High Damp	0.1-1.0	1-10		
6					
7					
8					
9					
10	Dry/Wet	D63>W ~ D=W ~ D<W63	1-127		●
11					
12					
13	EQ Low Frequency	32Hz-2.0kHz	4-40	table#3	
14	EQ Low Gain	-12+12dB	52-76		
15	EQ High Frequency	500Hz-16.0kHz	28-58	table#3	
16	EQ High Gain	-12+12dB	52-76		

EARLY REF1,EARLY REF2(variation, Insertion1-4 block)

MSB = 09

No.	Parameter	Display	Value	See Table	Control
1	Type	S,H, L,H, Rdm, Rvs, Plt, Spr	0-5		
2	Room Size	0.1-7.0	0-44	table#6	
3	Diffusion	0-10	0-10		
4	Initial Delay	0.1mS-200.0mS	0-127	table#5	
5	Feedback Level	-63+63	1-127		
6	HPF Cutoff	Thru-8.0kHz	0-52	table#3	
7	LPF Cutoff	1.0k-Thru	34-60	table#3	
8					
9					
10	Dry/Wet	D63>W ~ D=W ~ D<W63	1-127		●
11	Liveness	0-10	0-10		
12	Density	0-3	0-3		
13	High Damp	0.1-1.0	1-10		
14					
15					
16					

GATE REVERB

REVERSE GATE (variation, Insertion1-4 block)

MSB = 10

MSB = 11

No.	Parameter	Display	Value	See Table	Control
1	Type	TypeA,TypeB	0-1		
2	Room Size	0.1-7.0	0-44	table#6	
3	Diffusion	0-10	0-10		
4	Initial Delay	0.1mS-200.0mS	0-127	table#5	
5	Feedback Level	-63+63	1-127		
6	HPF Cutoff	Thru-8.0kHz	0-52	table#3	
7	LPF Cutoff	1.0k-Thru	34-60	table#3	
8					
9					
10	Dry/Wet	D63>W ~ D=W ~ D<W63	1-127		●
11	Liveness	0-10	0-10		
12	Density	0-3	0-3		
13	High Damp	0.1-1.0	1-10		
14					
15					
16					

WHITE ROOM

TUNNEL

CANYON

BASEMENT (reverb, variation, Insertion1-4 block)

MSB = 16

MSB = 17

MSB = 18

MSB = 19

No.	Parameter	Display	Value	See Table	Control
1	Reverb Time	0.3-30.0s	0-69	table#4	
2	Diffusion	0-10	0-10		
3	Initial Delay	0.1mS-99.3mS	0-63	table#5	
4	HPF Cutoff	Thru-8.0kHz	0-52	table#3	
5	LPF Cutoff	1.0k-Thru	34-60	table#3	
6	Width	0.5-10.2m	0-37	table#11	
7	Height	0.5-20.2m	0-73	table#11	
8	Depth	0.5-30.2m	0-104	table#11	
9	Wall Vary	0-30	0-30		
10	Dry/Wet	D63>W ~ D=W ~ D<W63	1-127		●
11	Rev Delay	0.1mS-99.3mS	0-63	table#5	
12	Density	0-4	0-4		
13	Er/Rev Balance	E63>R ~ E=R ~ E<R63	1-127		
14	High Damp	0.1-1.0	1-10		
15	Feedback Level	-63+63	1-127		
16					

KARAOKE1,2,3 (variation, insertion block)

MSB = 20

No.	Parameter	Display	Value	See Table	Control
1	Delay Time	0.1mS-400.0mS	0-127	table#7	
2	Feedback Level	-63+63	1-127		
3	HPF Cutoff	Thru-8.0kHz	0-52	table#3	
4	LPF Cutoff	1.0k-Thru	34-60	table#3	
5					
6					
7					
8					
9					
10	Dry/Wet	D63>W ~ D=W ~ D<W63	1-127		●
11					
12					
13					
14					
15					
16					

TEMPO DELAY (variation, insertion block)

TEMPO ECHO (variation, insertion block)

MSB = 21

No.	Parameter	Display	Value	See Table	Control
1	Delay Time	64th/3 ~ 4thx6	0-19	table#14	
2	Feedback Level	-63 +63	1-127		
3	Feedback High Dump	0 ~ 1.0	0-10		
4	L/R Diffusion	1(-63ms)-64(0ms)-127(63ms)	1-127		
5	Lag	1(-63ms)-64(0ms)-127(63ms)	1-127		
6					
7					
8					
9					
10	Dry/Wet	D63>W ~ D=W ~ D<W=63	1-127		●
11					
12					
13	EQ Low Frequency	32-2.0KH	4-40		
14	EQ Low Gain	-12 ~ +12dB	52-76		
15	EQ High Frequency	500 ~ 16.0kHz	28-58		
16	EQ High Gain	-12 ~ +12dB	52-76		

TEMPO CROSS (variation, Insertion block)

MSB = 22

No.	Parameter	Display	Value	See Table	Control
1	Delay Time L>R	64th/3 ~ 4thx6	0-19	table#14	
2	Delay Time R>L	64th/3 ~ 4thx6	0-19	table#14	
3	Feedback Level	-63 +63	1-127		
4	Input Select	L, R, L&R	0-2		
5	Feedback High Dump	0 ~ 1.0	0-10		
6	Lag	1(-63ms)-64(0ms)-127(63ms)	1-127		
7					
8					
9					
10	Dry/Wet	D63>W ~ D=W ~ D<W=63	1-127		●
11					
12					
13	EQ Low Frequency	32-2.0KH	4-40		
14	EQ Low Gain	-12 ~ +12dB	52-76		
15	EQ High Frequency	500 ~ 16.0kHz	28-58		
16	EQ High Gain	-12 ~ +12dB	52-76		

Liste des paramètres d'effet de voix

CHORUS1,2,3,4 **MSB = 65**
CELESTE1,2,3,4 (chorus, variation, insertion block) **MSB = 66**

No.	Parameter	Display	Value	See Table	Control
1	LFO Frequency	0.00Hz-39.7Hz	0-127	table#1	
2	LFO Depth	0-127	0-127		
3	Feedback Level	-63-+63	1-127		
4	Delay Offset	0.0mS-50mS	0-127	table#2	
5					
6	EQ Low Frequency	32Hz-2.0kHz	4-40	table#3	
7	EQ Low Gain	-12-+12dB	52-76		
8	EQ High Frequency	500Hz-16.0kHz	28-58	table#3	
9	EQ High Gain	-12-+12dB	52-76		
10	Dry/Wet	D63>W ~ D=W ~ D<W63	1-127		●
11	EQ Mid Frequency	100Hz-10.0kHz (var/ins1-4 block)	14-54	table#3	
12	EQ Mid Gain	-12-+12dB (var/ins1-4 block)	52-76		
13	EQ Mid Width	1.0-12.0 (var/ins1-4 block)	10-120		
14					
15	Input Mode	mono/stereo	0-1		
16					

FLANGER1,2,3 (chorus, variation, insertion block) **MSB = 67**

No.	Parameter	Display	Value	See Table	Control
1	LFO Frequency	0.00Hz-39.7Hz	0-127	table#1	
2	LFO Depth	0-127	0-127		
3	Feedback Level	-63-+63	1-127		
4	Delay Offset	0.0mS-50mS	0-127	table#2	
5					
6	EQ Low Frequency	32Hz-2.0kHz	4-40	table#3	
7	EQ Low Gain	-12-+12dB	52-76		
8	EQ High Frequency	500Hz-16.0kHz	28-58	table#3	
9	EQ High Gain	-12-+12dB	52-76		
10	Dry/Wet	D63>W ~ D=W ~ D<W63	1-127		●
11	EQ Mid Frequency	100Hz-10.0kHz (var/ins1-4 block)	14-54	table#3	
12	EQ Mid Gain	-12-+12dB (var/ins1-4 block)	52-76		
13	EQ Mid Width	1.0-12.0 (var/ins1-4 block)	10-120		
14	LFO Phase Difference	-180-+180deg(resolution=3deg.)	4-124		
15					
16					

SYMPHONIC (chorus, variation, insertion block) **MSB = 68**

No.	Parameter	Display	Value	See Table	Control
1	LFO Frequency	0.00Hz-39.7Hz	0-127	table#1	
2	LFO Depth	0-127	0-127		
3	Delay Offset	0.0mS-50mS	0-127	table#2	
4					
5					
6	EQ Low Frequency	32Hz-2.0kHz	4-40	table#3	
7	EQ Low Gain	-12-+12dB	52-76		
8	EQ High Frequency	500Hz-16.0kHz	28-58	table#3	
9	EQ High Gain	-12-+12dB	52-76		
10	Dry/Wet	D63>W ~ D=W ~ D<W63	1-127		●
11	EQ Mid Frequency	100Hz-10.0kHz (var/ins1-4 block)	14-54	table#3	
12	EQ Mid Gain	-12-+12dB (var/ins1-4 block)	52-76		
13	EQ Mid Width	1.0-12.0 (var/ins1-4 block)	10-120		
14					
15					
16					

ROTARY SPEAKER (variation, insertion block) **MSB = 69, LSB = 0, 16**

No.	Parameter	Display	Value	See Table	Control
1	LFO Frequency	0.00Hz-39.7Hz	0-127	table#1	●
2	LFO Depth	0-127	0-127		
3					
4					
5					
6	EQ Low Frequency	32Hz-2.0kHz	4-40	table#3	
7	EQ Low Gain	-12-+12dB	52-76		
8	EQ High Frequency	500Hz-16.0kHz	28-58	table#3	
9	EQ High Gain	-12-+12dB	52-76		
10	Dry/Wet	D63>W ~ D=W ~ D<W63	1-127		
11	EQ Mid Frequency	100Hz-10.0kHz (var/ins1-4 block)	14-54	table#3	
12	EQ Mid Gain	-12-+12dB (var/ins1-4 block)	52-76		
13	EQ Mid Width	1.0-12.0 (var/ins1-4 block)	10-120		
14					
15					
16					

DISTORTION+ROTARY SPEAKER (variation, insertion1-4 block) **MSB = 69, LSB = 1**
OVERDRIVE+ROTARY SPEAKER (variation, insertion1-4 block) **MSB = 69, LSB = 2**

No.	Parameter	Display	Value	See Table	Control
1	LFO Frequency	0.0-39.7Hz	0-127		●
2	LFO Depth	0-127	0-127		
3					
4					
5					
6	EQ Low Frequency	32-2.0kHz	4-40		
7	EQ Low Gain	-12 ~ +12dB	52-76		
8	EQ High Frequency	500 ~ 16.0kHz	28-58		
9	EQ High Gain	-12 ~ +12dB	52-76		
10	Dry/Wet	D63>W ~ D=W ~ D<W=63	1-127		
11					
12					
13					
14	Drive	0-127	0-127		
15	LPF Cutoff	1kHz-Thru	34-60		
16	Output Level	0-127	0-127		

AMP SIM.+ROTARY SPEAKER (variation, Insertion1-4 block) **MSB = 69, LSB = 3**

No.	Parameter	Display	Value	See Table	Control
1	LFO Frequency	0.0-39.7Hz	0-127		●
2	LFO Depth	0-127	0-127		
3	AMP Type	Off,Stack,Combo,Tube	0-3		
4					
5					
6	EQ Low Frequency	32-2.0kHz	4-40		
7	EQ Low Gain	-12 ~ +12dB	52-76		
8	EQ High Frequency	500 ~ 16.0kHz	28-58		
9	EQ High Gain	-12 ~ +12dB	52-76		
10	Dry/Wet	D63>W ~ D=W ~ D<W=63	1-127		
11					
12					
13					
14	Drive	0-127	0-127		
15	LPF Cutoff	1kHz-Thru	34-60		
16	Output Level	0-127	0-127		

TREMOLO (variation, insertion block) **MSB = 70**

No.	Parameter	Display	Value	See Table	Control
1	LFO Frequency	0.00Hz-39.7Hz	0-127	table#1	●
2	AM Depth	0-127	0-127		
3	PM Depth	0-127	0-127		
4					
5					
6	EQ Low Frequency	32Hz-2.0kHz	4-40	table#3	
7	EQ Low Gain	-12-+12dB	52-76		
8	EQ High Frequency	500Hz-16.0kHz	28-58	table#3	
9	EQ High Gain	-12-+12dB	52-76		
10					
11	EQ Mid Frequency	100Hz-10.0kHz (var/ins1-4 block)	14-54	table#3	
12	EQ Mid Gain	-12-+12dB (var/ins1-4 block)	52-76		
13	EQ Mid Width	1.0-12.0 (var/ins1-4 block)	10-120		
14	LFO Phase Difference	-180-+180deg(resolution=3deg.)	4-124		
15	Input Mode	mono/stereo	0-1		
16					

AUTO PAN (variation, insertion block) **MSB = 71**

No.	Parameter	Display	Value	See Table	Control
1	LFO Frequency	0.00Hz-39.7Hz	0-127	table#1	●
2	LFO Depth	0-127	0-127		
3	F/R Depth	0-127	0-127		
4	PAN Direction	L<->R,L->R,L<-R,Lturn,Rturn,L/R	0-5		
5					
6	EQ Low Frequency	32Hz-2.0kHz	4-40	table#3	
7	EQ Low Gain	-12-+12dB	52-76		
8	EQ High Frequency	500Hz-16.0kHz	28-58	table#3	
9	EQ High Gain	-12-+12dB	52-76		
10					
11	EQ Mid Frequency	100Hz-10.0kHz (var/ins1-4 block)	14-54	table#3	
12	EQ Mid Gain	-12-+12dB (var/ins1-4 block)	52-76		
13	EQ Mid Width	1.0-12.0 (var/ins1-4 block)	10-120		
14					
15					
16					

PHASER 1 (chorus, variation, insertion block) **MSB = 72, LSB = 0, 16, 17, 18**

No.	Parameter	Display	Value	See Table	Control
1	LFO Frequency	0.00Hz-39.7Hz	0-127	table#1	
2	LFO Depth	0-127	0-127		
3	Phase Shift Offset	0-127	0-127		
4	Feedback Level	-63-+63	1-127		
5					
6	EQ Low Frequency	32Hz-2.0kHz	4-40	table#3	
7	EQ Low Gain	-12-+12dB	52-76		
8	EQ High Frequency	500Hz-16.0kHz	28-58	table#3	
9	EQ High Gain	-12-+12dB	52-76		
10	Dry/Wet	D63>W ~ D=W ~ D<W63	1-127		●
11	Stage	4,5,6 (chorus, insertion5 block)	4-6		
12	Diffusion	4-12 (var/ins1-4 block)	4-12		
13		mono/stereo	0-1		
14					
15					
16					

PHASER 2 (variation, Insertion1-4 block) **MSB = 72, LSB = 8**

No.	Parameter	Display	Value	See Table	Control
1	LFO Frequency	0.00Hz-39.7Hz	0-127	table#1	
2	LFO Depth	0-127	0-127		
3	Phase Shift Offset	0-127	0-127		
4	Feedback Level	-63-+63	1-127		
5					
6	EQ Low Frequency	32Hz-2.0kHz	4-40	table#3	
7	EQ Low Gain	-12-+12dB	52-76		
8	EQ High Frequency	500Hz-16.0kHz	28-58	table#3	
9	EQ High Gain	-12-+12dB	52-76		
10	Dry/Wet	D63>W ~ D=W ~ D<W63	1-127		●
11	Stage	3,4,5,6	4-6		
12					
13	LFO Phase Difference	-180deg-+180deg(resolution=3deg.)	4-124		
14					
15					
16					

DISTORTION OVERDRIVE (variation, insertion block) **MSB = 73, LSB = 0**
MSB = 74

No.	Parameter	Display	Value	See Table	Control
1	Drive	0-127	0-127		●
2	EQ Low Frequency	32Hz-2.0kHz	4-40	table#3	
3	EQ Low Gain	-12-+12dB	52-76		
4	LPF Cutoff	1.0k-Thru	34-60	table#3	
5	Output Level	0-127	0-127		
6					
7	EQ Mid Frequency	100Hz-10.0kHz	14-54	table#3	
8	EQ Mid Gain	-12-+12dB	52-76		
9	EQ Mid Width	1.0-12.0	10-120		
10	Dry/Wet	D63>W ~ D=W ~ D<W63	1-127		
11	Edge(Clip Curve)	0-127	0-127	mild-sharp	
12					
13					
14					
15					
16					

COMP+DIST (variation, Insertion1-4 block) **MSB = 73, LSB = 1, 16**

No.	Parameter	Display	Value	See Table	Control
1	Drive	0-127	0-127		●
2	EQ Low Frequency	32Hz-2.0kHz	4-40	table#3	
3	EQ Low Gain	-12-+12dB	52-76		
4	LPF Cutoff	1.0k-Thru	34-60	table#3	
5	Output Level	0-127	0-127		
6					
7	EQ Mid Frequency	100Hz-10.0kHz	14-54	table#3	
8	EQ Mid Gain	-12-+12dB	52-76		
9	EQ Mid Width	1.0-12.0	10-120		
10	Dry/Wet	D63>W ~ D=W ~ D<W63	1-127		
11	Edge(Clip Curve)	0-127	0-127	mild-sharp	
12	Attack	1ms-40ms	0-19	table#8	
13	Release	10ms-680ms	0-15	table#9	
14	Threshold	-48dB-6dB	79-121		
15	Ratio	1.0-20.0	0-7	table#10	
16					

Effect Parameter List/Effektparameterliste/Liste des paramètres d'effet de voix

STEREO DISTORTION (variation, Insertion1-4 block)
STEREO OVER DRIVE (variation, Insertion1-4 block)

MSB = 73, LSB = 8
MSB = 74, LSB = 8

No.	Parameter	Display	Value	See Table	Control
1	Drive	0-127	0-127		●
2	EQ Low Frequency	32-2.0kHz	4-40	table#3	
3	EQ Low Gain	-12 ~ +12dB	52-76		
4	LPF Cutoff	1kHz-Thru	34-60		
5	Output Level	0-127	0-127		
6					
7	EQ Mid Frequency	100 ~ 10.0kHz	14-54	table#3	
8	EQ Mid Gain	-12 ~ +12dB	52-76		
9	EQ Mid Width	1 ~ 12	10-120		
10	Dry/Wet	D63>W ~ D=W ~ D<W63	1-127		
11	Edge	0-127	0-127		
12					
13					
14					
15					
16					

AUTO WAH+DIST
AUTO WAH+ODRV (variation, Insertion1-4 block)

MSB = 78, LSB = 1, 17
MSB = 78, LSB = 2, 18

No.	Parameter	Display	Value	See Table	Control
1	LFO Frequency	0.00Hz-39.7Hz	0-127	table#1	
2	LFO Depth	0-127	0-127		
3	Cutoff Frequency Offset	0-127	0-127		●
4	Resonance	1.0-12.0	10-120		
5					
6	EQ Low Frequency	32Hz-2.0kHz	4-40	table#3	
7	EQ Low Gain	-12~+12dB	52-76		
8	EQ High Frequency	500Hz-16.0kHz	28-58	table#3	
9	EQ High Gain	-12~+12dB	52-76		
10	Dry/Wet	D63>W ~ D=W ~ D<W63	1-127		
11	Drive	0-127	0-127		
12	EQ Low Gain(distortion)	-12~+12dB	52-76		
13	EQ Mid Gain(distortion)	-12~+12dB	52-76		
14	LPF Cutoff	1.0kHz-thru	34-60	table#3	
15	Output Level	0-127	0-127		
16					

AMP SIMULATOR (variation, insertion block)

MSB = 75, LSB = 0, 16, 17

No.	Parameter	Display	Value	See Table	Control
1	Drive	0-127	0-127		●
2	AMP Type	Off, Stack, Combo, Tube	0-3		
3	LPF Cutoff	1.0k-Thru	34-60	table#3	
4	Output Level	0-127	0-127		
5					
6					
7					
8					
9					
10	Dry/Wet	D63>W ~ D=W ~ D<W63	1-127		
11	Edge(Clip Curve)	0-127	0-127	mild-sharp	
12					
13					
14					
15					
16					

PITCH CHANGE 1 (variation, Insertion1-4 block)

MSB = 80, LSB = 0, 16

No.	Parameter	Display	Value	See Table	Control
1	Pitch	-24~+24	40-58	table#7	
2	Initial Delay	0.1mS-400.0mS	0-127		
3	Fine 1	-50~+50	14-114		
4	Fine 2	-50~+50	14-114		
5	Feedback Level	-63~+63	1-127		
6					
7					
8					
9					
10	Dry/Wet	D63>W ~ D=W ~ D<W63	1-127		●
11	Pan 1	L63-R63	1-127		
12	Output Level 1	0-127	0-127		
13	Pan 2	L63-R63	1-127		
14	Output Level 2	0-127	0-127		
15					
16					

STEREO AMP SIMULATOR (variation, Insertion1-4 block)

MSB = 75, LSB = 8, 18, 19, 20, 21

No.	Parameter	Display	Value	See Table	Control
1	Drive	0-127	0-127		●
2	AMP Type	Off, Stack, Combo, Tube	0-3		
3	LPF Cutoff	1kHz-Thru	34-60		
4	Output Level	0-127	0-127		
5					
6					
7					
8					
9					
10	Dry/Wet	D63>W ~ D=W ~ D<W63	1-127		
11	Edge	0-127	0-127		
12					
13					
14					
15					
16					

PITCH CHANGE 2 (variation, Insertion1-4 block)

MSB = 80, LSB = 1

No.	Parameter	Display	Value	See Table	Control
1	Pitch	-24~+24	40-58	table#7	
2	Initial Delay	0.1mS-400.0mS	0-127		
3	Fine 1	-50~+50cent	14-114		
4	Fine 2	-50~+50cent	14-114		
5	Feedback Level	-63~+63	1-127		
6					
7					
8					
9					
10	Dry/Wet	D63>W ~ D=W ~ D<W63	1-127		●
11	Pan 1	L63-R63	1-127		
12	Output Level 1	0-127	0-127		
13	Pan 2	L63-R63	1-127		
14	Output Level 2	0-127	0-127		
15					
16					

3BAND EQ(MONO) (variation, insertion block)

MSB = 76

No.	Parameter	Display	Value	See Table	Control
1	EQ Low Gain	-12~+12dB	52-76		
2	EQ Mid Frequency	100Hz-10.0kHz	14-54	table#3	
3	EQ Mid Gain	-12~+12dB	52-76		
4	EQ Mid Width	1.0-12.0	10-120		
5	EQ High Gain	-12~+12dB	52-76		
6	EQ Low Frequency	50Hz-2.0kHz	8-40	table#3	
7	EQ High Frequency	500Hz-16.0kHz	28-58	table#3	
8					
9					
10					
11					
12					
13					
14					
15	Input Mode	mono/stereo	0-1		
16					

HARMONIC ENHANCER (variation, Insertion block)

MSB = 81

No.	Parameter	Display	Value	See Table	Control
1	HPPF Cutoff	500Hz-16.0kHz	28-58		
2	Drive	0-127	0-127		
3	Mix Level	0-127	0-127		
4					
5					
6					
7					
8					
9					
10					
11					
12					
13					
14					
15					
16					

2BAND EQ(STEREO) (variation, insertion block)

MSB = 77

No.	Parameter	Display	Value	See Table	Control
1	EQ Low Frequency	32Hz-2.0kHz	4-40	table#3	
2	EQ Low Gain	-12~+12dB	52-76		
3	EQ High Frequency	500Hz-16.0kHz	28-58	table#3	
4	EQ High Gain	-12~+12dB	52-76		
5					
6					
7					
8					
9					
10					
11					
12					
13					
14					
15					
16					

TOUCH WAH 1 (variation, insertion block)

MSB = 82, LSB = 0

No.	Parameter	Display	Value	See Table	Control
1	Sensitive	0-127	0-127		
2	Cutoff Frequency Offset	0-127	0-127		●
3	Resonance	1.0-12.0	10-120		
4					
5					
6	EQ Low Frequency	32Hz-2.0kHz	4-40	table#3	
7	EQ Low Gain	-12~+12dB	52-76		
8	EQ High Frequency	500Hz-16.0kHz	28-58	table#3	
9	EQ High Gain	-12~+12dB	52-76		
10	Dry/Wet	D63>W ~ D=W ~ D<W63	1-127		
11	Drive	0-127 (var/ins1-4 block)	0-127		
12					
13					
14					
15					
16					

AUTO WAH (variation, insertion block)

MSB = 78, LSB = 0, 16

No.	Parameter	Display	Value	See Table	Control
1	LFO Frequency	0.00Hz-39.7Hz	0-127	table#1	
2	LFO Depth	0-127	0-127		
3	Cutoff Frequency Offset	0-127	0-127		●
4	Resonance	1.0-12.0	10-120		
5					
6	EQ Low Frequency	32Hz-2.0kHz	4-40	table#3	
7	EQ Low Gain	-12~+12dB	52-76		
8	EQ High Frequency	500Hz-16.0kHz	28-58	table#3	
9	EQ High Gain	-12~+12dB	52-76		
10	Dry/Wet	D63>W ~ D=W ~ D<W63	1-127		
11	Drive	0-127 (var/ins1-4 block)	0-127		
12					
13					
14					
15					
16					

TOUCH WAH 2 (variation, insertion block)

MSB = 82, LSB = 8

No.	Parameter	Display	Value	See Table	Control
1	Sensitive	0-127	0-127		
2	Cutoff Frequency Offset	0-127	0-127		●
3	Resonance	1.0-12.0	10-120		
4					
5					
6	EQ Low Frequency	32Hz-2.0kHz	4-40	table#3	
7	EQ Low Gain	-12~+12dB	52-76		
8	EQ High Frequency	500Hz-16.0kHz	28-58	table#3	
9	EQ High Gain	-12~+12dB	52-76		
10	Dry/Wet	D63>W ~ D=W ~ D<W63	1-127		
11	Drive	0-127 (var/ins1-4 block)	0-127		
12	EQ Low Gain(distortion)	-12~+12dB (var/ins1-4 block)	52-76		
13	EQ Mid Gain(distortion)	-12~+12dB (var/ins1-4 block)	52-76		
14	LPF Cutoff	1.0kHz-thru(var/ins1-4 block)	34-60	table#3	
15	Output Level	0-127(var/ins1-4 block)	0-127		
16	Release	10-680mS(var/ins1-4 block)	52-67	table#12	

Effect Parameter List/Effektparameterliste/Liste des paramètres d'effet de voix

COMPRESSOR (variation, insertion block)

MSB = 83

No.	Parameter	Display	Value	See Table	Control
1	Attack	1-40ms	0-19	table#8	
2	Release	10-680ms	0-15	table#9	
3	Threshold	-48--6dB	79-121		
4	Ratio	1.0-20.0	0-7	table#10	
5	Output Level	0-127	0-127		
6					
7					
8					
9					
10					
11					
12					
13					
14					
15					
16					

NOISE GATE (variation, insertion block)

MSB = 84

No.	Parameter	Display	Value	See Table	Control
1	Attack	1-40ms	0-19	table#8	
2	Release	10-680ms	0-15	table#9	
3	Threshold	-72--30dB	55-97		
4	Output Level	0-127	0-127		
5					
6					
7					
8					
9					
10					
11					
12					
13					
14					
15					
16					

VOICE CANCEL (variation, Insertion1-4 block)

MSB = 85

No.	Parameter	Display	Value	See Table	Control
1					
2					
3					
4					
5					
6					
7					
8					
9					
10					
11	Low Adjust	0-26	0-26		
12	High Adjust	0-26	0-26		
13					
14					
15					
16					

2WAY ROTARY SPEAKER (variation, Insertion1-4 block)

MSB = 86, LSB = 0

No.	Parameter	Display	Value	See Table	Control
1	Rotor Speed	0.0Hz-39.7Hz	0-127	table#1	●
2	Drive Low	0-127	0-127		
3	Drive High	0-127	0-127		
4	Low/High Balance	L63>H - L=H ~ L<H=63	1-127		
5					
6	EQ Low Frequency	32Hz-2.0kHz	4-40	table#3	
7	EQ Low Gain	-12~+12dB	52-76		
8	EQ High Frequency	500Hz-16.0kHz	28-58	table#3	
9	EQ High Gain	-12~+12dB	52-76		
10					
11	Crossover Frequency	100Hz-10.0kHz	14-54	table#3	
12	Mic L-R Angle	0deg-180deg(resolution=3deg.)	0-60		
13					
14					
15					
16					

DIST+2WAY ROTARY SPEAKER (variation, Insertion1-4 block)

MSB = 86, LSB = 1

No.	Parameter	Display	Value	See Table	Control
1	Rotor Speed	0.0-39.7Hz	0-127		●
2	Drive Low	0-127	0-127		
3	Drive High	0-127	0-127		
4	Low/High Balance	L63>H - L=H ~ L<H=63	1-127		
5					
6	EQ Low Frequency	32-2.0kHz	4-40		
7	EQ Low Gain	-12 ~ +12dB	52-76		
8	EQ High Frequency	500 ~ 16.0kHz	28-58		
9	EQ High Gain	-12 ~ +12dB	52-76		
10					
11	Crossover Frequency	100 ~ 10.0kHz	14-54		
12	Mic L-R Angle	0 ~ 180deg	0-60		
13					
14	Drive		0-127		
15	LPF Cutoff	1kHz-Thru	34-60		
16	Output Level		0-127		

AMP SIM.+2WAY ROTARY SP (variation, Insertion1-4 block)

MSB = 86, LSB = 3

No.	Parameter	Display	Value	See Table	Control
1	Rotor Speed	0.0-39.7Hz	0-127		●
2	Drive Low	0-127	0-127		
3	Drive High	0-127	0-127		
4	Low/High Balance	L63>H - L=H ~ L<H=63	1-127		
5					
6	EQ Low Frequency	32-2.0kHz	4-40		
7	EQ Low Gain	-12 ~ +12dB	52-76		
8	EQ High Frequency	500 ~ 16.0kHz	28-58		
9	EQ High Gain	-12 ~ +12dB	52-76		
10					
11	Crossover Frequency	100 ~ 10.0kHz	14-54		
12	Mic L-R Angle	0 ~ 180deg	0-60		
13	AMP Type	Off,Stack,Combo,Tube(AMPSIM only)	0-3		
14	Drive		0-127		
15	LPF Cutoff	1kHz-Thru	34-60		
16	Output Level		0-127		

ENSEMBLE DETUNE (chorus, variation, insertion block)

MSB = 87

No.	Parameter	Display	Value	See Table	Control
1	Detune	-50~+50cent	14-114		
2	Lch Init Delay	0.0mS-50mS	0-127	table#2	
3	Rch Init Delay	0.0mS-50mS	0-127	table#2	
4					
5					
6					
7					
8					
9					
10	Dry/Wet	D63>W ~ D=W ~ D<W63	1-127		●
11	EQ Low Frequency	32Hz-2.0kHz (variation, insertion block)	4-40	table#3	
12	EQ Low Gain	-12~+12dB (variation, insertion block)	52-76		
13	EQ High Frequency	500Hz-16.0kHz (variation, insertion block)	28-58	table#3	
14	EQ High Gain	-12~+12dB (variation, insertion block)	52-76		
15					
16					

AMBIENCE (variation, Insertion1-4 block)

MSB = 88

No.	Parameter	Display	Value	See Table	Control
1	Delay Time	0.0mS-50mS	0-127	table#2	
2	Output Phase	normal/invers	0-1		
3					
4					
5					
6	EQ Low Frequency	32Hz-2.0kHz	4-40	table#3	
7	EQ Low Gain	-12~+12dB	52-76		
8	EQ High Frequency	500Hz-16.0kHz	28-58	table#3	
9	EQ High Gain	-12~+12dB	52-76		
10	Dry/Wet	D63>W ~ D=W ~ D<W63	1-127		●
11					
12					
13					
14					
15					
16					

TALKING MODULATION (variation, Insertion1-4 block)

MSB = 93

No.	Parameter	Display	Value	See Table	Control
1	Vowel	a,i,u,e,o	0-4		●
2	Move speed	1-62	1-62		
3	Drive	0-127	0-127		
4	Output Level	0-127	0-127		
5					
6					
7					
8					
9					
10					
11					
12					
13					
14					
15					
16					

LO-FI (variation, Insertion1-4 block)

MSB = 94

No.	Parameter	Display	Value	See Table	Control
1	Sampling Freq Control	44.1kHz-345Hz	0-127	table#13	
2	Word Length	1-127	1-127		
3	Output Gain	-6~+12dB	0-18	table#3	
4	LPF Cutoff	63Hz-Thru	10-60		
5	Filter Type	Thru,PowerBass,Radio,Tel,Clean,Low	0-5		
6	LPF Resonance	1.0-12.0	10-120		
7	Bt Assign	0-6	0-6		
8	Emphasis	Off/On	0-1		
9					
10	Dry/Wet	D63>W ~ D=W ~ D<W63	1-127		●
11					
12					
13					
14					
15	Input Mode	mono/stereo			
16					

DIST+DELAY (variation, Insertion1-4 block)

OVERDRIVE+DELAY (variation, Insertion1-4 block)

MSB = 95

No.	Parameter	Display	Value	See Table	Control
1	Lch Delay Time	0.1-1.4860s	1-14860		
2	Rch Delay Time	0.1-1.4860s	1-14860		
3	Delay Feedback Time	0.1-1.4860s	1-14860		
4	Delay Feedback Level	-63~+63	1-127		
5	Delay Mix	0-127	0-127		
6	Dist Drive	0-127	0-127		
7	Dist Output Level	0-127	0-127		
8	Dist EQ Low Gain	-12~+12dB	52-76		
9	Dist EQ Mid Gain	-12~+12dB	52-76		
10	Dry/Wet	D63>W ~ D=W ~ D<W63	1-127		●
11					
12					
13					
14					
15					
16					

COMP+DIST+DELAY (variation, Insertion1-4 block)

COMP+OVERDRIVE+DELAY (variation, Insertion1-4 block)

MSB = 96

No.	Parameter	Display	Value	See Table	Control
1	Delay Time	0.1-1.4860s	1-14860		
2	Delay Feedback Level	-63~+63	1-127		
3	Delay Mix	0-127	0-127		
4	Dist Drive	0-127	0-127		
5	Dist Output Level	0-127	0-127		
6	Dist EQ Low Gain	-12~+12dB	52-76		
7	Dist EQ Mid Gain	-12~+12dB	52-76		
8					
9					
10	Dry/Wet	D63>W ~ D=W ~ D<W63	1-127		●
11	Comp. Attack	1ms-40ms	0-19	table#8	
12	Comp. Release	10ms-680ms	0-15	table#9	
13	Comp. Threshold	-48dB--6dB	79-121		
14	Comp. Ratio	1.0-20.0	0-7	table#10	
15					
16					

Effect Parameter List/Effektparameterliste/Liste des paramètres d'effet de voix

WAH+DIST+DELAY (variation, Insertion1-4 block)

WAH+OVERDRIVE+DELAY (variation, Insertion1-4 block)

MSB = 97

No.	Parameter	Display	Value	See Table	Control
1	Delay Time	0.1-1.4860s	1-14860		
2	Delay Feedback Level	-63~+63	1-127		
3	Delay Mix	0-127	0-127		
4	Dist Drive	0-127	0-127		
5	Dist Output Level	0-127	0-127		
6	Dist EQ Low Gain	-12~+12dB	52-76		
7	Dist EQ Mid Gain	-12~+12dB	52-76		
8					
9					
10	Dry/Wet	D63>W ~ D=W ~ D<W63	1-127		●
11	Wah Sensitive	0-127	0-127		
12	Wah Cutoff Freq Offset	0-127	0-127		
13	Wah Resonance	1.0-12.0	10-120		
14	Wah Release	10-680ms	52-67	table#12	
15					
16					

V DISTORTION HARD (variation, Insertion1-4 block)

MSB = 98, LSB = 0

V DISTORTION SOFT (variation, Insertion1-4 block)

MSB = 98, LSB = 2

No.	Parameter	Display	Value	See Table	Control
1	Overdrive	0-100%	0-100		
2	Device	Transister/Vintage Tube/ Dist1/Dist2/Fuzz	0-4		
3	Speaker	Flat/Stack/Combo/Twin/ Radio/Megaphone	0-5		
4	Presence	0-20	0-20		
5	Output Level	0-100%	0-100		
6					
7					
8					
9					
10	Dry/Wet Balance	D63>W-D=W-D<W63	1-127		●
11					
12					
13					
14					
15					
16					

V DISTORTION HARD+DELAY (variation, Insertion1-4 block)

MSB = 98, LSB = 1

V DISTORTION SOFT+DELAY (variation, Insertion1-4 block)

MSB = 98, LSB = 3

No.	Parameter	Display	Value	See Table	Control
1	Overdrive	0-100%	0-100		
2	Device	Transister/Vintage Tube/ Dist1/Dist2/Fuzz	0-4		
3	Speaker	Flat/Stack/Combo/Twin/ Radio/Megaphone	0-5		
4	Presence	0-20	0-20		
5	Output Level	0-100%	0-100		
6	Delay Time L	0.1ms-1.4860s	1-14860		
7	Delay Time R	0.1ms-1.4860s	1-14860		
8	Delay Feedback Time	0.1ms-1.4860s	1-14860		
9	Delay Feedback Level	-63~+63	1-127		
10	Dry/Wet Balance	D63>W-D=W-D<W63	1-127		●
11	Delay Mix	0-127	0-127		
12					
13					
14					
15					
16					

DUAL ROTOR SPEAKER1,2 (variation, Insertion1-4 block)

MSB = 99

No.	Parameter	Display	Value	See Table	Control
1	Rotor Speed Slow	0.0-2.65Hz	0-63	table#1	
2	Horn Speed Slow	0.0-2.65Hz	0-63	table#1	
3	Rotor Speed Fast	2.69-39.7Hz	64-127	table#1	
4	Horn Speed Fast	2.69-39.7Hz	64-127	table#1	
5	Slow-Fast Time of R	0-127	0-127		
6	Slow-Fast Time of H	0-127	0-127		
7	Drive Low	0-127	0-127		
8	Drive High	0-127	0-127		
9	Low/High Balance	L63>H ~ L=H ~ L<H=63	1-127		
10					
11	EQ Low Frequency	32-2.0kHz	4-40	table#3	
12	EQ Low Gain	-12 ~ +12dB	52-76		
13	EQ High Frequency	500 ~ 16.0kHz	28-58	table#3	
14	EQ High Gain	-12 ~ +12dB	52-76		
15	Mic L-R Angle	0 ~ 180deg	0-60		
16	Speed Control	Slow/Fast	0/1		●

DIST+TEMPO DELAY (variation, Insertion1-4 block)

OVERDRIVE+TEMPO DELAY (variation, Insertion1-4 block)

MSB = 100

No.	Parameter	Display	Value	See Table	Control
1	Delay Time	64th/3 ~ 4thx6	0-19	table#14	
2	Delay Feedback Level	-63 ~ +63	1-127		
3	Delay Mix	0 ~ 127	0-127		
4	Dist Drive	0 ~ 127	0-127		
5	Dist Output Level	0 ~ 127	0-127		
6	Dist EQ Low Gain	-12 ~ +12dB	52-76		
7	Dist EQ High Gain	-12 ~ +12dB	52-76		
8	L/R Diffusion	1(-63ms)-64(0ms)-127(63ms)	1-127		
9	Lag	1(-63ms)-64(0ms)-127(63ms)	1-127		
10	Dry/Wet	D63>W ~ D=W ~ D<W=63	1-127		●
11					
12					
13					
14					
15					
16					

COMP+DIST+TEMPO DELAY (variation, Insertion1-4 block)

COMP+OD+TEMPO DELAY (variation, Insertion1-4 block)

MSB = 101

No.	Parameter	Display	Value	See Table	Control
1	Delay Time	64th/3 ~ 4thx6	0-19	table#14	
2	Delay Feedback Level	-63 ~ +63	1-127		
3	Delay Mix	0 ~ 127	0-127		
4	Dist Drive	0 ~ 127	0-127		
5	Dist Output Level	0 ~ 127	0-127		
6	Dist EQ Low Gain	-12 ~ +12dB	52-76		
7	Dist EQ High Gain	-12 ~ +12dB	52-76		
8	L/R Diffusion	1(-63ms)-64(0ms)-127(63ms)	1-127		
9	Lag	1(-63ms)-64(0ms)-127(63ms)	1-127		
10	Dry/Wet	D63>W ~ D=W ~ D<W=63	1-127		●
11	Comp. Attack	1ms ~ 40ms	0-19		
12	Comp. Release	10ms ~ 680ms	0-15		
13	Comp. Threshold	-48dB ~ -6dB	79-121		
14	Comp. Ratio	1.0 ~ 20.0	0-7		
15					
16					

WAH+DIST+TEMPO DELAY (variation, Insertion1-4 block)

WAH+OD+TEMPO DELAY (variation, Insertion1-4 block)

MSB = 102

No.	Parameter	Display	Value	See Table	Control
1	Delay Time	64th/3 ~ 4thx6	0-19	table#14	
2	Delay Feedback Level	-63 ~ +63	1-127		
3	Delay Mix	0 ~ 127	0-127		
4	Dist Drive	0 ~ 127	0-127		
5	Dist Output Level	0 ~ 127	0-127		
6	Dist EQ Low Gain	-12 ~ +12dB	52-76		
7	Dist EQ High Gain	-12 ~ +12dB	52-76		
8	L/R Diffusion	1(-63ms)-64(0ms)-127(63ms)	1-127		
9	Lag	1(-63ms)-64(0ms)-127(63ms)	1-127		
10	Dry/Wet	D63>W ~ D=W ~ D<W=63	1-127		●
11	Wah Sensitive	0 ~ 127	0-127		
12	Wah Cutoff Freq Offset	0 ~ 127	0-127		
13	Wah Resonance	1.0 ~ 12.0	10-120		
14	Wah Release	10 ~ 680ms	52-67		
15					
16					

V DIST HARD+TEMPO DELAY (variation, Insertion1-4 block)

V DIST SOFT+TEMPO DELAY (variation, Insertion1-4 block)

MSB = 103

No.	Parameter	Display	Value	See Table	Control
1	Overdrive	0-100%	0-100		
2	Device	Transister/Vintage Tube/ Dist1/Dist2/Fuzz	0-4		
3	Speaker	Flat/Stack/Combo/Twin/ Radio/Megaphone	0-5		
4	Presence	0-20	0-20		
5	Output Level	0-100%	0-100		
6	Delay Time	64th/3 ~ 4thx6	0-19	table#14	
7	Delay Feedback Level	-63 ~ +63	1-127		
8	L/R Diffusion	1(-63ms)-64(0ms)-127(63ms)	1-127		
9	Lag	1(-63ms)-64(0ms)-127(63ms)	1-127		
10	Dry/Wet Balance	D63>W-D=W-D<W63	1-127		●
11	Delay Mix	0-127	0-127		
12					
13					
14					
15					
16					

NO EFFECT (reverb, chorus, variation block)

MSB = 0

No.	Parameter	Display	Value	See Table	Control
1					
2					
3					
4					
5					
6					
7					
8					
9					
10					
11					
12					
13					
14					
15					
16					

THRU (variation, insertion block)

MSB = 64

No.	Parameter	Display	Value	See Table	Control
1					
2					
3					
4					
5					
6					
7					
8					
9					
10					
11					
12					
13					
14					
15					
16					

* Parameter 10 Dry/Wet only affects insertion type effects.

Effect Data Value Assign Table/Effektdatenwert-Zuordnungstabelle/Table d'affectation des valeurs pour les données d'effets

Table #1

LFO Frequency							
Data	Value	Data	Value	Data	Value	Data	
0	0.00	32	1.35	64	2.69	96	8.41
1	0.04	33	1.39	65	2.78	97	8.75
2	0.08	34	1.43	66	2.86	98	9.08
3	0.13	35	1.47	67	2.94	99	9.42
4	0.17	36	1.51	68	3.03	100	9.76
5	0.21	37	1.56	69	3.11	101	10.1
6	0.25	38	1.60	70	3.20	102	10.8
7	0.29	39	1.64	71	3.28	103	11.4
8	0.34	40	1.68	72	3.37	104	12.1
9	0.38	41	1.72	73	3.45	105	12.8
10	0.42	42	1.77	74	3.53	106	13.5
11	0.46	43	1.81	75	3.62	107	14.1
12	0.51	44	1.85	76	3.70	108	14.8
13	0.55	45	1.89	77	3.87	109	15.5
14	0.59	46	1.94	78	4.04	110	16.2
15	0.63	47	1.98	79	4.21	111	16.8
16	0.67	48	2.02	80	4.37	112	17.5
17	0.72	49	2.06	81	4.54	113	18.2
18	0.76	50	2.10	82	4.71	114	19.5
19	0.80	51	2.15	83	4.88	115	20.9
20	0.84	52	2.19	84	5.05	116	22.2
21	0.88	53	2.23	85	5.22	117	23.6
22	0.93	54	2.27	86	5.38	118	24.9
23	0.97	55	2.31	87	5.55	119	26.2
24	1.01	56	2.36	88	5.72	120	27.6
25	1.05	57	2.40	89	6.06	121	28.9
26	1.09	58	2.44	90	6.39	122	30.3
27	1.14	59	2.48	91	6.73	123	31.6
28	1.18	60	2.52	92	7.07	124	33.0
29	1.22	61	2.57	93	7.40	125	34.3
30	1.26	62	2.61	94	7.74	126	37.0
31	1.30	63	2.65	95	8.08	127	39.7

Table #4

Reverb time							
Data	Value	Data	Value	Data	Value	Data	
0	0.3	32	3.5	64	17.0		
1	0.4	33	3.6	65	18.0		
2	0.5	34	3.7	66	19.0		
3	0.6	35	3.8	67	20.0		
4	0.7	36	3.9	68	25.0		
5	0.8	37	4.0	69	30.0		
6	0.9	38	4.1				
7	1.0	39	4.2				
8	1.1	40	4.3				
9	1.2	41	4.4				
10	1.3	42	4.5				
11	1.4	43	4.6				
12	1.5	44	4.7				
13	1.6	45	4.8				
14	1.7	46	4.9				
15	1.8	47	5.0				
16	1.9	48	5.5				
17	2.0	49	6.0				
18	2.1	50	6.5				
19	2.2	51	7.0				
20	2.3	52	7.5				
21	2.4	53	8.0				
22	2.5	54	8.5				
23	2.6	55	9.0				
24	2.7	56	9.5				
25	2.8	57	10.0				
26	2.9	58	11.0				
27	3.0	59	12.0				
28	3.1	60	13.0				
29	3.2	61	14.0				
30	3.3	62	15.0				
31	3.4	63	16.0				

Table #7

Delay Time(400.0ms)							
Data	Value	Data	Value	Data	Value	Data	
0	0.1	32	100.9	64	201.6	96	302.4
1	3.2	33	104.0	65	204.8	97	305.5
2	6.4	34	107.2	66	207.9	98	308.7
3	9.5	35	110.3	67	211.1	99	311.8
4	12.7	36	113.5	68	214.2	100	315.0
5	15.8	37	116.6	69	217.4	101	318.1
6	19.0	38	119.8	70	220.5	102	321.3
7	22.1	39	122.9	71	223.7	103	324.4
8	25.3	40	126.1	72	226.8	104	327.6
9	28.4	41	129.2	73	230.0	105	330.7
10	31.6	42	132.4	74	233.1	106	333.9
11	34.7	43	135.5	75	236.3	107	337.0
12	37.9	44	138.6	76	239.4	108	340.2
13	41.0	45	141.8	77	242.6	109	343.3
14	44.2	46	144.9	78	245.7	110	346.5
15	47.3	47	148.1	79	248.9	111	349.6
16	50.5	48	151.2	80	252.0	112	352.8
17	53.6	49	154.4	81	255.2	113	355.9
18	56.8	50	157.5	82	258.3	114	359.1
19	59.9	51	160.7	83	261.5	115	362.2
20	63.1	52	163.8	84	264.6	116	365.4
21	66.2	53	167.0	85	267.7	117	368.5
22	69.4	54	170.1	86	270.9	118	371.7
23	72.5	55	173.3	87	274.0	119	374.8
24	75.7	56	176.4	88	277.2	120	378.0
25	78.8	57	179.6	89	280.3	121	381.1
26	82.0	58	182.7	90	283.5	122	384.3
27	85.1	59	185.9	91	286.6	123	387.4
28	88.3	60	189.0	92	289.8	124	390.6
29	91.4	61	192.2	93	292.9	125	393.7
30	94.6	62	195.3	94	296.1	126	396.9
31	97.7	63	198.5	95	299.2	127	400.0

Table #12

Wah Release Time	
Data	Value
52	10.0
53	15.0
54	25.0
55	35.0
56	45.0
57	55.0
58	65.0
59	75.0
60	85.0
61	100.0
62	115.0
63	140.0
64	170.0
65	230.0
66	340.0
67	680.0

Table #2

Modulation Delay Offset							
Data	Value	Data	Value	Data	Value	Data	
0	0.0	32	3.2	64	6.4	96	9.6
1	0.1	33	3.3	65	6.5	97	9.7
2	0.2	34	3.4	66	6.6	98	9.8
3	0.3	35	3.5	67	6.7	99	9.9
4	0.4	36	3.6	68	6.8	100	10.0
5	0.5	37	3.7	69	6.9	101	11.1
6	0.6	38	3.8	70	7.0	102	12.2
7	0.7	39	3.9	71	7.1	103	13.3
8	0.8	40	4.0	72	7.2	104	14.4
9	0.9	41	4.1	73	7.3	105	15.5
10	1.0	42	4.2	74	7.4	106	17.1
11	1.1	43	4.3	75	7.5	107	18.6
12	1.2	44	4.4	76	7.6	108	20.2
13	1.3	45	4.5	77	7.7	109	21.8
14	1.4	46	4.6	78	7.8	110	23.3
15	1.5	47	4.7	79	7.9	111	24.9
16	1.6	48	4.8	80	8.0	112	26.5
17	1.7	49	4.9	81	8.1	113	28.0
18	1.8	50	5.0	82	8.2	114	29.6
19	1.9	51	5.1	83	8.3	115	31.2
20	2.0	52	5.2	84	8.4	116	32.8
21	2.1	53	5.3	85	8.5	117	34.3
22	2.2	54	5.4	86	8.6	118	35.9
23	2.3	55	5.5	87	8.7	119	37.5
24	2.4	56	5.6	88	8.8	120	39.0
25	2.5	57	5.7	89	8.9	121	40.6
26	2.6	58	5.8	90	9.0	122	42.2
27	2.7	59	5.9	91	9.1	123	43.7
28	2.8	60	6.0	92	9.2	124	45.3
29	2.9	61	6.1	93	9.3	125	46.9
30	3.0	62	6.2	94	9.4	126	48.4
31	3.1	63	6.3	95	9.5	127	50.0

Table #5

Delay Time(200.0ms)							
Data	Value	Data	Value	Data	Value	Data	
0	0.1	32	50.5	64	100.8	96	151.2
1	1.7	33	52.0	65	102.4	97	152.8
2	3.2	34	53.6	66	104.0	98	154.4
3	4.8	35	55.2	67	105.6	99	155.9
4	6.4	36	56.8	68	107.1	100	157.5
5	8.0	37	58.3	69	108.7	101	159.1
6	9.5	38	59.9	70	110.3	102	160.6
7	11.1	39	61.5	71	111.9	103	162.2
8	12.7	40	63.1	72	113.4	104	163.8
9	14.3	41	64.6	73	115.0	105	165.4
10	15.8	42	66.2	74	116.6	106	166.9
11	17.4	43	67.8	75	118.2	107	168.5
12	19.0	44	69.4	76	119.7	108	170.1
13	20.6	45	70.9	77	121.3	109	171.7
14	22.1	46	72.5	78	122.9	110	173.2
15	23.7	47	74.1	79	124.4	111	174.8
16	25.3	48	75.7	80	126.0	112	176.4
17	26.9	49	77.2	81	127.6	113	178.0
18	28.4	50	78.8	82	129.2	114	179.5
19	30.0	51	80.4	83	130.7	115	181.1
20	31.6	52	81.9	84	132.3	116	182.7
21	33.2	53	83.5	85	133.9	117	184.3
22	34.7	54	85.1	86	135.5	118	185.8
23	36.3	55	86.7	87	137.0	119	187.4
24	37.9	56	88.2	88	138.6	120	189.0
25	39.5	57	89.8	89	140.2	121	190.6
26	41.0	58	91.4	90	141.8	122	192.1
27	42.6	59	93.0	91	143.3	123	193.7
28	44.2	60	94.5	92	144.9	124	195.3
29	45.7	61	96.1	93	146.5	125	196.9
30	47.3	62	97.7	94	148.1	126	198.4
31	48.9	63	99.3	95	149.6	127	200.0

Table #8

Compressor	
Data	Value
0	1
1	2
2	3
3	4
4	5
5	6
6	7
7	8
8	9
9	10
10	11
11	12
12	13
13	14

MIDI Data Format/MIDI-Datenformat/Format de données

Many MIDI messages listed in the MIDI Data Format are expressed in decimal numbers, binary numbers and hexadecimal numbers. Hexadecimal numbers may include the letter "H" as a suffix. Also, "n" can freely be defined as any whole number. To enter data/values, refer to the table below.

Decimal	Hexadecimal	Binary
0	00	0000 0000
1	01	0000 0001
2	02	0000 0010
3	03	0000 0011
4	04	0000 0100
5	05	0000 0101
6	06	0000 0110
7	07	0000 0111
8	08	0000 1000
9	09	0000 1001
10	0A	0000 1010
11	0B	0000 1011
12	0C	0000 1100
13	0D	0000 1101
14	0E	0000 1110
15	0F	0000 1111
16	10	0001 0000
17	11	0001 0001
18	12	0001 0010
19	13	0001 0011
20	14	0001 0100
21	15	0001 0101
22	16	0001 0110
23	17	0001 0111
24	18	0001 1000
25	19	0001 1001
26	1A	0001 1010
27	1B	0001 1011
28	1C	0001 1100
29	1D	0001 1101
30	1E	0001 1110
31	1F	0001 1111

Decimal	Hexadecimal	Binary
32	20	0010 0000
33	21	0010 0001
34	22	0010 0010
35	23	0010 0011
36	24	0010 0100
37	25	0010 0101
38	26	0010 0110
39	27	0010 0111
40	28	0010 1000
41	29	0010 1001
42	2A	0010 1010
43	2B	0010 1011
44	2C	0010 1100
45	2D	0010 1101
46	2E	0010 1110
47	2F	0010 1111
48	30	0011 0000
49	31	0011 0001
50	32	0011 0010
51	33	0011 0011
52	34	0011 0100
53	35	0011 0101
54	36	0011 0110
55	37	0011 0111
56	38	0011 1000
57	39	0011 1001
58	3A	0011 1010
59	3B	0011 1011
60	3C	0011 1100
61	3D	0011 1101
62	3E	0011 1110
63	3F	0011 1111

Decimal	Hexadecimal	Binary
64	40	0100 0000
65	41	0100 0001
66	42	0100 0010
67	43	0100 0011
68	44	0100 0100
69	45	0100 0101
70	46	0100 0110
71	47	0100 0111
72	48	0100 1000
73	49	0100 1001
74	4A	0100 1010
75	4B	0100 1011
76	4C	0100 1100
77	4D	0100 1101
78	4E	0100 1110
79	4F	0100 1111
80	50	0101 0000
81	51	0101 0001
82	52	0101 0010
83	53	0101 0011
84	54	0101 0100
85	55	0101 0101
86	56	0101 0110
87	57	0101 0111
88	58	0101 1000
89	59	0101 1001
90	5A	0101 1010
91	5B	0101 1011
92	5C	0101 1100
93	5D	0101 1101
94	5E	0101 1110
95	5F	0101 1111

Decimal	Hexadecimal	Binary
96	60	0110 0000
97	61	0110 0001
98	62	0110 0010
99	63	0110 0011
100	64	0110 0100
101	65	0110 0101
102	66	0110 0110
103	67	0110 0111
104	68	0110 1000
105	69	0110 1001
106	6A	0110 1010
107	6B	0110 1011
108	6C	0110 1100
109	6D	0110 1101
110	6E	0110 1110
111	6F	0110 1111
112	70	0111 0000
113	71	0111 0001
114	72	0111 0010
115	73	0111 0011
116	74	0111 0100
117	75	0111 0101
118	76	0111 0110
119	77	0111 0111
120	78	0111 1000
121	79	0111 1001
122	7A	0111 1010
123	7B	0111 1011
124	7C	0111 1100
125	7D	0111 1101
126	7E	0111 1110
127	7F	0111 1111

- Except the table above, for example 144-159(decimal)/9nH/1001 0000-1001 1111(binary) denotes the Note On Message for each channel (1-16). 176-191/BnH/1011 0000-1011 1111 denotes the Control Change Message for each channel (1-16). 192-207/CnH/1100 0000-1100 1111 denotes the Program Change Message for each channel (1-16). 240/FOH/1111 0000 denotes the start of a System Exclusive Message. 247/F7H/1111 0111 denotes the end of a System Exclusive Message.
- aaH (hexadecimal)/0aaaaaaa (binary) denotes the data address. The address contains High, Mid, and Low.
- bbH/0bbbbbbb denotes the byte count.
- ccH/0ccccccc denotes the check sum.
- ddH/0ddddddd denotes the data/value.

Channel/Mode/Realtime Messages/ Kanal / Modus / Realtime-Meldungen/ Messages canal/de mode/temps réel

o : available

MIDI Events	Status byte		1st Data byte		2nd Data byte		Recognized								
	Status		Data (HEX)	Parameter	Data (HEX)	Parameter	XG/GM	Key-board	R1	R2	R3	Left	Acmp		
Key Off	8nH	(n:channel no.)	kk	Key no. (0~127)	vv	Velocity(0~127)	o	o	o	o	o	o	o		
Key On	9nH		kk	Key no. (0~127)	vv	Key On :vv=1~127 Key Off :vv=0	o	o	o	o	o	o	o		
Control Change	BnH		0 (00H)	Bank Select MSB	0 (00H) 64 (40H) 126 (7EH) 127 (7FH)	Normal SFX voice SFX kit Drum	o	o	o	o	o	o	o		
			32 (20H)	Bank Select LSB	0~112~ (0...70H...)	XG voice Panel voice									
			1 (01H)	Modulation	0~127 (...7FH)		o	o	o	o	o	o	o	o	o
			5 (05H)	Portament Time	0~127 (...7FH)		o	o	o	o	o	o	o	o	x
			6 (06H)	Data Entry MSB	0~127 (...7FH)										
			38 (26H)	Data Entry LSB	0~127 (...7FH)		o	o	o	o	o	o	o	o	o
			7 (07H)	Main Volume	0~127 (...7FH)		o	o	o	o	o	o	o	o	o
			10 (0AH)	Panpot	0~127 (...7FH)		o	o	o	o	o	o	o	o	o
			11 (0BH)	Expression	0~127 (...7FH)		o	o	o	o	o	o	o	o	o
			64 (40H)	Sustain(Damper)	0~127 (...7FH)		o	o	o	o	o	o	o	o	x
			65 (41H)	Portament	0~127 (...7FH)		o	o	o	o	o	o	o	o	x
			66 (42H)	Sostenuto	0~127 (...7FH)		o	o	o	o	o	o	o	o	x
			67 (43H)	Soft Pedal	0~127 (...7FH)		o	o	o	o	o	o	o	o	x
			71 (47H)	Harmonic Content	0~127 (...7FH)		o	o	o	o	o	o	o	o	o
			72 (48H)	Release Time	0~127 (...7FH)		o	o	o	o	o	o	o	o	o
			73 (49H)	Attack Time	0~127 (...7FH)		o	o	o	o	o	o	o	o	o
			74 (4AH)	Brightness	0~127 (...7FH)		o	o	o	o	o	o	o	o	o
			84 (54H)	Portamento Control	0~127 (...7FH)		o	o	o	o	o	o	o	o	o
			91 (5BH)	Effect1 Depth (Reverb Send Level)	0~127 (...7FH)		o	o	o	o	o	o	o	o	o
			93 (5DH)	Effect3 Depth (Chorus Send Level)	0~127 (...7FH)		o	o	o	o	o	o	o	o	o
			94 (5EH)	Effect4 Depth (Variation Send Level)	0~127 (...7FH)		o	o	o	o	o	o	o	o	o
96 (60H)	Increment	0~127 (...7FH)													
97 (61H)	Decrement	0~127 (...7FH)		o	x	o	o	o	o	o	o	o			
98 (62H)	NRPN LSB	0~127 (...7FH)		o	x	o	o	o	o	o	o	o			
99 (63H)	NRPN MSB	0~127 (...7FH)		o	x	o	o	o	o	o	o	o			
100 (64H)	RPN LSB	0~127 (...7FH)		o	o	o	o	o	o	o	o	o			
101 (65H)	RPN MSB	0~127 (...7FH)		o	o	o	o	o	o	o	o	o			
Mode Message	BnH		120 (78H)	All sound off	0		o	o	o	o	o	o	o		
			121 (79H)	Reset all controller	0		o	x	x	x	x	x	x		
			122 (7AH)	Local control	dd	dd=00H: Off 7FH: On	x	x	x	x	x	x	x		
			123 (7BH)	All note off	0		o	o	o	o	o	o	o	o	
			124 (7CH)	OMNI OFF	0		o	o	o	o	o	o	o	o	
			125 (7DH)	OMNI ON	0		o	o	o	o	o	o	o	o	
			126 (7EH)	MONO	0~16 (...10H)		o	x	x	x	x	x	x	x	
127 (7FH)	POLY	0		o	x	x	x	x	x	x	x				
Program Change	CnH		pp	Voice number(0~127)	-	-	o	o	o	o	o	o	o		
Channel After Touch	DnH		vv		-	-	o	o	o	o	o	o	x		
Polyphonic After Tch	AnH		kk		vv		x	x	x	x	x	x	x		
Pich Bend Change	EnH		cc	LS Byte	dd	MS Byte	o	o	o	o	o	o	o		
RealTime Message	F8H	MIDI Clock	-		-		o	o	o	o	o	o	o		
	FAH	Start	-		-		o	o	o	o	o	o	o		
	FBH	Continue	-		-		x	x	x	x	x	x	x		
	FCH	Stop	-		-		o	o	o	o	o	o	o		
	FEH	Active Sens	-		-		o	o	o	o	o	o	o		
FFH	System Reset	-		-			x	x	x	x	x	x	x		

The NRPN also contains these parameters.

MIDI Data Format/MIDI-Datenformat/Format de données MIDI

<Table 1-1-1> NRPN

o : available

NRPN		DATA ENTRY		Parameter	Recognized						
MSB	LSB	MSB	LSB		XG/GM	Keyboard	R1	R2	R3	Left	Acmp
01H	08H	mmH	--	Vibrato Rate	o	x	o	o	o	o	o
01H	09H	mmH	--	Vibrato Depth	o	x	o	o	o	o	o
01H	0AH	mmH	--	Vibrato Delay	o	x	x	x	x	x	o
01H	20H	mmH	--	Filter Cutoff Frequency	o	x	x	x	x	x	o
01H	21H	mmH	--	Filter Resonance	o	x	x	x	x	x	o
01H	24H	mmH	--	HPF Cutoff Frequency	x	x	x	x	x	x	x
01H	30H	mmH	--	EQ BASS	o	x	x	x	x	x	o
01H	31H	mmH	--	EQ TREBLE	o	x	x	x	x	x	o
01H	34H	mmH	--	EQ BASS Frequency	o	x	x	x	x	x	o
01H	35H	mmH	--	EQ TREBLE Frequency	o	x	x	x	x	x	o
01H	63H	mmH	--	EG Attack Time	o	x	x	x	x	x	o
01H	64H	mmH	--	EG Decay Time	o	x	x	x	x	x	o
01H	66H	mmH	--	EG Release	o	x	x	x	x	x	o
14H	rrH	mmH	--	Drum Filter Cutoff Frequency	o	x	x	x	x	x	o
15H	rrH	mmH	--	Drum Filter Resonance	o	x	x	x	x	x	o
16H	rrH	mmH	--	Drum EG Attack Rate	o	x	x	x	x	x	o
17H	rrH	mmH	--	Drum EG Decay Rate	o	x	x	x	x	x	o
18H	rrH	mmH	--	Drum Pitch Coarse	o	x	x	x	x	x	o
19H	rrH	mmH	--	Drum Pitch Fine	o	x	x	x	x	x	o
1AH	rrH	mmH	--	Drum Level	o	x	x	x	x	x	o
1CH	rrH	mmH	--	Drum Pan	o	x	x	x	x	x	o
1DH	rrH	mmH	--	Drum Reverb Send Level	o	x	x	x	x	x	o
1EH	rrH	mmH	--	Drum Chorus Send Level	o	x	x	x	x	x	o
1FH	rrH	mmH	--	Drum Variation Send Level	o	x	x	x	x	x	o

NRPN MSB : 14H-1FH(for drums) message is accepted as long as the channel is set with a drum voice.
Data Entry LSB : Ignored.

<Table 1-1-2> NRPN (VocalHarmony)

NRPN		DATA ENTRY		Parameter	Recognized						
MSB	LSB	MSB	LSB		XG/GM	Keyboard	R1	R2	R3	Left	Acmp
00H	00H	mmH	--	Harmony Mute	o	x	x	x	x	x	x
00H	01H	mmH	--	Harmony Mode	o	x	x	x	x	x	x
00H	02H	mmH	--	Vocoder Mode Parameter	o	x	x	x	x	x	x
00H	03H	mmH	--	Chromatic Mode Parameter	o	x	x	x	x	x	x
00H	04H	mmH	--	Detune Mode Parameter	o	x	x	x	x	x	x
00H	05H	mmH	--	Chordal Mode Parameter	o	x	x	x	x	x	x
01H	1AH	mmH	--	Detune Modulation	o	x	x	x	x	x	x
02H	00H	mmH	--	Harmony Gender Type	o	x	x	x	x	x	x
02H	01H	mmH	--	Auto Upper Gender Threshold	o	x	x	x	x	x	x
02H	02H	mmH	--	Auto Lower Gender Threshold	o	x	x	x	x	x	x
02H	03H	mmH	--	Upper Gender Amount	o	x	x	x	x	x	x
02H	04H	mmH	--	Lower Gender Amount	o	x	x	x	x	x	x
02H	10H	mmH	--	Harmony1 Volume	o	x	x	x	x	x	x
02H	11H	mmH	--	Harmony2 Volume	o	x	x	x	x	x	x
02H	12H	mmH	--	Harmony3 Volume	o	x	x	x	x	x	x
02H	20H	mmH	--	Harmony1 Pan	o	x	x	x	x	x	x
02H	21H	mmH	--	Harmony2 Pan	o	x	x	x	x	x	x
02H	22H	mmH	--	Harmony3 Pan	o	x	x	x	x	x	x
02H	30H	mmH	--	Harmony1 Detune	o	x	x	x	x	x	x
02H	31H	mmH	--	Harmony2 Detune	o	x	x	x	x	x	x
02H	32H	mmH	--	Harmony3 Detune	o	x	x	x	x	x	x
03H	00H	mmH	--	Lead Gender Type	o	x	x	x	x	x	x
03H	01H	mmH	--	Lead Gender Amount	o	x	x	x	x	x	x

<Table 1-2> RPN

RPN		DATA ENTRY		Parameter	Recognized						
MSB	LSB	MSB	LSB		XG/GM	Keyboard	R1	R2	R3	Left	Acmp
00H	00H	mmH	--	Pitch Bend Sensitivity	o	o	o	o	o	o	o
00H	01H	mmH	llH	Fine Tune	o	o	o	o	o	o	o
00H	02H	mmH	--	Coarse Tune	o	o	o	o	o	o	o
7FH	7FH	--	--	Null	o	o	o	o	o	o	o

System Exclusive Messages/ Systemexklusive Meldungen/ Messages exclusifs au système

System Exclusive Messages

Accompaniment Control	Data Format	Recognized
Section Control	<p>F0H 43H 7EH 00H ss dd F7H</p> <pre> 11110000 F0 = Exclusive status 01000011 43 = YAMAHA ID 01111110 7E = Style 00000000 00 = 0sssssss ss = Switch No. 00H-01H: INTRO II 02H-03H: INTRO III 04H-07H: INTRO I 08H: MAIN A 09H: MAIN B 0AH: MAIN C 0BH-0FH: MAIN D 10H: FILL IN A 11H: FILL IN B 12H: FILL IN C 13H-17H: FILL IN D 18H: BREAK FILL A 19H: BREAK FILL B 1AH: BREAK FILL C 1BH-1FH: BREAK FILL D 20H-21H: ENDING II 22H-23H: ENDING III 24H-27H: ENDING I 0ddddddd dd = Swith On/Off 00H Off 7FH On 11111110 F7 = End of Exclusive </pre>	o
Tempo Control	<p>F0H 43H 7EH 01H t4 t3 t2 t1 F7H</p> <pre> 11110000 F0 = Exclusive status 01000011 43 = YAMAHA ID 01111110 7E = Style 00000001 01 = 0ttttttt t4 = tempo4 0ttttttt t3 = tempo3 0ttttttt t2 = tempo2 0ttttttt t1 = tempo1 11111110 F7 = End of Exclusive </pre>	o
Chord Control	<p>F0H 43H 7EH tt dd ... F7H</p> <p>Type1 (tt=02)</p> <pre> 11110000 F0 = Exclusive status 01000011 43 = YAMAHA ID 01111110 7E = Style 00000010 02 = type 1(tt) 0ddddddd dd = chord root(cr) 0ddddddd dd = chord type(ct) 0ddddddd dd = bass note(bn) 0ddddddd dd = bass type(bt) cr : Chord Root 0fffnnnn fff: b or #, nnnn: note(root) 0000nnnn 0n bbb 0fff0000 x0 reserved 0001nnnn 1n bb 0fff0001 x1 C 0010nnnn 2n b 0fff0010 x2 D 0011nnnn 3n natural 0fff0011 x3 E 0100nnnn 4n # 0fff0100 x4 F 0101nnnn 5n ## 0fff0101 x5 G 0110nnnn 6n ### 0fff0110 x6 A 0fff0111 x7 B ct : Chord Type 0 - 34,127 00000000 00 0 Maj 00010010 12 18 dim7 00000001 01 1 Maj6 00010011 13 19 7th 00000010 02 2 Maj7 00010100 14 20 7sus4 00000011 03 3 Maj7(#11) 00010101 15 21 7b5 00000100 04 4 Maj(9) 00010110 16 22 7(9) 00000101 05 5 Maj7(9) 00010111 17 23 7(#11) 00000110 06 6 Maj6(9) 00011000 18 24 7(13) 00000111 07 7 aug 00011001 19 25 7(b9) 00001000 08 8 min 00011010 1A 26 7(b13) 00001001 09 9 min6 00011011 1B 27 7(#9) 00001010 0A 10 min7 00011100 1C 28 Maj7aug 00001011 0B 11 min7b5 00011101 1D 29 7aug 00001100 0C 12 min(9) 00011110 1E 30 1+8 00001101 0D 13 min7(9) 00011111 1F 31 1+5 00001110 0E 14 min7(11) 00100000 20 32 sus4 00001111 0F 15 minMaj7 00100001 21 33 1+2+5 00010000 10 16 minMaj7(9) 00100010 22 34 cc 00010001 11 17 dim </pre> <p>bn : On Bass Chord Same as Chord root, 127:No bass chord</p> <p>bt : Bass Chord Same as Chord type 127:No bass chord</p> <p>11111110 F7 = End of Exclusive</p>	o

MIDI Data Format/MIDI-Datenformat/Format de données MIDI

	Type2 (tt=03) (Receive only) 11110000 F0 = Exclusive status 01000011 43 = YAMAHA ID 01111110 7E = 00000011 03 = type 2(tt) 0ddddddd dd = note1 0ddddddd dd = note2 0ddddddd dd = note3 : : 0ddddddd dd = ...note10 11111110 F7 = End of Exclusive	o
--	--	---

System Exclusive Messages (Universal System Exclusive)

MIDI Event	Data Format	Recognized
MIDI Master Volume	F0H 7FH 7FH 04H 01H ll mm F7H 11110000 F0 = Exclusive status 01111111 7F = Universal Real Time 01111111 7F = ID of target device 00000100 04 = Sub-ID #1=Device Control Message 00000001 01 = Sub-ID #2=Master Volume 01111111 ll = Volume LSB 0mmmmmmm mm = Volume MSB 11110111 F7 = End of Exclusive or F0H 7FH XN 04H 01H ll mm F7H 11110000 F0 = Exclusive status 01111111 7F = Universal Real Time 0xxxnnnn XN = When N is received N=0-F, whichever is received. X=ignored 00000100 04 = Sub-ID #1=Device Control Message 00000001 01 = Sub-ID #2=Master Volume 01111111 ll = Volume LSB 0mmmmmmm mm = Volume MSB 11110111 F7 = End of Exclusive	o
GM System On	F0H 7EH 7FH 09H 01H F7H 11110000 F0 = Exclusive status 01111110 7E = Universal Non-Real Time 01111111 7F = ID of target device 00001001 09 = Sub-ID #1=General MIDI Message 00000001 01 = Sub-ID #2=General MIDI On 11110111 F7 = End of Exclusive or F0H 7EH XN 09H 01H F7H 11110000 F0 = Exclusive status 01111110 7E = Universal Non-Real Time 0xxxnnnn XN = When N is received N=0-F, whichever is received. X=ignored 00001001 09 = Sub-ID #1=General MIDI Message 00000001 01 = Sub-ID #2=General MIDI On 11110111 F7 = End of Exclusive	o

System Exclusive Messages (XG standard)

MIDI Event	Data Format	Recognized
XG Parameter Change	F0H 43H 1nH 4CH hh mm ll dd ... F7H 11110000 F0 = Exclusive status 01000011 43 = YAMAHA ID 0001nnnn 1n = Device Number n=always 0(when transmit), n=0-F(when receive) 01001100 4C = Model ID 0hhhhhhh hh = Address High 0mmmmmmm mm = Address Mid 0lllllll ll = Address Low 0ddddddd dd = Data : : 11110111 F7 = End of Exclusive	o
Bulk Dump	F0H 43H 0nH 4CH aa bb hh mm ll dd ... dd cc F7H 11110000 F0 = Exclusive status 01000011 43 = YAMAHA ID 0000nnnn 0n = Device Number n=always 0(when transmit), n=0-F(when receive) 01001100 4C = Model ID 0aaaaaaa aa = Byte Count MSB 0bbbbbbb bb = Byte Count LSB 0hhhhhhh hh = Address High 0mmmmmmm mm = Address Mid 0lllllll ll = Address Low 0ddddddd dd = Data : : 0ddddddd dd = Data 0ccccccc cc = Checksum 11110111 F7 = End of Exclusive	o

MIDI Data Format/MIDI-Datenformat/Format de données MIDI

Parameter Request	F0H 43H 3nH 4CH hh mm ll F7H		
	11110000	F0	= Exclusive status
	01000011	43	= YAMAHA ID
	0011nnnn	3n	= Device Number n=always 0(when transmit), n=0-F(when receive)
	01001100	4C	= Model ID
	0hhhhhhh	hh	= Address High
	0mmmmmm	mm	= Address Mid
	01111111	ll	= Address Low
11110111	F7	= End of Exclusive	o
Dump Request	F0H 43H 2nH 4CH hh mm ll F7H		
	11110000	F0	= Exclusive status
	01000011	43	= YAMAHA ID
	0010nnnn	2n	= Device Number n=always 0(when transmit), n=0-F(when receive)
	01001100	4C	= Model ID
	0hhhhhhh	hh	= Address High
	0mmmmmm	mm	= Address Mid
	01111111	ll	= Address Low
11110111	F7	= End of Exclusive	o

System Exclusive Messages (Clavinova compliance)

MIDI Event	Data Format	Recognized																																																																																																															
Internal Clock	F0H 43H 73H 01H 02H F7H	o																																																																																																															
	00000010 02 = Internal Clock Substatus																																																																																																																
External Clock	F0H 43H 73H 01H 03H F7H	o																																																																																																															
	00000011 03 = External Clock Substatus																																																																																																																
Organ Flutes data Bulk Dump	F0H 43H 73H 01H 06H 0BH 00H 00H 01H 06H 0nH [BULK DATA] sum F7H	o																																																																																																															
	<table style="width: 100%; border-collapse: collapse;"> <tr> <td style="width: 15%;">01H</td> <td style="width: 35%;">Model ID (Clavinova common ID)</td> <td style="width: 15%;"></td> <td style="width: 35%;"></td> </tr> <tr> <td>06H</td> <td>Bulk ID</td> <td></td> <td></td> </tr> <tr> <td>0BH</td> <td>Bulk No. (Organ Flutes data Bulk Dump)</td> <td></td> <td></td> </tr> <tr> <td>00H,00H,01H,06H</td> <td>Data Length :16bytes</td> <td></td> <td></td> </tr> <tr> <td>1st 0nH</td> <td>n: channel No.</td> <td></td> <td></td> </tr> <tr> <td>[BULK DATA]</td> <td>Organ Flutes data</td> <td></td> <td></td> </tr> <tr> <td>2nd Footage</td> <td>[1] 00 - 07H</td> <td>data: 0: -∞, 1: -12, 2: -9, 3: -6, 4: -4.5,</td> <td></td> </tr> <tr> <td>3rd</td> <td>[1 1/3'] 00 - 07H</td> <td>5: -3, 6: -1.5: 7: 0[dB]</td> <td></td> </tr> <tr> <td>4th</td> <td>[1 3/5'] 00 - 09H</td> <td></td> <td></td> </tr> <tr> <td>5th</td> <td>[2] 00 - 07H</td> <td></td> <td></td> </tr> <tr> <td>6th</td> <td>[2 2/3'] 00 - 07H</td> <td></td> <td></td> </tr> <tr> <td>7th</td> <td>[4] 00 - 07H</td> <td></td> <td></td> </tr> <tr> <td>8th</td> <td>[5 1/3'] 00 - 07H</td> <td></td> <td></td> </tr> <tr> <td>9th</td> <td>[8] 00 - 07H</td> <td></td> <td></td> </tr> <tr> <td>10th</td> <td>[16'] 00 - 07H</td> <td></td> <td></td> </tr> <tr> <td>11th</td> <td>[Attack 2'] 00 - 07H</td> <td></td> <td></td> </tr> <tr> <td>12th</td> <td>[Attack 2 2/3'] 00 - 07H</td> <td></td> <td></td> </tr> <tr> <td>13th</td> <td>[Attack 4'] 00 - 07H</td> <td></td> <td></td> </tr> <tr> <td>14th Settings</td> <td>[Attack Length] 00 - 07H</td> <td></td> <td></td> </tr> <tr> <td>15th</td> <td>[Response] 00 - 07H</td> <td></td> <td></td> </tr> <tr> <td>16th</td> <td>[Attack Mode] 00 - 01H</td> <td>00H: Each, 01H: First</td> <td></td> </tr> <tr> <td>17th</td> <td>[Wave Variation] 00 - 01H</td> <td>00H: Sine, 01H: Tone Wheel</td> <td></td> </tr> <tr> <td>18th</td> <td>[Volume] 00 - 07H</td> <td></td> <td></td> </tr> <tr> <td>19th</td> <td>[aux 4] 00H</td> <td></td> <td></td> </tr> <tr> <td>20th</td> <td>[aux 5] 00H</td> <td></td> <td></td> </tr> <tr> <td>21th</td> <td>[aux 6] 00H</td> <td></td> <td></td> </tr> <tr> <td>22th</td> <td>[aux 7] 00H</td> <td></td> <td></td> </tr> <tr> <td></td> <td>sum</td> <td>Check Sum = 0-sum(BULK DATA)</td> <td></td> </tr> </table>	01H	Model ID (Clavinova common ID)			06H	Bulk ID			0BH	Bulk No. (Organ Flutes data Bulk Dump)			00H,00H,01H,06H	Data Length :16bytes			1st 0nH	n: channel No.			[BULK DATA]	Organ Flutes data			2nd Footage	[1] 00 - 07H	data: 0: -∞, 1: -12, 2: -9, 3: -6, 4: -4.5,		3rd	[1 1/3'] 00 - 07H	5: -3, 6: -1.5: 7: 0[dB]		4th	[1 3/5'] 00 - 09H			5th	[2] 00 - 07H			6th	[2 2/3'] 00 - 07H			7th	[4] 00 - 07H			8th	[5 1/3'] 00 - 07H			9th	[8] 00 - 07H			10th	[16'] 00 - 07H			11th	[Attack 2'] 00 - 07H			12th	[Attack 2 2/3'] 00 - 07H			13th	[Attack 4'] 00 - 07H			14th Settings	[Attack Length] 00 - 07H			15th	[Response] 00 - 07H			16th	[Attack Mode] 00 - 01H	00H: Each, 01H: First		17th	[Wave Variation] 00 - 01H	00H: Sine, 01H: Tone Wheel		18th	[Volume] 00 - 07H			19th	[aux 4] 00H			20th	[aux 5] 00H			21th	[aux 6] 00H			22th	[aux 7] 00H				sum	Check Sum = 0-sum(BULK DATA)	
01H	Model ID (Clavinova common ID)																																																																																																																
06H	Bulk ID																																																																																																																
0BH	Bulk No. (Organ Flutes data Bulk Dump)																																																																																																																
00H,00H,01H,06H	Data Length :16bytes																																																																																																																
1st 0nH	n: channel No.																																																																																																																
[BULK DATA]	Organ Flutes data																																																																																																																
2nd Footage	[1] 00 - 07H	data: 0: -∞, 1: -12, 2: -9, 3: -6, 4: -4.5,																																																																																																															
3rd	[1 1/3'] 00 - 07H	5: -3, 6: -1.5: 7: 0[dB]																																																																																																															
4th	[1 3/5'] 00 - 09H																																																																																																																
5th	[2] 00 - 07H																																																																																																																
6th	[2 2/3'] 00 - 07H																																																																																																																
7th	[4] 00 - 07H																																																																																																																
8th	[5 1/3'] 00 - 07H																																																																																																																
9th	[8] 00 - 07H																																																																																																																
10th	[16'] 00 - 07H																																																																																																																
11th	[Attack 2'] 00 - 07H																																																																																																																
12th	[Attack 2 2/3'] 00 - 07H																																																																																																																
13th	[Attack 4'] 00 - 07H																																																																																																																
14th Settings	[Attack Length] 00 - 07H																																																																																																																
15th	[Response] 00 - 07H																																																																																																																
16th	[Attack Mode] 00 - 01H	00H: Each, 01H: First																																																																																																															
17th	[Wave Variation] 00 - 01H	00H: Sine, 01H: Tone Wheel																																																																																																															
18th	[Volume] 00 - 07H																																																																																																																
19th	[aux 4] 00H																																																																																																																
20th	[aux 5] 00H																																																																																																																
21th	[aux 6] 00H																																																																																																																
22th	[aux 7] 00H																																																																																																																
	sum	Check Sum = 0-sum(BULK DATA)																																																																																																															
DOC Multi Timbre OFF	F0H 43H 73H 01H 13H F7H	o																																																																																																															
DOC Multi Timbre ON	F0H 43H 73H 01H 14H F7H																																																																																																																
	00010011 13 = DOC Multi Timbre OFF Substatus																																																																																																																
	00010100 14 = DOC Multi Timbre ON Substatus																																																																																																																
	When the DOC Multi Timbre ON is accepted, the MIDI receive mode is set as listed below :																																																																																																																
	Channel No Part																																																																																																																
	1~10 Manual Part (Melody Part)																																																																																																																
	15 Rhythm																																																																																																																
	16 Control (Including the System Exclusive messages.)																																																																																																																
MIDI FA Cancel	F0H 43H 73H 01H 61H F7H	x																																																																																																															
	01100001 61 = MIDI FA Cancel Substatus																																																																																																																
MIDI FA Cancel Off	F0H 43H 73H 01H 62H F7H	x																																																																																																															
	01100010 62 = MIDI FA Cancel Off Substatus																																																																																																																

System Exclusive Messages Special Operators

MIDI Event	Data Format	Recognized
Volume & Expression & Pan Realtime control off (Voice Reserve)	F0H 43H 73H 01H 11H 0nH 45H dd F7H	o
	0000nnnn 0n = Channel No.(00H-0FH)	
	01000101 45 = Volume & Expression Control No.	
	0ddddddd dd = Value (Available only for the specified channel)	
	00H : Realtime On	
	7FH : Realtime Off	

MIDI Data Format/MIDI-Datenformat/Format de données MIDI

System Exclusive Messages Special Operators (Vocal Harmony Additional Parameters)

MIDI Event	Data Format	Recognized
Vocal Harmony Pitch to Note ON/OFF	F0H 43H 73H 01H 11H 00H 50H 00H ss F7H 00000000 00 = Channel No.(always 00) 01010000 50 = Vocal Harmony Additional Parameter Control No. 00000000 00 = Pitch to Note Parameter No. 0sssssss ss = Pitch To Note Switch 00H: Off 01H: On	o
Vocal Harmony Pitch to Note Part	F0H 43H 73H 01H 11H 00H 50H 01H ss F7H 00000000 00 = Channel No.(always 00) 01010000 50 = Vocal Harmony Additional Parameter Control No. 00000001 01 = Pitch to Note Part Parameter No. 0sssssss ss = Pitch To Note Part No. 00H: RIGHT1 01H: RIGHT2 02H: LEFT 03H: LEAD 04H: UPPER	o
Vocal Harmony Vocoder Part (Harmony Part(Panel))	F0H 43H 73H 01H 11H 00H 50H 10H ss F7H 00000000 00 = Channel No.(always 00) 01010000 50 = Vocal Harmony Additional Parameter Control No. 00010000 10 = Vocoder Part Parameter No. 0sssssss ss = Harmony Part No. 00H: Off 01H: Upper 02H: Lower	o
Vocal Harmony Additional Reverb Depth	F0H 43H 73H 01H 11H 00H 50H 11H ss F7H 00000000 00 = Channel No.(always 00) 01010000 50 = Vocal Harmony Additional Parameter Control No. 00010001 11 = Vocal Harmony Additional Reverb Depth Parameter No. 0sssssss ss = Value(0...7FH)	x
Vocal Harmony Additional Chorus Depth	F0H 43H 73H 01H 11H 00H 50H 12H ss F7H 00000000 00 = Channel No.(always 00) 01010000 50 = Vocal Harmony Additional Parameter Control No. 00010010 12 = Vocal Harmony Additional Chorus Depth Parameter No. 0sssssss ss = Value(0...7FH)	x
Vocal Harmony Panel Variation LED On/Off	F0H 43H 73H 01H 11H 00H 50H 13H ss F7H 00000000 00 = Channel No.(always 00) 01010000 50 = Vocal Harmony Additional Parameter Control No. 00010011 13 = Vocal Harmony Panel Variation LED On/Off Parameter No. 0sssssss ss = Switch On/Off 00H: Variation LED Off 7FH: Variation LED On	x

System Exclusive Messages (the other)

MIDI Event	Data Format	Recognized
MIDI Master Tuning	F0H 43H 1nH 27H 30H 00H 00H mm ll cc F7H 11110000 F0 = Exclusive status 01000011 43 = YAMAHA 0001nnnn 1n n= always 0(when transmit), n=0-F(when receive) 00100111 27 = sub ID 00110000 30 = sub ID 00000000 00 00000000 00 0mmmmmmmm mm = Master Tune MSB 01111111 ll = Master Tune LSB 0ccccccc cc ignored 11110111 F7 = End of Exclusive	o
MWCAT parameter flag	F0H 43H 73H 01H 11H 0nH 54H dd F7H 0000nnnn 0n = Sequencer Track No. 01010100 54 = MWCAT parameter flag 0ddddddd dd = Value (ignored)	o

MIDI Parameter Change Table/ Änderungstabelle der MIDI-Parameter/ Tableau des changements de paramètres MIDI

<Table 3-1> MIDI PARAMETER CHANGE TABLE (SYSTEM)

Address (H)	Size (H)	Data (H)	Parameter	Recognized	Description	Default value(H)
0 0 0 1 2 3	4	0000 - 07FF	MASTER TUNE	o	-102.4 - +102.3[cent] 1st bit3-0→bit15-12 2nd bit3-0→bit11-8 3rd bit3-0→bit7-4 4th bit3-0→bit3-0	00 04 00 00
4	1	00 - 7F	MASTER VOLUME	o	0 - 127	7F
5	1		(MASTER ATTENUATOR)	x	—	
6	1	28 - 58	TRANSPOSE	o	-24 - +24[semitones]	40
7D	n		DRUM SETUP RESET	o	n=Drum setup number	
7E	0		XG SYSTEM ON	o	00=XG system ON	
7F	0		ALL PARAMETER RESET	o	00=ON	

TOTAL SIZE 7

<Table 3-2> MIDI PARAMETER CHANGE TABLE (System information)

Address (H)	Size (H)	Data (H)	Parameter	Recognized	Description	Default
1 0 0 : 0D	E	20 - 7F	Model Name	x	32-127(ASCII)	
0E	1	0				0
0F	1	0				0

TOTAL SIZE 10

Transmitted by Dump Request. Not Received.

<Table 3-3> MIDI PARAMETER CHANGE TABLE (EFFECT 1)

Address (H)	Size (H)	Data (H)	Parameter	Recognized	Description	Default
2 1 0	2	00-7F	REVERB TYPE MSB	o	Refer to the MIDI EFFECT MAP	01(=HALL1)
		00-7F	REVERB TYPE LSB		00 : basic type	00
2	1	00-7F	REVERB PARAMETER 1	o	Refer to the MIDI EFFECT PARAMETER LIST	depends on reverb type
3	1	00-7F	REVERB PARAMETER 2	o	Refer to the MIDI EFFECT PARAMETER LIST	depends on reverb type
4	1	00-7F	REVERB PARAMETER 3	o	Refer to the MIDI EFFECT PARAMETER LIST	depends on reverb type
5	1	00-7F	REVERB PARAMETER 4	o	Refer to the MIDI EFFECT PARAMETER LIST	depends on reverb type
6	1	00-7F	REVERB PARAMETER 5	o	Refer to the MIDI EFFECT PARAMETER LIST	depends on reverb type
7	1	00-7F	REVERB PARAMETER 6	o	Refer to the MIDI EFFECT PARAMETER LIST	depends on reverb type
8	1	00-7F	REVERB PARAMETER 7	o	Refer to the MIDI EFFECT PARAMETER LIST	depends on reverb type
9	1	00-7F	REVERB PARAMETER 8	o	Refer to the MIDI EFFECT PARAMETER LIST	depends on reverb type
0A	1	00-7F	REVERB PARAMETER 9	o	Refer to the MIDI EFFECT PARAMETER LIST	depends on reverb type
0B	1	00-7F	REVERB PARAMETER 10	o	Refer to the MIDI EFFECT PARAMETER LIST	depends on reverb type
0C	1	00-7F	REVERB RETURN	o	∞dB...0dB...+6dB(0...64...127)	40
0D	1	01-7F	REVERB PAN	o	L63...C...R63(1...64...127)	40

TOTAL SIZE 0E

2 1 10	1	00-7F	REVERB PARAMETER 11	o	Refer to the MIDI EFFECT PARAMETER LIST	depends on reverb type
11	1	00-7F	REVERB PARAMETER 12	o	Refer to the MIDI EFFECT PARAMETER LIST	depends on reverb type
12	1	00-7F	REVERB PARAMETER 13	o	Refer to the MIDI EFFECT PARAMETER LIST	depends on reverb type
13	1	00-7F	REVERB PARAMETER 14	o	Refer to the MIDI EFFECT PARAMETER LIST	depends on reverb type
14	1	00-7F	REVERB PARAMETER 15	o	Refer to the MIDI EFFECT PARAMETER LIST	depends on reverb type
15	1	00-7F	REVERB PARAMETER 16	o	Refer to the MIDI EFFECT PARAMETER LIST	depends on reverb type

TOTAL SIZE 6

2 1 20	2	00-7F	CHORUS TYPE MSB	o	Refer to the MIDI EFFECT MAP	41(=CHORUS1)
		00-7F	CHORUS TYPE LSB		00 : basic type	00
22	1	00-7F	CHORUS PARAMETER 1	o	Refer to the MIDI EFFECT PARAMETER LIST	depends on chorus Type
23	1	00-7F	CHORUS PARAMETER 2	o	Refer to the MIDI EFFECT PARAMETER LIST	depends on chorus Type
24	1	00-7F	CHORUS PARAMETER 3	o	Refer to the MIDI EFFECT PARAMETER LIST	depends on chorus Type
25	1	00-7F	CHORUS PARAMETER 4	o	Refer to the MIDI EFFECT PARAMETER LIST	depends on chorus Type
26	1	00-7F	CHORUS PARAMETER 5	o	Refer to the MIDI EFFECT PARAMETER LIST	depends on chorus Type
27	1	00-7F	CHORUS PARAMETER 6	o	Refer to the MIDI EFFECT PARAMETER LIST	depends on chorus Type
28	1	00-7F	CHORUS PARAMETER 7	o	Refer to the MIDI EFFECT PARAMETER LIST	depends on chorus Type
29	1	00-7F	CHORUS PARAMETER 8	o	Refer to the MIDI EFFECT PARAMETER LIST	depends on chorus Type
2A	1	00-7F	CHORUS PARAMETER 9	o	Refer to the MIDI EFFECT PARAMETER LIST	depends on chorus Type
2B	1	00-7F	CHORUS PARAMETER 10	o	Refer to the MIDI EFFECT PARAMETER LIST	depends on chorus Type
2C	1	00-7F	CHORUS RETURN	o	∞dB...0dB...+6dB(0...64...127)	40
2D	1	01-7F	CHORUS PAN	o	L63...C...R63(1...64...127)	40
2E	1	00-7F	SEND CHORUS TO REVERB	o	∞dB...0dB...+6dB(0...64...127)	00

TOTAL SIZE 0F

2 1 30	1	00-7F	CHORUS PARAMETER 11	o	Refer to the MIDI EFFECT PARAMETER LIST	depends on chorus Type
31	1	00-7F	CHORUS PARAMETER 12	o	Refer to the MIDI EFFECT PARAMETER LIST	depends on chorus Type
32	1	00-7F	CHORUS PARAMETER 13	o	Refer to the MIDI EFFECT PARAMETER LIST	depends on chorus Type
33	1	00-7F	CHORUS PARAMETER 14	o	Refer to the MIDI EFFECT PARAMETER LIST	depends on chorus Type
34	1	00-7F	CHORUS PARAMETER 15	o	Refer to the MIDI EFFECT PARAMETER LIST	depends on chorus Type
35	1	00-7F	CHORUS PARAMETER 16	o	Refer to the MIDI EFFECT PARAMETER LIST	depends on chorus Type

TOTAL SIZE 6

MIDI Data Format/MIDI-Datenformat/Format de données MIDI

2	1	40	2	00-7F	VARIATION TYPE MSB	o	Refer to the MIDI EFFECT MAP	05(=DELAY L,C,R)
				00-7F	VARIATION TYPE LSB		00 : basic type	00
	42	2	00-7F	VARIATION PARAMETER 1 MSB	o	Refer to the MIDI EFFECT PARAMETER LIST	depends on variation type	
			00-7F	VARIATION PARAMETER 1 LSB		Refer to the MIDI EFFECT PARAMETER LIST	depends on variation type	
	44	2	00-7F	VARIATION PARAMETER 2 MSB	o	Refer to the MIDI EFFECT PARAMETER LIST	depends on variation type	
			00-7F	VARIATION PARAMETER 2 LSB		Refer to the MIDI EFFECT PARAMETER LIST	depends on variation type	
	46	2	00-7F	VARIATION PARAMETER 3 MSB	o	Refer to the MIDI EFFECT PARAMETER LIST	depends on variation type	
			00-7F	VARIATION PARAMETER 3 LSB		Refer to the MIDI EFFECT PARAMETER LIST	depends on variation type	
	48	2	00-7F	VARIATION PARAMETER 4 MSB	o	Refer to the MIDI EFFECT PARAMETER LIST	depends on variation type	
			00-7F	VARIATION PARAMETER 4 LSB		Refer to the MIDI EFFECT PARAMETER LIST	depends on variation type	
	4A	2	00-7F	VARIATION PARAMETER 5 MSB	o	Refer to the MIDI EFFECT PARAMETER LIST	depends on variation type	
			00-7F	VARIATION PARAMETER 5 LSB		Refer to the MIDI EFFECT PARAMETER LIST	depends on variation type	
	4C	2	00-7F	VARIATION PARAMETER 6 MSB	o	Refer to the MIDI EFFECT PARAMETER LIST	depends on variation type	
			00-7F	VARIATION PARAMETER 6 LSB		Refer to the MIDI EFFECT PARAMETER LIST	depends on variation type	
	4E	2	00-7F	VARIATION PARAMETER 7 MSB	o	Refer to the MIDI EFFECT PARAMETER LIST	depends on variation type	
			00-7F	VARIATION PARAMETER 7 LSB		Refer to the MIDI EFFECT PARAMETER LIST	depends on variation type	
	50	2	00-7F	VARIATION PARAMETER 8 MSB	o	Refer to the MIDI EFFECT PARAMETER LIST	depends on variation type	
			00-7F	VARIATION PARAMETER 8 LSB		Refer to the MIDI EFFECT PARAMETER LIST	depends on variation type	
	52	2	00-7F	VARIATION PARAMETER 9 MSB	o	Refer to the MIDI EFFECT PARAMETER LIST	depends on variation type	
			00-7F	VARIATION PARAMETER 9 LSB		Refer to the MIDI EFFECT PARAMETER LIST	depends on variation type	
	54	2	00-7F	VARIATION PARAMETER 10 MSB	o	Refer to the MIDI EFFECT PARAMETER LIST	depends on variation type	
			00-7F	VARIATION PARAMETER 10 LSB		Refer to the MIDI EFFECT PARAMETER LIST	depends on variation type	
	56	1	00-7F	VARIATION RETURN	o	--dB...0dB...+6dB(0...64...127)	40	
	57	1	01-7F	VARIATION PAN	o	L63...C...R63(1...64...127)	40	
	58	1	00-7F	SEND VARIATION TO REVERB	o	--dB...0dB...+6dB(0...64...127)	00	
	59	1	00-7F	SEND VARIATION TO CHORUS	o	--dB...0dB...+6dB(0...64...127)	00	
	5A	1	00-01	VARIATION CONNECTION	o	0:INSERTION,1:SYSTEM	00	
	5B	1	00-7F	VARIATION PART	o	Part1...16(0...15) AD1(64) OFF(16...63, 65...127)	7F	
	5C	1		MW VARIATION CONTROL DEPTH	o	-64 - +63	40	
	5D	1		BEND VARIATION CONTROL DEPTH	o	-64 - +63	40	
	5E	1		CAT VARIATION CONTROL DEPTH	o	-64 - +63	40	
	5F	1		AC1 VARIATION CONTROL DEPTH	x	-64 - +63	40	
	60	1		AC2 VARIATION CONTROL DEPTH	x	-64 - +63	40	

TOTAL SIZE 21

2	1	70	1	00-7F	VARIATION PARAMETER 11	o	Refer to the MIDI EFFECT PARAMETER LIST	depends on variation type
	71	1	00-7F	VARIATION PARAMETER 12	o	Refer to the MIDI EFFECT PARAMETER LIST	depends on variation type	
	72	1	00-7F	VARIATION PARAMETER 13	o	Refer to the MIDI EFFECT PARAMETER LIST	depends on variation type	
	73	1	00-7F	VARIATION PARAMETER 14	o	Refer to the MIDI EFFECT PARAMETER LIST	depends on variation type	
	74	1	00-7F	VARIATION PARAMETER 15	o	Refer to the MIDI EFFECT PARAMETER LIST	depends on variation type	
	75	1	00-7F	VARIATION PARAMETER 16	o	Refer to the MIDI EFFECT PARAMETER LIST	depends on variation type	

TOTAL SIZE 6

<Table 3-4> MIDI PARAMETER CHANGE TABLE (MASTER EQ)

Address (H)	Size (H)	Data (H)	Parameter	Recognized	Description	Default value(H)
2	40	0	00 - 04	EQ type	0:FLAT 1:JAZZ 2:POPS 3:ROCK 4:CLASSIC	0
1	1	34 -4C	EQ gain1	o	-12 - +12[dB]	40
2	1	04-28	EQ frequency1	o	32-2000[Hz]	0C
3	1	01-78	EQ Q1	o	0.1-12.0	7
4	1	00-01	EQ shape1	o	00:shelving, 01:peaking	0
5	1	34 -4C	EQ gain2	o	-12 - +12[dB]	40
6	1	0E-36	EQ frequency2	o	100-10.0[kHz]	1C
7	1	01-78	EQ Q2	o	0.1-12.0	7
8	1		not used	x		
9	1	34 -4C	EQ gain3	o	-12 - +12[dB]	40
0A	1	0E-36	EQ frequency3	o	100-10.0[kHz]	22
0B	1	01-78	EQ Q3	o	0.1-12.0	7
0C	1		not used	x		
0D	1	34 -4C	EQ gain4	o	-12 - +12[dB]	40
0E	1	0E-36	EQ frequency4	o	100-10.0[kHz]	2E
0F	1	01-78	EQ Q4	o	0.1-12.0	7
10	1		not used	x		
11	1	34 -4C	EQ gain5	o	-12 - +12[dB]	40
12	1	1C-3A	EQ frequency5	o	0.5-16.0[kHz]	34
13	1	01-78	EQ Q5	o	0.1-12.0	7
14	1	00-01	EQ shape5	o	00:shelving, 01:peaking	0

TOTAL SIZE 15

<Table 3-5> MIDI PARAMETER CHANGE TABLE (EFFECT 2)

Address (H)	Size (H)	Data (H)	Parameter	Recognized	Description	Default
3	0n	0	00-7F	INSERTION EFFECT n TYPE MSB	Refer to the MIDI EFFECT MAP	49(=DISTORTION)
			00-7F	INSERTION EFFECT n TYPE LSB	00 : basic type	00
	2	1	00-7F	INSERTION EFFECT n PARAMETER1	Refer to the MIDI EFFECT PARAMETER LIST	depends on insertion 1 type
	3	1	00-7F	INSERTION EFFECT n PARAMETER2	Refer to the MIDI EFFECT PARAMETER LIST	depends on insertion 1 type
	4	1	00-7F	INSERTION EFFECT n PARAMETER3	Refer to the MIDI EFFECT PARAMETER LIST	depends on insertion 1 type
	5	1	00-7F	INSERTION EFFECT n PARAMETER4	Refer to the MIDI EFFECT PARAMETER LIST	depends on insertion 1 type

MIDI Data Format/MIDI-Datenformat/Format de données MIDI

6	1	00-7F	INSERTION EFFECT n PARAMETER5	o	Refer to the MIDI EFFECT PARAMETER LIST	depends on insertion 1 type	
7	1	00-7F	INSERTION EFFECT n PARAMETER6	o	Refer to the MIDI EFFECT PARAMETER LIST	depends on insertion 1 type	
8	1	00-7F	INSERTION EFFECT n PARAMETER7	o	Refer to the MIDI EFFECT PARAMETER LIST	depends on insertion 1 type	
9	1	00-7F	INSERTION EFFECT n PARAMETER8	o	Refer to the MIDI EFFECT PARAMETER LIST	depends on insertion 1 type	
0A	1	00-7F	INSERTION EFFECT n PARAMETER9	o	Refer to the MIDI EFFECT PARAMETER LIST	depends on insertion 1 type	
0B	1	00-7F	INSERTION EFFECT n PARAMETER10	o	Refer to the MIDI EFFECT PARAMETER LIST	depends on insertion 1 type	
0C	1	00-7F	INSERTION EFFECT n PART	o	Part1...16(0...15) AD1(64) OFF(16...63, 65...127)	7F	
0D	1	00-7F	MW INSERTION CONTROL DEPTH	o	-64 - 63	40	
0E	1	00-7F	BEND INSERTION CONTROL DEPTH	o	-64 - 63	40	
0F	1	00-7F	CAT INSERTION CONTROL DEPTH	o	-64 - 63	40	
10	1	00-7F	AC1 INSERTION CONTROL DEPTH	x	-64 - 63	40	
11	1	00-7F	AC2 INSERTION CONTROL DEPTH	x	-64 - 63	40	
TOTAL SIZE		12					

20	1	00-7F	INSERTION EFFECT n PARAMETER11	o	Refer to the MIDI EFFECT PARAMETER LIST	depends on insertion 1 type	
21	1	00-7F	INSERTION EFFECT n PARAMETER12	o	Refer to the MIDI EFFECT PARAMETER LIST	depends on insertion 1 type	
22	1	00-7F	INSERTION EFFECT n PARAMETER13	o	Refer to the MIDI EFFECT PARAMETER LIST	depends on insertion 1 type	
23	1	00-7F	INSERTION EFFECT n PARAMETER14	o	Refer to the MIDI EFFECT PARAMETER LIST	depends on insertion 1 type	
24	1	00-7F	INSERTION EFFECT n PARAMETER15	o	Refer to the MIDI EFFECT PARAMETER LIST	depends on insertion 1 type	
25	1	00-7F	INSERTION EFFECT n PARAMETER16	o	Refer to the MIDI EFFECT PARAMETER LIST	depends on insertion 1 type	
TOTAL SIZE		6					

30	2	00 - 7F	INSERTION EFFECT n PARAMETER1 MSB	o	Refer to the XG EFFECT PARAMETER LIST	depends on insertion 1 type	
		00 - 7F	INSERTION EFFECT n PARAMETER1 LSB	o	Refer to the XG EFFECT PARAMETER LIST	depends on insertion 1 type	
32	2	00 - 7F	INSERTION EFFECT n PARAMETER2 MSB	o	Refer to the XG EFFECT PARAMETER LIST	depends on insertion 1 type	
		00 - 7F	INSERTION EFFECT n PARAMETER2 LSB	o	Refer to the XG EFFECT PARAMETER LIST	depends on insertion 1 type	
34	2	00 - 7F	INSERTION EFFECT n PARAMETER3 MSB	o	Refer to the XG EFFECT PARAMETER LIST	depends on insertion 1 type	
		00 - 7F	INSERTION EFFECT n PARAMETER3 LSB	o	Refer to the XG EFFECT PARAMETER LIST	depends on insertion 1 type	
36	2	00 - 7F	INSERTION EFFECT n PARAMETER4 MSB	o	Refer to the XG EFFECT PARAMETER LIST	depends on insertion 1 type	
		00 - 7F	INSERTION EFFECT n PARAMETER4 LSB	o	Refer to the XG EFFECT PARAMETER LIST	depends on insertion 1 type	
38	2	00 - 7F	INSERTION EFFECT n PARAMETER5 MSB	o	Refer to the XG EFFECT PARAMETER LIST	depends on insertion 1 type	
		00 - 7F	INSERTION EFFECT n PARAMETER5 LSB	o	Refer to the XG EFFECT PARAMETER LIST	depends on insertion 1 type	
3A	2	00 - 7F	INSERTION EFFECT n PARAMETER6 MSB	o	Refer to the XG EFFECT PARAMETER LIST	depends on insertion 1 type	
		00 - 7F	INSERTION EFFECT n PARAMETER6 LSB	o	Refer to the XG EFFECT PARAMETER LIST	depends on insertion 1 type	
3C	2	00 - 7F	INSERTION EFFECT n PARAMETER7 MSB	o	Refer to the XG EFFECT PARAMETER LIST	depends on insertion 1 type	
		00 - 7F	INSERTION EFFECT n PARAMETER7 LSB	o	Refer to the XG EFFECT PARAMETER LIST	depends on insertion 1 type	
3E	2	00 - 7F	INSERTION EFFECT n PARAMETER8 MSB	o	Refer to the XG EFFECT PARAMETER LIST	depends on insertion 1 type	
		00 - 7F	INSERTION EFFECT n PARAMETER8 LSB	o	Refer to the XG EFFECT PARAMETER LIST	depends on insertion 1 type	
40	2	00 - 7F	INSERTION EFFECT n PARAMETER9 MSB	o	Refer to the XG EFFECT PARAMETER LIST	depends on insertion 1 type	
		00 - 7F	INSERTION EFFECT n PARAMETER9 LSB	o	Refer to the XG EFFECT PARAMETER LIST	depends on insertion 1 type	
42	2	00 - 7F	INSERTION EFFECT n PARAMETER10 MSB	o	Refer to the XG EFFECT PARAMETER LIST	depends on insertion 1 type	
		00 - 7F	INSERTION EFFECT n PARAMETER10 LSB	o	Refer to the XG EFFECT PARAMETER LIST	depends on insertion 1 type	
TOTAL SIZE		14					

On: insertion effect number

Note : For effect types that do not require MSB, the Parameters for Address 02-0B will be received and the Parameters for Address 30-42 will not be received.
 For effect types that require MSB, the Parameters for Address 30-42 will be received and the Parameters for Address 02-0B will not be received.
 When Bulk Dumps that include Effect Type data are transmitted, the Parameters for Address 02 - 0B will always be transmitted. But, effects that require MSB, when the bulk dump is received the Parameters for Address 02 - 0B will not be received.
 The following four effect types require MSB:
 DelayLCR, DelayLR, Echo, CrossDelay, Dist+Delay, Comp+Dist+Delay, Wah+Dist+Delay, VDistortion
 *Data Range is different according to the Effect type value.

<Table 3-6> MIDI PARAMETER CHANGE TABLE (SPECIAL EFFECT)

Address (H)	Size (H)	Data (H)	Parameter	Recognized	Description	Default
04 00 00	2	00 - 7F	INSERTION EFFECT TYPE MSB	o	Refer to the XG EFFECT MAP 00 : basic type	49(=DISTORTION)
		00 - 7F	INSERTION EFFECT TYPE LSB	o		00
02	1	00 - 7F	INSERTION EFFECT PARAMETER1	o	Refer to the XG EFFECT PARAMETER LIST	depends on insertion 1 type
03	1	00 - 7F	INSERTION EFFECT PARAMETER2	o	Refer to the XG EFFECT PARAMETER LIST	depends on insertion 1 type
04	1	00 - 7F	INSERTION EFFECT PARAMETER3	o	Refer to the XG EFFECT PARAMETER LIST	depends on insertion 1 type
05	1	00 - 7F	INSERTION EFFECT PARAMETER4	o	Refer to the XG EFFECT PARAMETER LIST	depends on insertion 1 type
06	1	00 - 7F	INSERTION EFFECT PARAMETER5	o	Refer to the XG EFFECT PARAMETER LIST	depends on insertion 1 type
07	1	00 - 7F	INSERTION EFFECT PARAMETER6	o	Refer to the XG EFFECT PARAMETER LIST	depends on insertion 1 type
08	1	00 - 7F	INSERTION EFFECT PARAMETER7	o	Refer to the XG EFFECT PARAMETER LIST	depends on insertion 1 type
09	1	00 - 7F	INSERTION EFFECT PARAMETER8	o	Refer to the XG EFFECT PARAMETER LIST	depends on insertion 1 type
0A	1	00 - 7F	INSERTION EFFECT PARAMETER9	o	Refer to the XG EFFECT PARAMETER LIST	depends on insertion 1 type
0B	1	00 - 7F	INSERTION EFFECT PARAMETER10	o	Refer to the XG EFFECT PARAMETER LIST	depends on insertion 1 type
0C	1	00 - 7F	INSERTION EFFECT PART	x	Part1...16(0...15) AD1(64) OFF(16...63, 65...127)	7F
0D	1	00 - 7F	MW INSERTION CONTROL DEPTH	o	---	40
0E	1	00 - 7F	BEND INSERTION CONTROL DEPTH	o	---	40
0F	1	00 - 7F	CAT INSERTION CONTROL DEPTH	o	---	40
10	1	00 - 7F	AC1 INSERTION CONTROL DEPTH	x	---	40
11	1	00 - 7F	AC2 INSERTION CONTROL DEPTH	x	---	40
TOTAL SIZE		12				

04 00 14	1	00 - 7F	UNIQUE INSERTION EFFECT EXTERNAL CONTROL CH1(HARMONY CHANNEL*)	o	1...16(0...15), off(127)	7F
15	1	00 - 7F	UNIQUE INSERTION EFFECT EXTERNAL CONTROL CH2 (MELODY CHANNEL*)	o	1...16(0...15), off(127)	7F
TOTAL SIZE		2				

04 00 20	1	00 - 7F	INSERTION EFFECT PARAMETER11	o	Refer to the XG EFFECT PARAMETER LIST	depends on insertion 1 type
21	1	00 - 7F	INSERTION EFFECT PARAMETER12	o	Refer to the XG EFFECT PARAMETER LIST	depends on insertion 1 type
22	1	00 - 7F	INSERTION EFFECT PARAMETER13	o	Refer to the XG EFFECT PARAMETER LIST	depends on insertion 1 type
23	1	00 - 7F	INSERTION EFFECT PARAMETER14	o	Refer to the XG EFFECT PARAMETER LIST	depends on insertion 1 type
24	1	00 - 7F	INSERTION EFFECT PARAMETER15	o	Refer to the XG EFFECT PARAMETER LIST	depends on insertion 1 type
25	1	00 - 7F	INSERTION EFFECT PARAMETER16	o	Refer to the XG EFFECT PARAMETER LIST	depends on insertion 1 type
TOTAL SIZE		6				

*HARMONY CHANNEL and MELODY CHANNEL
About these settings, the last message is effective.
When the Melody channel is 3 and a message that set the Harmony Channel to 3 is received, the Melody channel is set to OFF and the Harmony channel is set to 3.

<Table 3-7> MIDI PARAMETER CHANGE TABLE (DISPLAY DATA)

Address	Size (H)	Data (H)	Parameter	Recognized	Description	Default
6 0 0 : 1F	20		(DISPLAY LETTER)	x	---	
TOTAL SIZE		20				

7 vh 0 : 2F	30		(DISPLAY BITMAP Data0) : (Data47)	x	---	
TOTAL SIZE		30				

<Table 3-8> MIDI PARAMETER CHANGE TABLE (MULTI PART)

Address (H)	Size (H)	Data (H)	Parameter	Recognized							Description	Default value(H)
				XG/GM	Keyboard	R1	R2	R3	Left	Acmp		
8 nn 0	1	00 - 20	ELEMENT RESERVE	o	x	x	x	x	x	x	0 - 32	part10=0, other =2
nn 1	1	00 - 7F	BANK SELECT MSB	o	x	o	o	o	o	o	0 - 127	part10=7F, other=0
nn 2	1	00 - 7F	BANK SELECT LSB								0 - 127	0
nn 3	1	00 - 7F	PROGRAM NUMBER	o	x	o	o	o	o	o	1 - 128	0
nn 4	1	00 - 0F, 7F	Rcv CHANNEL	o	x	x	x	x	x	x	1 - 16, OFF	Part No.
nn 5	1	00 - 01	MONO/POLY MODE	o	x	o	o	o	o	x	0:MONO 1:POLY	1

MIDI Data Format/MIDI-Datenformat/Format de données MIDI

nn 6	1	00 - 02	SAME NOTE NUMBER KEY ON ASSIGN	o	x	o	o	o	o	o	o	0:SINGLE 1:MULTI 2:INST (for DRUM)	1
nn 7	1	00 - 05	PART MODE	o	x	x	x	x	x	x	x	0:NORMAL 1:DRUM(ROM) 2 - 3:DRUMS1~ (RAM) 4-5:DRUM(ROM)	00 (Except Part10) 02 (Part10) 04,05 = [L3-80]
nn 8	1	28 - 58	NOTE SHIFT	o	x	o	o	o	o	o	o	-24 - +24[semitones]	40
nn 9	2	00 - FF	DETUNE	o	x	o	o	o	o	o	o	-12.8 - +12.7[Hz] 1st bit3-0→bit7-4 2nd bit3-0→bit3-0	08 00 (80)
nn 0B	1	00 - 7F	VOLUME	o	x	o	o	o	o	o	o	0 - 127	64
nn 0C	1	00 - 7F	VELOCITY SENSE DEPTH	o	x	o	o	o	o	o	o	0 - 127	40
nn 0D	1	00 - 7F	VELOCITY SENSE OFFSET	o	x	o	o	o	o	o	o	0 - 127	40
nn 0E	1	00 - 7F	PAN	o	x	o	o	o	o	o	o	0:random L63...C...R63(1...64...127)	40
nn 0F	1	00 - 7F	NOTE LIMIT LOW	o	x	o	o	o	o	o	o	C-2 - G8	0
nn 10	1	00 - 7F	NOTE LIMIT HIGH	o	x	o	o	o	o	o	o	C-2 - G8	7F
nn 11	1	00 - 7F	DRY LEVEL	o	x	o	o	o	o	o	o	0 - 127	7F
nn 12	1	00 - 7F	CHORUS SEND	o	x	o	o	o	o	o	o	0 - 127	0
nn 13	1	00 - 7F	REVERB SEND	o	x	o	o	o	o	o	o	0 - 127	28
nn 14	1	00 - 7F	VARIATION SEND	o	x	o	o	o	o	o	o	0 - 127	0
nn 15	1	00 - 7F	VIBRATO RATE	o	x	o	o	o	o	o	o	-64 - +63	40
nn 16	1	00 - 7F	VIBRATO DEPTH	o	x	o	o	o	o	o	o	-64 - +63	40
nn 17	1	00 - 7F	VIBRATO DELAY	o	x	o	o	o	o	o	o	-64 - +63	40
nn 18	1	00 - 7F	FILTER CUTOFF FREQUENCY	o	x	o	o	o	o	o	o	-64 - +63	40
nn 19	1	00 - 7F	FILTER RESONANCE	o	x	o	o	o	o	o	o	-64 - +63	40
nn 1A	1	00 - 7F	EG ATTACK TIME	o	x	o	o	o	o	o	o	-64 - +63	40
nn 1B	1	00 - 7F	EG DECAY TIME	o	x	o	o	o	o	o	o	-64 - +63	40
nn 1C	1	00 - 7F	EG RELEASE TIME	o	x	o	o	o	o	o	o	-64 - +63	40
nn 1D	1	28 - 58	MW PITCH CONTROL	o	x	o	o	o	o	o	o	-24 - +24[semitones]	40
nn 1E	1	00 - 7F	MW FILTER CONTROL	o	x	o	o	o	o	o	o	-9600 - +9450[cent]	40
nn 1F	1	00 - 7F	MW AMPLITUDE CONTROL	o	x	o	o	o	o	o	o	-100 - +100[%]	40
nn 20	1	00 - 7F	MW LFO PMOD DEPTH	o	x	o	o	o	o	o	o	0 - 127	0A
nn 21	1	00 - 7F	MW LFO FMOD DEPTH	o	x	o	o	o	o	o	o	0 - 127	0
nn 22	1	00 - 7F	MW LFO AMOD DEPTH	o	x	o	o	o	o	o	o	0 - 127	0
nn 23	1	28 - 58	BEND PITCH CONTROL	o	x	o	o	o	o	o	o	-24 - +24[semitones]	42
nn 24	1	00 - 7F	BEND FILTER CONTROL	o	x	o	o	o	o	o	o	-9600 - +9450[cent]	40
nn 25	1	00 - 7F	BEND AMPLITUDE CONTROL	o	x	o	o	o	o	o	o	-100 - +100[%]	40
nn 26	1	00 - 7F	BEND LFO PMOD DEPTH	o	x	o	o	o	o	o	o	0 - 127	0
nn 27	1	00 - 7F	BEND LFO FMOD DEPTH	o	x	o	o	o	o	o	o	0 - 127	0
nn 28	1	00 - 7F	BEND LFO AMOD DEPTH	o	x	o	o	o	o	o	o	0 - 127	0

TOTAL SIZE 29

Address (H)	Size (H)	Data (H)	Parameter	Recognized							Description	Default value(H)	
				XG/GM	Keyboard	R1	R2	R3	Left	Acmp			
nn 30	1		(Rcv PITCH BEND)	x	x	x	x	x	x	x	—		
nn 31	1		(Rcv CH AFTER TOUCH(CAT))	x	x	x	x	x	x	x	—		
nn 32	1		(Rcv PROGRAM CHANGE)	x	x	x	x	x	x	x	—		
nn 33	1		(Rcv CONTROL CHANGE)	x	x	x	x	x	x	x	—		
nn 34	1		(Rcv POLY AFTER TOUCH(PAT))	x	x	x	x	x	x	x	—		
nn 35	1		Rcv NOTE MESSAGE	o	x	x	x	x	x	x	OFF, ON	1	
nn 36	1		(Rcv RPN)	x	x	x	x	x	x	x	—		
nn 37	1		(Rcv NRPN)	x	x	x	x	x	x	x	—		
nn 38	1		(Rcv MODULATION)	x	x	x	x	x	x	x	—		
nn 39	1		(Rcv VOLUME)	x	x	x	x	x	x	x	—		
nn 3A	1		(Rcv PAN)	x	x	x	x	x	x	x	—		
nn 3B	1		(Rcv EXPRESSION)	x	x	x	x	x	x	x	—		
nn 3C	1		(Rcv HOLD1)	x	x	x	x	x	x	x	—		
nn 3D	1		(Rcv PORTAMENTO)	x	x	x	x	x	x	x	—		
nn 3E	1		(Rcv SOSTENUTO)	x	x	x	x	x	x	x	—		
nn 3F	1		(Rcv SOFT PEDAL)	x	x	x	x	x	x	x	—		
nn 40	1		(Rcv BANK SELECT)	x	x	x	x	x	x	x	—		
nn 41	1	00 - 7F	SCALE TUNING C	o	x	o	o	o	o	o	o	-64 - +63[cent]	40
nn 42	1	00 - 7F	SCALE TUNING C#	o	x	o	o	o	o	o	o	-64 - +63[cent]	40
nn 43	1	00 - 7F	SCALE TUNING D	o	x	o	o	o	o	o	o	-64 - +63[cent]	40
nn 44	1	00 - 7F	SCALE TUNING D#	o	x	o	o	o	o	o	o	-64 - +63[cent]	40
nn 45	1	00 - 7F	SCALE TUNING E	o	x	o	o	o	o	o	o	-64 - +63[cent]	40
nn 46	1	00 - 7F	SCALE TUNING F	o	x	o	o	o	o	o	o	-64 - +63[cent]	40
nn 47	1	00 - 7F	SCALE TUNING F#	o	x	o	o	o	o	o	o	-64 - +63[cent]	40
nn 48	1	00 - 7F	SCALE TUNING G	o	x	o	o	o	o	o	o	-64 - +63[cent]	40
nn 49	1	00 - 7F	SCALE TUNING G#	o	x	o	o	o	o	o	o	-64 - +63[cent]	40
nn 4A	1	00 - 7F	SCALE TUNING A	o	x	o	o	o	o	o	o	-64 - +63[cent]	40
nn 4B	1	00 - 7F	SCALE TUNING A#	o	x	o	o	o	o	o	o	-64 - +63[cent]	40
nn 4C	1	00 - 7F	SCALE TUNING B	o	x	o	o	o	o	o	o	-64 - +63[cent]	40

MIDI Data Format/MIDI-Datenformat/Format de données MIDI

nn 4D	1		CAT PITCH CONTROL	o	x	o	o	o	o	x	-24 - +24[semitones]	40
nn 4E	1		CAT FILTER CONTROL	o	x	o	o	o	o	x	-9600 - +9450[cent]	40
nn 4F	1		CAT AMPLITUDE CONTROL	o	x	o	o	o	o	x	-100 - +100[%]	40
nn 50	1		CAT LFO PMOD DEPTH	o	x	o	o	o	o	x	0 - 127	0
nn 51	1		CAT LFO FMOD DEPTH	o	x	o	o	o	o	x	0 - 127	0
nn 52	1		CAT LFO AMOD DEPTH	o	x	o	o	o	o	x	0 - 127	0
nn 53	1		PAT PITCH CONTROL	x	x	x	x	x	x	x	---	40
nn 54	1		PAT FILTER CONTROL	x	x	x	x	x	x	x	---	40
nn 55	1		PAT AMPLITUDE CONTROL	x	x	x	x	x	x	x	---	40
nn 56	1		PAT LFO PMOD DEPTH	x	x	x	x	x	x	x	---	0
nn 57	1		PAT LFO FMOD DEPTH	x	x	x	x	x	x	x	---	0
nn 58	1		PAT LFO AMOD DEPTH	x	x	x	x	x	x	x	---	0
nn 59	1		AC1 CONTROLLER NUMBER	x	x	x	x	x	x	x	---	10
nn 5A	1		AC1 PITCH CONTROL	x	x	x	x	x	x	x	---	40
nn 5B	1		AC1 FILTER CONTROL	x	x	x	x	x	x	x	---	40
nn 5C	1		AC1 AMPLITUDE CONTROL	x	x	x	x	x	x	x	---	40
nn 5D	1		AC1 LFO PMOD DEPTH	x	x	x	x	x	x	x	---	0
nn 5E	1		AC1 LFO FMOD DEPTH	x	x	x	x	x	x	x	---	0
nn 5F	1		AC1 LFO AMOD DEPTH	x	x	x	x	x	x	x	---	0
nn 60	1		AC2 CONTROLLER NUMBER	x	x	x	x	x	x	x	---	11
nn 61	1		AC2 PITCH CONTROL	x	x	x	x	x	x	x	---	40
nn 62	1		AC2 FILTER CONTROL	x	x	x	x	x	x	x	---	40
nn 63	1		AC2 AMPLITUDE CONTROL	x	x	x	x	x	x	x	---	40
nn 64	1		AC2 LFO PMOD DEPTH	x	x	x	x	x	x	x	---	0
nn 65	1		AC2 LFO FMOD DEPTH	x	x	x	x	x	x	x	---	0
nn 66	1		AC2 LFO AMOD DEPTH	x	x	x	x	x	x	x	---	0
nn 67	1		PORTAMENTO SWITCH	o	x	o	o	o	o	x	OFF/ON	0
nn 68	1		PORTAMENTO TIME	o	x	o	o	o	o	x	0 - 127	0
nn 69	1		PITCH EG INITIAL LEVEL	x	x	x	x	x	x	x	---	40
nn 6A	1		PITCH EG ATTACK TIME	x	x	x	x	x	x	x	---	40
nn 6B	1		PITCH EG RELEASE LEVEL	x	x	x	x	x	x	x	---	40
nn 6C	1		PITCH EG RELEASE TIME	x	x	x	x	x	x	x	---	40
nn 6D	1		VELOCITY LIMIT LOW	x	x	x	x	x	x	x	---	1
nn 6E	1		VELOCITY LIMIT HIGH	x	x	x	x	x	x	x	---	7F
TOTAL SIZE 3F												

<Table 3-8-2>

Address (H)	Size (H)	Data (H)	Parameter	Recognized							Description	Default value(H)
				XG/GM	Keyboard	R1	R2	R3	Left	Acomp		
08 nn 70	1		NOT USED	x	x	x	x	x	x	x	---	3E
nn 71	1		NOT USED	x	x	x	x	x	x	x	---	40
nn 72	1	00 - 7F	EQ BASS	o	x	o	o	o	o	o	-64 - +63(-12 - +12[dB])	40
nn 73	1	00 - 7F	EQ TREBLE	o	x	o	o	o	o	o	-64 - +63(-12 - +12[dB])	40
TOTAL SIZE 04												

<Table 3-8-3> XG ADDITIONAL PARAMETER CHANGE TABLE (MULTI PART)

Address (H)	Size (H)	Data (H)	Parameter	Recognized							Description	Default value(H)
				XG/GM	Keyboard	R1	R2	R3	Left	Acomp		
08 nn 74	1		NOT USED	x	x	x	x	x	x	x	---	40
75	1		NOT USED	x	x	x	x	x	x	x	---	40
76	1	04 - 28	EQ BASS frequency	o	x	o	o	o	o	o	32-2.0k[Hz]	0C
77	1	1C - 3A	EQ TREBLE frequency	o	x	o	o	o	o	o	500-16.0k[Hz]	36
78	1		NOT USED	x	x	x	x	x	x	x	---	22
79	1		NOT USED	x	x	x	x	x	x	x	---	2E
7A	1		NOT USED	x	x	x	x	x	x	x	---	7
7B	1		NOT USED	x	x	x	x	x	x	x	---	7
7C	1		NOT USED	x	x	x	x	x	x	x	---	7
7D	1		NOT USED	x	x	x	x	x	x	x	---	7
7E	1		NOT USED	x	x	x	x	x	x	x	---	0
7F	1		NOT USED	x	x	x	x	x	x	x	---	0
TOTAL SIZE 0C												

0A nn 10	1	00,08, 28-2D	OUTPUT SELECT	x	x	x	x	x	x	x	0:stereo out,8:indiv1+2 40:indiv1,41:indiv2,	0
TOTAL SIZE 1												

nn: PartNumber

If there is a Drum Voice assigned to the Part, the following parameters are ineffective.

- BANK SELECT LSB
- PORTAMENTO
- SOFT PEDAL
- MONO/POLY
- SCALE TUNING
- POLY AFTER TOUCH
- PITCH EG

<Table 3-9> MIDI PARAMETER CHANGE TABLE (A/D PART)

Address (H)	Size (H)	Data (H)	Parameter	Recognized	Description	Default value(H)
10 nn 0	1	00 - 01	INPUT GAIN	x	0:MIC,1:LINE	0
1	1	00 - 7F	BANK SELECT MSB	x	0 - 127	0
2	1	00 - 7F	BANK SELECT LSB	x	0 - 127	0
3	1	00 - 7F	PROGRAM NUMBER	x	1 - 128	0
4	1	00 - 1F, 7F	Rcv CHANNEL	o	A1 - A16,B1 - B16,OFF	7F
5	1		NOT USED			
6	1		NOT USED			
7	1		NOT USED			
8	1		NOT USED			
9	1		NOT USED			
0A	1		NOT USED			
0B	1	00 - 7F	VOLUME	o	0 - 127	0
0C	1		NOT USED			
0D	1		NOT USED			
0E	1	01 - 7F	PAN	o	L63...C...R63(1...64...127)	40
0F	1		NOT USED			
10	1		NOT USED			
11	1	00 - 7F	DRY LEVEL	o	0 - 127	7F
12	1	00 - 7F	CHORUS SEND	o	0 - 127	0
13	1	00 - 7F	REVERB SEND	o	0 - 127	0
14	1	00 - 7F	VARIATION SEND	o	0 - 127	0
TOTAL SIZE		15				

Address (H)	Size (H)	Data (H)	Parameter	Recognized	Description	Default value(H)
10 nn 30	1		NOT USED			
31	1		NOT USED			
32	1	00 - 01	Rcv PROGRAM CHANGE	x	—	1
33	1	00 - 01	Rcv CONTROL CHANGE	x	—	1
34	1		NOT USED			
35	1		NOT USED			
36	1		NOT USED			
37	1		NOT USED			
38	1		NOT USED			
39	1	00 - 01	Rcv VOLUME	x	—	1
3A	1	00 - 01	Rcv PAN	x	—	1
3B	1	00 - 01	Rcv EXPRESSION	x	—	1
3C	1		NOT USED			
3D	1		NOT USED			
3E	1		NOT USED			
3F	1		NOT USED			
40	1	00 - 01	Rcv BANK SELECT	x	—	1
41	1		NOT USED			
42	1		NOT USED			
43	1		NOT USED			
44	1		NOT USED			
45	1		NOT USED			
46	1		NOT USED			
47	1		NOT USED			
48	1		NOT USED			
49	1		NOT USED			
4A	1		NOT USED			
4B	1		NOT USED			
4C	1		NOT USED			
4D	1		NOT USED			
4E	1		NOT USED			
4F	1		NOT USED			
50	1		NOT USED			
51	1		NOT USED			
52	1		NOT USED			
53	1		NOT USED			
54	1		NOT USED			
55	1		NOT USED			
56	1		NOT USED			
57	1		NOT USED			
58	1		NOT USED			
59	1	00 - 5F	AC1 CONTROLLER NUMBER	x	—	10
5A	1		NOT USED			
5B	1		NOT USED			
5C	1		NOT USED			
5D	1		NOT USED			
5E	1		NOT USED			
5F	1		NOT USED			
60	1	00 - 5F	AC2 CONTROLLER NUMBER	x	—	11
TOTAL SIZE		31				

MIDI Data Format/MIDI-Datenformat/Format de données MIDI

11	00	nn	64	00-01	A/D SETUP	x	—		
TOTAL SIZE			64						

12	nn	10	1	00,08,28-2D	OUTPUT SELECT	x	0:stereo out,8:indiv1+2 40:indiv1,41:indiv2,	0
----	----	----	---	-------------	---------------	---	---	---

TOTAL SIZE 1
nn: A/D Part number(0 - 63)

<Table 3-10> MIDI PARAMETER CHANGE TABLE (DRUM SETUP)

Address (H)	Size (H)	Data (H)	Parameter	Recognized	Description	Default	
3n rr 0	1	00 - 7F	PITCH COARSE	o	-64 - +63	40	
3n rr 1	1	00 - 7F	PITCH FINE	o	-64 - +63[cent]	40	
3n rr 2	1	00 - 7F	LEVEL	o	0 - 127	depend on the note	
3n rr 3	1	00 - 7F	ALTERNATE GROUP	o	0:OFF 1 - 127	depend on the note	
3n rr 4	1	00 - 7F	PAN	o	0:random 1:L63 : 64:C(center) : 127:R63	depend on the note	
3n rr 5	1	00 - 7F	REVERB SEND	o	0 - 127	depend on the note	
3n rr 6	1	00 - 7F	CHORUS SEND	o	0 - 127	depend on the note	
3n rr 7	1	00 - 7F	VARIATION SEND	o	0 - 127	7F	
3n rr 8	1	00 - 01	KEY ASSIGN	o	0:SINGLE 1:MULTI	0	
3n rr 9	1	00 - 01	Rcv NOTE OFF	o	OFF/ON	depend on the note	
3n rr 0A	1	00 - 01	Rcv NOTE ON	o	OFF/ON	1	
3n rr 0B	1	00 - 7F	FILTER CUTOFF FREQUENCY	o	-64 - +63	40	
3n rr 0C	1	00 - 7F	FILTER RESONANCE	o	-64 - +63	40	
3n rr 0D	1	00 - 7F	EG ATTACK	o	-64 - +63	40	
3n rr 0E	1	00 - 7F	EG DECAY1	o	-64 - +63	40	
3n rr 0F	1	00 - 7F	EG DECAY2	o	-64 - +63	40	
TOTAL SIZE			10				

<Table 3-10-2> XG ADDITIONAL PARAMETER CHANGE TABLE (DRUM SETUP)

Address (H)	Size (H)	Data (H)	Parameter	Recognized	Description	Default	
3n rr 20	1	00 - 7F	EQ BASS	x		40	
21	1	00 - 7F	EQ TREBLE	x		40	
22	1		NOT USED	x	—	40	
23	1		NOT USED	x	—	40	
24	1	04 - 28	EQ BASS frequency	x		0C	
25	1	1C - 3A	EQ TREBLE frequency	x		36	
26	1		NOT USED	x	—	22	
27	1		NOT USED	x	—	2E	
28	1		NOT USED	x	—	7	
29	1		NOT USED	x	—	7	
2A	1		NOT USED	x	—	7	
2B	1		NOT USED	x	—	7	
2C	1		NOT USED	x	—	0	
2D	1		NOT USED	x	—	0	
TOTAL SIZE			0E				

3n rr 40	1	00,08,28-2D	OUTPUT SELECT	x	0:stereo out,8:indiv1+2 40:indiv1,41:indiv2,	0
----------	---	-------------	---------------	---	---	---

TOTAL SIZE 1

n: Drum Setup Number(0 - 1)
rr: note number(0DH - 5BH)

If XG SYSTEM ON and/or GM On message is received, all Drum Setup Parameter will be reset to default values.
According to the Drum Setup Reset message, individual Drum Setup Parameters can be reset to default values.
According to the Program Change for Drum Kit, Drum Setup Parameters can be reset to default values.

<Table 3-11> MIDI Parameter Change table (PLUGIN BOARD) [XG]

Address (H)	Size (H)	Data (H)	Parameter	Recognized	Description	Default	
70	tt nn	00 - 0F, 7F	Part Assign		Part1 ...16,OFF	00	
TOTAL SIZE			1				

71	tt mm	1	00 - 0F	Note Filter	Part1 ...16	--	
TOTAL SIZE			1				

tt: Board type (00:PLG100-VL, 02:PLG100-DX ...)
nn: Serial Number
mm: part number (00 - 0F)
These are recognized when the corresponding board is installed.

Functions of the MIDI B Port when Connected to the MFC10/ Funktionen des MIDI B Ports bei Verbindung mit dem MFC10/ Fonctions du port MIDI B lors de la connexion au MFC10

The MIDI B port can also be used for operation with the MFC10 MIDI Foot Controller.

<Table 1> MIDI B IN

MIDI Events	Status byte		1st Data byte		2nd Data byte		MFC10 channel number		Remarks
	Status		Data (HEX)	Parameter	Data (HEX)	Parameter	When n matches the MFC10's channel number.	When n does not match the MFC10's channel number.	
Key Off	8nH	(n:channel no.)	kk	Key no. (0~127)	vv	Velocity(0~127)	Handled as a message for control by the MFC10.	Handled as a normal Channel/Mode/Realtime message.	
Key On	9nH		kk	Key no. (0~127)	vv	Key On :vv=1~127 Key Off :vv=0	Handled as a message for control by the MFC10.	Handled as a normal Channel/Mode/Realtime message.	
Control Change	BnH		0 (00H)	Bank Select MSB	0 (00H) 126 (7EH) 127 (7FH)	Normal SFX kit Drum	Handled as a message for control by the MFC10.	Handled as a normal Channel/Mode/Realtime message.	
			1 (01H)	Modulation	0~127 (...7FH)		Handled as a message for control by the MFC10.	Handled as a normal Channel/Mode/Realtime message.	
			2 (02H)	No Assign	0~127 (...7FH)		Handled as a message for control by the MFC10.	Handled as a normal Channel/Mode/Realtime message.	
			3 (03H)	No Assign	0~127 (...7FH)		Handled as a message for control by the MFC10.	Handled as a normal Channel/Mode/Realtime message.	
			4 (04H)	Foot Control	0~127 (...7FH)		Handled as a message for control by the MFC10.	Handled as a normal Channel/Mode/Realtime message.	
			7 (07H)	Main Volume	0~127 (...7FH)		Handled as a message for control by the MFC10.	Handled as a normal Channel/Mode/Realtime message.	
			Other	-	-		-	Handled as a normal Channel/Mode/Realtime message.	
RealTime Message	F8H	MIDI Clock	-		-		Handled as a normal Channel/Mode/Realtime message.	Handled as a normal Channel/Mode/Realtime message.	
	FEH	Active Sens	-		-		Handled as a normal Channel/Mode/Realtime message.	Handled as a normal Channel/Mode/Realtime message.	
Other	Other		-	-	-	-	Handled as a normal Channel/Mode/Realtime message.		

<Table 2> MIDI B OUT

MIDI Events	Status byte		1st Data byte		2nd Data byte		Transmit	Remarks	
	Status		Data (HEX)	Parameter	Data (HEX)	Parameter			
RealTime Message	FEH	Active Sens	-		-		o	Transmits every 200msec.	
SYSTEM EXCLUSIVE MESSAGE	MFC10 Bulk Dump							o	Transmits after checking the connection with the MFC10 and changing the MFC10's channel number.
Other			-	-	-		x		

MIDI Implementation Chart/MIDI-Implementierungstabelle/

YAMAHA [Professional Workstation]
 Model 9000Pro MIDI Implementation Chart

Date:9-SEP-1999
 Version : 1.0

Function...	Transmitted	Recognized	Remarks
Basic Default	1 - 16 *1	1 - 16 *2	
Channel Changed	1 - 16 *1	1 - 16 *2	
Mode Default	3	3	
Messages	x	x	
Altered	*****	x	
Note Number : True voice	0 - 127 *****	0 - 127 0 - 127	
Velocity Note ON	o 9nH,v=1-127	o 9nH,v=1-127	
Note OFF	x 9nH,v=0	x	
After Key's	x	x	
Touch Ch's	o	o	
Pitch Bend	o	o 0-24 semi	
Control Change	0,32 o 1,5,7,10,11 o 6,38 o 64-67 o 71,74 o 72,73 x *3 84 x *3 91,93,94 o 96,97 x 98,99 o 100,101 o	o *1 o *1 o *1 o *1 o *1 o *1 o *1 o *1 o *1 o *1	Bank Select Data Entry Sound Controller Sound Controller Portamento Cntrl Effect Depth Data Inc,Dec NRPN LSB,MSB RPN LSB,MSB
Prog Change : True #	o 0 - 127 *****	o 0 - 127	
System Exclusive	o	o	
: Song Pos.	x	x	
Common : Song Sel.	x	x	
: Tune	x	x	
System : Clock	o	o	
Real Time: Commands	o	o	
Aux :All Sound OFF	x	o(120,126,127)	
:Reset All Cntrls	x	o(121)	
:Local ON/OFF	x	x	
:All Notes OFF	x	o(123-125)	
Mes- :Active Sense	o	o	
sages:Reset	x	x	
Notes: *1,*2,*3 see next page.			

Mode 1 : OMNI ON , POLY Mode 2 : OMNI ON , MONO o : Yes
 Mode 3 : OMNI OFF, POLY Mode 4 : OMNI OFF, MONO x : No

Feuille d'implémentation MIDI

- *1 The tracks for each channel can be selected on the panel. See page 175 for more information.
- *2 The tone generator normally functions as a 16-channel multi-timbre tone generator in response to MIDI input. MIDI messages therefore do not normally affect the panel voices or other panel settings. The MIDI messages listed below, however, do affect the panel voice, style, Multi Pad, and song settings.
- MIDI MASTER TUNE, XG System parameter MASTER TUNE
 - XG System parameter TRANSPOSE
 - System exclusive messages which change the REVERB, CHORUS or DSP EFFECT settings.
 - XG MULTI EQ parameters
- Also, the MIDI messages affect the panel settings when one of the following MIDI reception modes is selected. These modes can be selected on the panel (see page 176).
- RIGHT1, RIGHT2, RIGHT3, LEFT, KEYBOARD, ACMP RHYTHM1, ACMP RHYTHM2, ACMP BASS, ACMP CHORD1, ACMP CHORD2, ACMP PAD, ACMP PHRASE1, ACMP PHRASE2
 - CHORD
 - ROOT
 - OFF
- *3 These Control Change Messages are not transmitted by 9000Pro panel operation, but may be transmitted by the ACCOMPANIMENT or SONG playing.

- *1 Die Tracks können für jeden Channel auf dem Panel eingestellt werden. Weitere Informationen finden Sie auf Seite 175.
- *2 Der Ton-Generator funktioniert normalerweise in Antwort auf MIDI-Input als Multi-Timbre-Ton-Generator mit 16 Channels. MIDI-Nachrichten haben demnach keinen Einfluß auf die Panel-Voices oder andere Panel-Einstellungen. Die unten aufgeführten MID-Meldungen wirken sich jedoch auf Frontplatten-Voices, Style-, Multi Pad- und Songeinstellungen aus.
- MIDI MASTER TUNE, XG System-Parameter MASTER TUNE
 - XG System-Parameter TRANSPOSE
 - System Exclusive-Nachrichten, welche die Einstellungen REVERB, CHORUS oder DSP EFFECT ändern.
 - XG MULTI EQ-Parameter
- MIDI-Nachrichten haben auch Einfluß auf die Panel-Einstellungen, wenn einer der folgenden MIDI-Empfangsmodi gewählt ist. Diese Modi können auf der Frontplatte ausgewählt werden (siehe Seite 176).
- RIGHT1, RIGHT2, RIGHT3, LEFT, KEYBOARD, ACMP RHYTHM1, ACMP RHYTHM2, ACMP BASS, ACMP CHORD1, ACMP CHORD2, ACMP PAD, ACMP PHRASE1, ACMP PHRASE2
 - CHORD
 - ROOT
 - OFF
- *3 Diese Control Change-Nachrichten werden nicht durch die Panel-Bedienung des 9000Pro übermittelt, sondern können durch die ACCOMPANIMENT (Begleitung) oder die SONG-Wiedergabe übermittelt werden.

- *1 Les pistes de chaque canal peuvent être sélectionnées sur le panneau. Pour plus d'informations, voir page 175.
- *2 Le générateur de son fonctionne normalement comme un générateur de son multi-timbre à 16 canaux en réponse à une entrée MIDI. Par conséquent, les messages MIDI n'affectent généralement pas les voix de panneau ou les autres réglages de panneau. Toutefois, les messages MIDI listés ci-dessous affectent les réglages de la voix du tableau, du style, des multitouches, des morceaux.
- MIDI MASTER TUNE, paramètres du système XG MASTER TUNE
 - Paramètres du système XG TRANSPOSE
 - Messages exclusifs au système qui modifient les réglages REVERB, CHORUS ou EFFET DSP.
 - Paramètres XG MULTI EQ
- De plus, les messages MIDI affectent les réglages du panneau lorsque l'un des modes de réception MIDI suivants est sélectionné. Ces modes peuvent être sélectionnés sur le tableau (voir page 176).
- RIGHT1, RIGHT2, RIGHT3, LEFT, KEYBOARD, ACMP RHYTHM1, ACMP RHYTHM2, ACMP BASS, ACMP CHORD1, ACMP CHORD2, ACMP PAD, ACMP PHRASE1, ACMP PHRASE2
 - CHORD
 - ROOT
 - OFF
- *3 Ces messages de modification de commandes ne sont pas transmis par l'opération du panneau du 9000Pro, mais peuvent être transmis par la reproduction ACCOMPANIMENT (Accompagnement) ou SONG (Morceau).

Specifications/Technische Daten/Spécifications

Keyboard:	76 Keys (E0 ~ G6) Weighted	with Touch Response (Initial/After)
Polyphony:	126 Notes max	
Voices:		
Preset	848	342 Voices + 480 XG Voices + 24 Drum Kits + 2 SFX Kits
Custom	32	User programmable
Organ Flute	20	10 Preset + 10 User, 9 Footages; with Modeling Technology
Orchestration:		
Right	3 PART	RIGHT1, RIGHT2, RIGHT3
Left	1 PART	
Plug-In System:		
Slots	2	
Supported Boards	PLG100-DX, PLG100-VL, PLG150-AN, PLG150-PF, PLG150-DX, PLG150-VL, PLG100-XG	
Edit	Plug-in Custom Voice Creator	
Sampling:		
Quality	16bit 44.1KHz	
File Import	AIFF, WAV	
Edit	Resampling/Loop Point/Normalize/Volume/Tune	
RAM Capacity	1MByte	11.8sec
Expanded Capacity	9M/17M/33M/65MByte	106.9/202.1/392.3/772.7sec
Consecutive Record Time	380sec max	When 2 SIMM modules (16MB or 32MB) are installed..
Effects:		
Reverb	29 Preset + 3 User	
Chorus	25 Preset + 3 User	
DSP Effect	164 Preset	for Style and Song
DSP Effect	(164 Preset + 10 User) x 4 Blocks	for R1, R2, R3, LEFT
Number of Effects in DSP	Max. 3	
DSP Effect	84 Preset + 10 User	for Mic/Line In
DSP Variation	Slow/Fast	for R1, R2, R3, LEFT
POLY/MONO	Yes	
Vocal Harmony	59 Preset + 10 User	3 notes polyphony
Harmony/Echo	17 Preset	
Master EQ	2 Preset + 2 User	5 Band
Part EQ	29 Part	2 Band, 29 Part (R1, R2, R3, LEFT, ACOMPx8, SONGx16, M.PAD)
Touch Response	5 Preset	
Tempo	32 ~ 280	
Transpose	-24 ~ 0 ~ 24	
Tuning	414.6 ~ 440 ~ 466.8Hz	
Octave	-1, 0, +1	only for Upper
Pitch Bend	Wheel	
Modulation	Wheel	
Left Hold	Yes	
Auto Accompaniment:		
Preset	125	
Flash	87	Up to 1.8MByte, 120 style max.
Disk	66 (included in the accessory disk)	DISK DIRECT function is available.
Custom Style	1	Pattern Assembly, Realtime/Step Rec, Event Edit, Full Parameter Edit
Format	Style File Format	
Control	INTRO x 3 FILL IN x 4 BREAK FILL x 1 MAIN x 4 ENDING x 3 FADE IN/OUT TAP TEMPO	
Fingering	Single Finger, Multi Finger, Fingered, Fingered Pro, On Bass, On Bass Pro, Full Keyboard	
One Touch Setting:	4/Style	Fully programmable
Music Database:	616	Fully programmable
Multi Pad:	4Pads x 60 Banks	58 Multi Pad Bank, 1 MIDI Control Bank, 1 Scale Tune Bank Realtime/Step Rec, Event Edit
Song:		
Playback	Disk Direct Playback	with Ultra Quick Start function
Track	16	
Recording	RAM Recording	Quick/Multitrack/Step/Chord Step Rec, Event Edit
RAM Capacity	300kbyte	Approximately 38,000 notes max.

Registration Memeory:

512 8 Switches x 64 Banks, Freeze function

Language:

5 languages English, German, French, Spanish, Italian

Display:

Back Lit Graphic LCD 240 x 320 Dots, video out capability

Disk:

Floppy Disk Drive 3.5" 2HD/2DD
Built-in Hard Disk Optional

Demonstations:

18 songs

Connectors:

MIDI	MIDI A/B (IN/OUT) TO HOST	MIDI A can switch to TO HOST. HOST SELECT SW (Mac/PC1/PC2/MIDI)
Foot Pedal	FOOT SWITCH1 FOOT SWITCH2 FOOT VOLUME	
SCSI	D-sub Half Pitch 50pins	
VIDEO OUT	Pin Type	NTSC/PAL Composite Signal
PC KEYBOARD	Mini DIN Type	PC/AT Standard
Console Lamp Socket	2	for gooseneck lamp
Analog	PHONES LOOP SEND(L/L+R,R) LINE OUT MAIN (L/L+R,R), SUB (1/2/3/4) AUX IN/LOOP RETURN(L/L+R,R), TRIM VOL MIC/LINE IN (XLR/PHONE Plug Compatible)	LEVEL (MIC1/MIC2/LINE), INPUT VOLUME, Indicator

Power Consumption:

47W (120V), 47W (220 ~ 240V)

Weight:

20.5Kg (45lbs. 3oz)

Dimensions:

W x H x D 1269 x 407.5 x 140mm without Music Stand
(49-15/16" x 16-1/16" x 5-1/2")

Supplied Accessories:

Music Stand	1	
AC Power Cord	1	
AC Plug Adaptor	1	in applicable areas only
Floppy Disk	4	Disk Styles, Factory Data Backup Disk, Plug-in Custom Voice Disk
Owner's Manual	1	

Optional Accessories:

Foot Switch	FC5	
Foot Volume	FC7	
Headphones	HPE-150,160	
Mic	MZ106s	Dynamic Microphone IMP.250Ω
Keyboard Stand	LG-100	
Hard Disk	2.5inch IDE	Height 12.5mm max, 8GByte max
SIMM	4M/8M/16M/32MByte	72pin SIMM, 16bit BUS, JEDEC
SCSI Device	SCSI-2	Hard Disk, CD-ROM*, ZIP, MO, Jaz (Iomega), 8GByte max per device
PC Keyboard	PC/AT Standard	
CRT Display	NTSC or PAL	
Gooseneck Lamp	4 Pin XLR Connector	DC 12V / 5 W max.

* Supports ISO9660 Level1 except Multi Session Disk Format.
Audio-CD Format is not supported.

- Specifications and descriptions in this owner's manual are for information purposes only. Yamaha Corp. reserves the right to change or modify products or specifications at any time without prior notice. Since specifications, equipment or options may not be the same in every locale, please check with your Yamaha dealer.
- Die technischen Daten und Beschreibungen in dieser Bedienungsanleitung dienen nur der Information. Yamaha Corp. behält sich das Recht vor, Produkte oder deren technische Daten jederzeit ohne vorherige Ankündigung zu verändern oder zu modifizieren. Da die technischen Daten, das Gerät selbst oder Sonderzubehör nicht in jedem Land gleich sind, setzen Sie sich im Zweifel bitte mit Ihrem Yamaha-Händler in Verbindung.
- Les caractéristiques techniques et les descriptions du mode d'emploi ne sont données que pour information. Yamaha Corp. se réserve le droit de changer ou modifier les produits et leurs caractéristiques techniques à tout moment sans aucun avis. Du fait que les caractéristiques techniques, les équipements et les options peuvent différer d'un pays à l'autre, adressez-vous au distributeur Yamaha le plus proche.

FCC INFORMATION (U.S.A.)

1. IMPORTANT NOTICE: DO NOT MODIFY THIS UNIT!

This product, when installed as indicated in the instructions contained in this manual, meets FCC requirements. Modifications not expressly approved by Yamaha may void your authority, granted by the FCC, to use the product.

2. IMPORTANT:

When connecting this product to accessories and/or another product use only high quality shielded cables. Cable/s supplied with this product MUST be used. Follow all installation instructions. Failure to follow instructions could void your FCC authorization to use this product in the USA.

3. NOTE:

This product has been tested and found to comply with the requirements listed in FCC Regulations, Part 15 for Class "B" digital devices. Compliance with these requirements provides a reasonable level of assurance that your use of this product in a residential environment will not result in harmful interference with other electronic devices. This equipment generates/uses radio frequencies and, if not installed and used according to the instructions found in the users manual, may cause interference harmful to the operation of other electronic devices. Compliance with FCC regulations does not

guarantee that interference will not occur in all installations. If this product is found to be the source of interference, which can be determined by turning the unit "OFF" and "ON", please try to eliminate the problem by using one of the following measures:

Relocate either this product or the device that is being affected by the interference.

Utilize power outlets that are on different branch (circuit breaker or fuse) circuits or install AC line filter/s.

In the case of radio or TV interference, relocate/reorient the antenna. If the antenna lead-in is 300 ohm ribbon lead, change the lead-in to co-axial type cable.

If these corrective measures do not produce satisfactory results, please contact the local retailer authorized to distribute this type of product. If you can not locate the appropriate retailer, please contact Yamaha Corporation of America, Electronic Service Division, 6600 Orangethorpe Ave, Buena Park, CA90620

The above statements apply ONLY to those products distributed by Yamaha Corporation of America or its subsidiaries.

* This applies only to products distributed by YAMAHA CORPORATION OF AMERICA.

(class B)

The serial number of this product may be found on the rear of the unit. You should note this serial number in the space provided below and retain this manual as a permanent record of your purchase to aid identification in the event of theft.

Model No.

Serial No.

(rear)

IMPORTANT NOTICE FOR THE UNITED KINGDOM

Connecting the Plug and Cord

WARNING: THIS APPARATUS MUST BE EARTHED

IMPORTANT. The wires in this mains lead are coloured in accordance with the following code:

GREEN-AND-YELLOW: EARTH

BLUE : NEUTRAL

BROWN : LIVE

As the colours of the wires in the mains lead of this apparatus may not correspond with the coloured markings identifying the terminals in your plug proceed as follows:

The wire which is coloured GREEN-and-YELLOW must be connected to the terminal in the plug which is marked by the letter E or by the safety earth symbol or colored GREEN or GREEN-and-YELLOW.

The wire which is coloured BLUE must be connected to the terminal which is marked with the letter N or coloured BLACK.

The wire which is coloured BROWN must be connected to the terminal which is marked with the letter L or coloured RED.

(3 wires)

• This applies only to products distributed by Yamaha-Kemble Music (U.K.) Ltd.

For details of products, please contact your nearest Yamaha or the authorized distributor listed below.

Pour plus de détails sur les produits, veuillez-vous adresser à Yamaha ou au distributeur le plus proche de vous figurant dans la liste suivante.

Die Einzelheiten zu Produkten sind bei Ihrer unten aufgeführten Niederlassung und bei Yamaha Vertragshändlern in den jeweiligen Bestimmungsländern erhältlich.

Para detalles sobre productos, contacte su tienda Yamaha más cercana o el distribuidor autorizado que se lista debajo.

NORTH AMERICA

CANADA

Yamaha Canada Music Ltd.
135 Milner Avenue, Scarborough, Ontario,
M1S 3R1, Canada
Tel: 416-298-1311

U.S.A.

Yamaha Corporation of America
6600 Orangethorpe Ave., Buena Park, Calif. 90620,
U.S.A.
Tel: 714-522-9011

CENTRAL & SOUTH AMERICA

MEXICO

**Yamaha de Mexico S.A. De C.V.,
Departamento de ventas**
Javier Rojo Gomez No.1149, Col. Gpe Del
Moral, Deleg. Iztapalapa, 09300 Mexico, D.F.
Tel: 686-00-33

BRAZIL

Yamaha Musical do Brasil LTDA.
Av. Rebouças 2636, São Paulo, Brasil
Tel: 011-853-1377

ARGENTINA

Yamaha Music Argentina S.A.
Viamonte 1145 Piso2-B 1053,
Buenos Aires, Argentina
Tel: 1-371-7021

PANAMA AND OTHER LATIN AMERICAN COUNTRIES/ CARIBBEAN COUNTRIES

Yamaha de Panama S.A.
Torre Banco General, Piso 7, Urbanización Marbella,
Calle 47 y Aquilino de la Guardia,
Ciudad de Panamá, Panamá
Tel: 507-269-5311

EUROPE

THE UNITED KINGDOM

Yamaha-Kemble Music (U.K.) Ltd.
Sherbourne Drive, Tilbrook, Milton Keynes,
MK7 8BL, England
Tel: 01908-366700

IRELAND

Danfay Ltd.
61D, Sallynoggin Road, Dun Laoghaire, Co. Dublin
Tel: 01-2859177

GERMANY/SWITZERLAND

Yamaha Europa GmbH.
Siemensstraße 22-34, 25462 Rellingen,
F.R. of Germany
Tel: 04101-3030

AUSTRIA

Yamaha Music Austria
Schleiergasse 20, A-1100 Wien Austria
Tel: 01-60203900

THE NETHERLANDS

Yamaha Music Nederland
Kanaalweg 18G, 3526KL, Utrecht, The Netherlands
Tel: 030-2828411

BELGIUM

Yamaha Music Belgium
Keiberg Imperiastraat 8, 1930 Zaventem, Belgium
Tel: 02-7258220

FRANCE

**Yamaha Musique France,
Division Claviers**
BP 70-77312 Marne-la-Vallée Cedex 2, France
Tel: 01-64-61-4000

ITALY

**Yamaha Musica Italia S.P.A.,
Home Keyboard Division**
Viale Italia 88, 20020 Lainate (Milano), Italy
Tel: 02-935-771

SPAIN/PORTUGAL

Yamaha-Hazen Electronica Musical, S.A.
Ctra. de la Coruna km. 17, 200, 28230
Las Rozas (Madrid) Spain
Tel: 91-201-0700

GREECE

Philippe Nakas S.A.
Navarinou Street 13, P.Code 10680, Athens, Greece
Tel: 01-364-7111

SWEDEN

Yamaha Scandinavia AB
J. A. Wettergrens Gata 1
Box 30053
S-400 43 Göteborg, Sweden
Tel: 031 89 34 00

DENMARK

YS Copenhagen Liaison Office
Generatorvej 8B
DK-2730 Herlev, Denmark
Tel: 44 92 49 00

FINLAND

F-Musiikki Oy
Kluuvikatu 6, P.O. Box 260,
SF-00101 Helsinki, Finland
Tel: 09 618511

NORWAY

Norsk filial av Yamaha Scandinavia AB
Grini Næringspark 1
N-1345 Østerås, Norway
Tel: 67 16 77 70

ICELAND

Skifan HF
Skeifan 17 P.O. Box 8120
IS-128 Reykjavik, Iceland
Tel: 525 5000

OTHER EUROPEAN COUNTRIES

Yamaha Europa GmbH.
Siemensstraße 22-34, 25462 Rellingen,
F.R. of Germany
Tel: 04101-3030

AFRICA

**Yamaha Corporation,
International Marketing Division**
Nakazawa-cho 10-1, Hamamatsu, Japan 430-8650
Tel: 053-460-2312

MIDDLE EAST

TURKEY/CYPRUS

Yamaha Europa GmbH.
Siemensstraße 22-34, 25462 Rellingen,
F.R. of Germany
Tel: 04101-3030

OTHER COUNTRIES

Yamaha Music Gulf FZE
LB21-128 Jebel Ali Freezone
P.O.Box 17328, Dubai, U.A.E.
Tel: 971-4-81-5868

ASIA

HONG KONG

Tom Lee Music Co., Ltd.
11/F., Silvercord Tower 1, 30 Canton Road,
Tsimshatsui, Kowloon, Hong Kong
Tel: 2737-7688

INDONESIA

**PT. Yamaha Music Indonesia (Distributor)
PT. Nusantik**
Gedung Yamaha Music Center, Jalan Jend. Gatot
Subroto Kav. 4, Jakarta 12930, Indonesia
Tel: 21-520-2577

KOREA

Cosmos Corporation
1461-9, Seocho Dong, Seocho Gu, Seoul, Korea
Tel: 02-3486-0011

MALAYSIA

Yamaha Music Malaysia, Sdn., Bhd.
Lot 8, Jalan Perbandaran, 47301 Kelana Jaya,
Petaling Jaya, Selangor, Malaysia
Tel: 3-703-0900

PHILIPPINES

Yupangco Music Corporation
339 Gil J. Puyat Avenue, P.O. Box 885 MCPO,
Makati, Metro Manila, Philippines
Tel: 819-7551

SINGAPORE

Yamaha Music Asia Pte., Ltd.
11 Ubi Road #06-00, Meiban Industrial Building,
Singapore
Tel: 65-747-4374

TAIWAN

Yamaha KHS Music Co., Ltd.
10F, 150, Tun-Hwa Northroad,
Taipei, Taiwan, R.O.C.
Tel: 02-2713-8999

THAILAND

Siam Music Yamaha Co., Ltd.
121/60-61 RS Tower 17th Floor,
Ratchadaphisek RD., Dindaeng,
Bangkok 10320, Thailand
Tel: 02-641-2951

THE PEOPLE'S REPUBLIC OF CHINA AND OTHER ASIAN COUNTRIES

**Yamaha Corporation,
International Marketing Division**
Nakazawa-cho 10-1, Hamamatsu, Japan 430-8650
Tel: 053-460-2317

OCEANIA

AUSTRALIA

Yamaha Music Australia Pty. Ltd.
17-33 Market Street, South Melbourne, Vic. 3205,
Australia
Tel: 3-699-2388

NEW ZEALAND

Music Houses of N.Z. Ltd.
146/148 Captain Springs Road, Te Papapa,
Auckland, New Zealand
Tel: 9-634-0099

COUNTRIES AND TRUST TERRITORIES IN PACIFIC OCEAN

**Yamaha Corporation,
International Marketing Group**
Nakazawa-cho 10-1, Hamamatsu, Japan 430-8650
Tel: 053-460-2312

HEAD OFFICE Yamaha Corporation, Pro Audio & Digital Musical Instrument Division
Nakazawa-cho 10-1, Hamamatsu, Japan 430-8650
Tel: 053-460-3273



Yamaha PK CLUB (Portable Keyboard Home Page)
<http://www.yamaha.co.jp/english/product/pk>
Yamaha Manual Library (English versions only)
<http://www2.yamaha.co.jp/manual/english/>

**This document is printed on chlorine free (ECF) paper with soy ink.
Auf Umweltpapier mit Sojatinte gedruckt.
Ce document a été imprimé sur du papier non blanchi au chlore
avec de l'encre d'huile de soja.**

M.D.G., Pro Audio & Digital Musical Instrument Division, Yamaha Corporation
© 2000 Yamaha Corporation

V619160 009POCP1.3-01A0 Printed in Japan